

# Model 1800 PFM Series Regulator

## Technical Bulletin



The 1800 PFM Series regulators are designed to control natural gas, air, nitrogen, carbon dioxide, propane vapor, and other non-corrosive gases in applications requiring precise outlet pressure control, medium-to-high capacity, and fast response to changing loads.

### General Information

Outlet pressures between 1 PSIG and 30 PSIG are available.

Operating temperature range is -20°F to 150°F (-30°C to 65°C).

Maximum flow rate is 60,000 SCFH (1,700 m<sup>3</sup>/h).

### Features

- Variety of interchangeable orifices and spring ranges.
- Either 1-1/2" or 2" threaded body or 2" flanged body.
- Maintain a constant outlet pressure within +/-1% absolute set pressure over a wide range of flow rates. Ideal for fixed factor measurement.

### Options

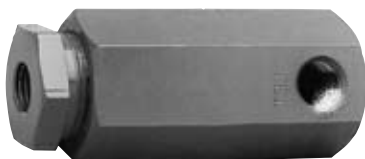

#### Pilot Filter

A 1/4" filter (Part Number 73407G001) containing a 5 micron element for the inlet gas to the pilot.

#### Limited Relief or No Relief

The pilot can have a limited relief or no relief.

#### Safety Shutoff Devices

- **Overpressure Shutoff (OPSO) —** The Overpressure Shutoff (OPSO) operates independently from the regulator, shutting off the gas supply in the event of extreme downstream pressure build-up. The recommended shutoff spring range should be a minimum differential of 1 PSIG between the normal operating pressure and the shutoff pressure set point.

### Applications

Model Number	Description
1803 PFM	Standard regulator.
1803M PFM	Standard regulator with external sense.
1883 PFM	Standard regulator with overpressure shutoff.
1883M PFM	Standard regulator with external sense and overpressure shutoff.
1883 PFM w/USSA	Standard regulator with overpressure shutoff.
1883M PFM w/USSA	Standard regulator with external sense and overpressure shutoff.

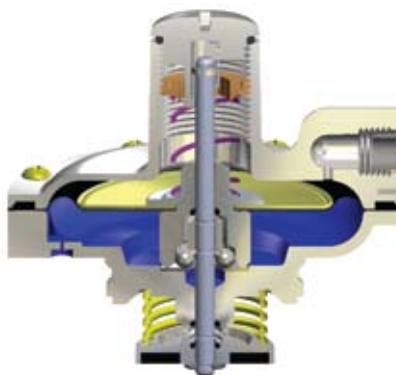

OPSO in cocked position

#### Over Pressure Shutoff Assemblies\*

Range	Assembly Number	
	Internal Sense	External Sense
1 to 2 PSI	72986G030	72986G086
2 – 3 PSI	72986G031	72986G087
3 – 5 PSI	72986G032	72986G088
5 – 8 PSI	72986G033	72986G089
8 – 14 PSI	72986G034	72986G090
14 – 20 PSI	72986G035	72986G091
20 – 35 PSI	72986G235	N/A

\* Other configurations are available. External sense connection is 1/8" NPT or 1/8" BSP threads.

- **Universal Safety Shutoff Assembly (USSA) —** The Universal Safety Shutoff Assembly (USSA) protects the downstream piping from overpressure conditions by shutting off the gas flow at the inlet side of the regulator orifice should an unusual operating condition occur.

Overpressure shutoff set points are adjustable depending on spring range selected:

#### USSA Shutoff Spring Ranges

Spring Range	Part Number
22 - 44" W.C.	70017P125
40 - 84" W.C.	70017P126
3 - 5 PSIG	70017P127
4 - 7 PSIG	70017P128
7.8 - 14.5 PSIG	70017P129
14.5 - 29 PSIG	70017P130
29 - 58 PSIG	70017P131

#### External Sense

The 1803M PFM and the 1883M PFM have an external sense line connection and isolation assembly that allows a remote pressure to be introduced under the main diaphragm. Common uses of this feature would be in worker/monitor applications or where downstream turbulence is resulting in poor pressure control.

A worker/monitor regulator installation consists of a regulator with an external sense connection and a regulator with an internal sense connection. The regulator selected to be the monitor is typically set at 1/2 PSI above the worker regulator for set pressures under 2 PSI and 1-2 PSI above the worker regulators with set pressures above 2 PSI. Upstream monitoring, as shown in the sketch below, is more commonly used. The external sense line should be connected at a point free of turbulence and preferably a minimum of five pipe diameters downstream of the second regulator. A worker-to-monitor conversion kit (part number 73909K012) is available.

#### Typical Upstream Monitor Installation

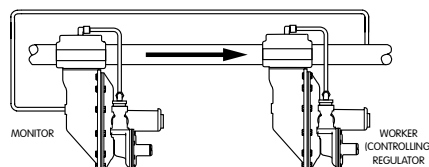

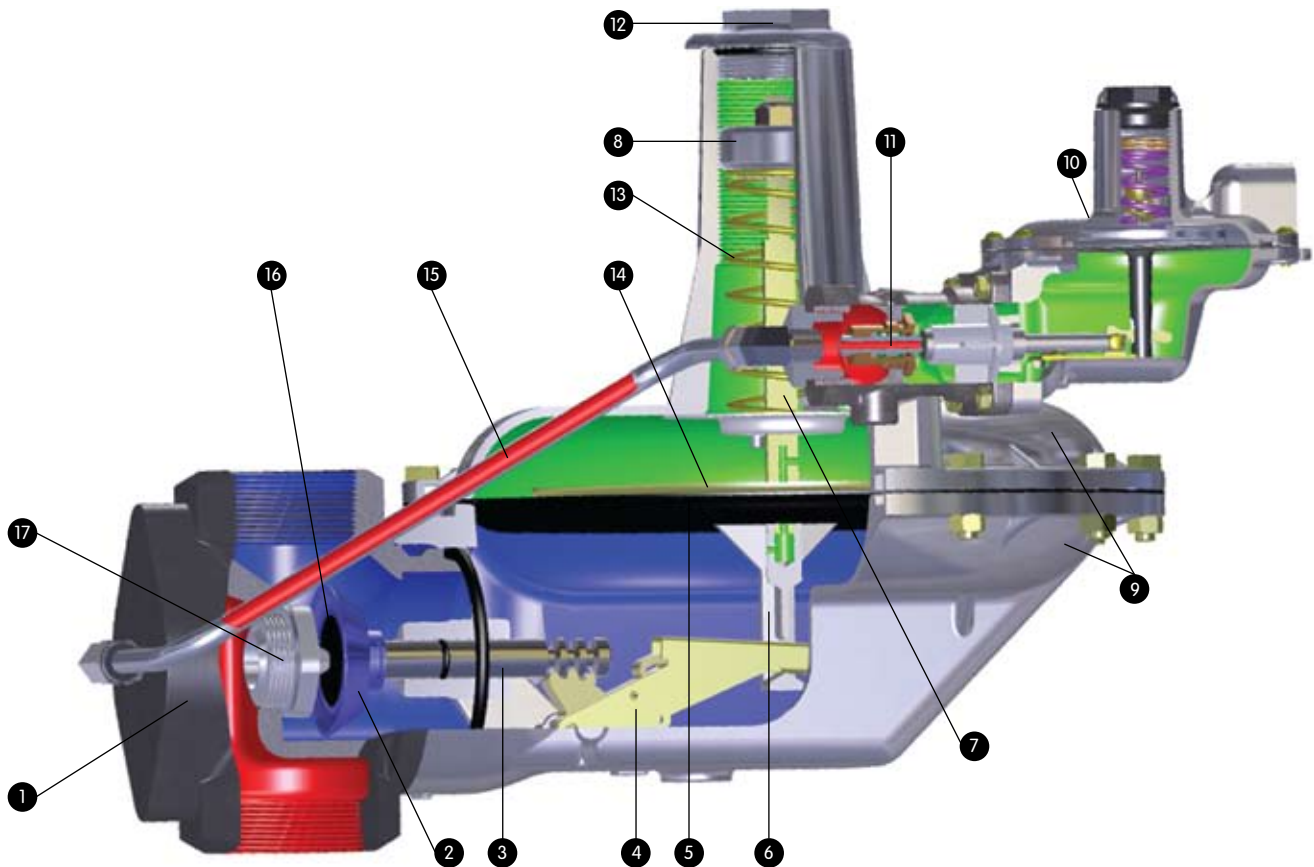

## Material Specifications

- 1 Valve Body - High tensile ductile iron. Threaded or flange connections. Undercoated, electrodeposition epoxy primer and high solids polyurethane top coat. NPT threads conform to ANSI/ASME B1.20.1. BSP-TR threads conform to BS EN 10226.
- 2 Seat Holder - Aluminum, anodized.
- 3 Plunger Valve Shaft - Stainless steel.
- 4 Lever Arm - Steel; Gear - Steel, sintered.
- 5 Diaphragm - Buna N, Nylon fabric reinforced.
- 6 Diaphragm Stem - Aluminum.
- 7 Spring Rod - Steel, Plated; Spring.
- 8 Follower - Aluminum.
- 9 Diaphragm Case - Precision die-cast aluminum with a proprietary conversion coating, electrodeposition epoxy primer and high solids polyurethane top coat.

- 10 Pilot Regulator - Outlet pressure is controlled by the pilot. Four pressure ranges are available.

Pressure Range	Part Numbers	
	Relieving Pilot	Non-Relieving Pilot
1 to 2 PSIG	52744K007	52744K008
2 to 6 PSIG	52744K001	52744K004
7 to 15 PSIG	52744K002	52744K005
16 to 30 PSIG	52744K003	52744K006

- 11 Elevation Compensating (EC) Orifice (Pilot) - Compensates for wide variations in inlet pressure, eliminating the inlet pressure effect. Large orifice provides fast response to sudden load changes.
- 12 Seal Plug - Cast aluminum.
- 13 Closing Spring - Steel, zinc plated and yellow chromate. Color coded (Black-Yellow) for identification.
- 14 Diaphragm Plates - Steel, zinc plated and yellow chromate.

- 15 Pilot Supply Tube - Steel, stainless.
- 16 Seat Disc - Buna N; 60, 70 or 80 durometer rating.
- 17 Orifice Valve - Aluminum.

Orifice Size	1803 PFM	1883 PFM with OPSO
1/4"	72983P010	72983P036
3/8"	72983P018	72983P033
5/8"	72983P013	72983P034
7/8"	72983P015	72983P037
1"	72983P016	72983P038
1-1/4"	72983P017	72983P035

## Theory of Operation

The 1800 PFM Series is part of a family of pilot-loaded regulators that provide a precise outlet pressure, increased capacity, and fast response to changing loads. It is designed to handle inlet pressures up to 125 PSIG with a variety of outlet pressures ranging from: 1 to 2 PSIG; 2 to 6 PSIG; 7 to 15 PSIG; and 16 to 30 PSIG depending on pilot selection. Since it can maintain outlet pressure within  $\pm 1\%$  of absolute set pressure, this regulator is ideal for fixed factor measurement at metering pressures from 1 to 30 PSIG.

The main regulator is normally closed, using one spring for all outlet pressures to close the main valve when downstream load is off. The external pilot regulator applies a constant control pressure (Green) to the top of the main diaphragm. An increase in downstream load causes a pressure decrease under the diaphragm (Blue) thereby allowing the higher control pressure on top of the diaphragm to open the main valve. When downstream load decreases the slight pressure build-up

under the main diaphragm overcomes the control pressure to close the main valve. The large bleed path in the diaphragm stem provides fast response to changing loads.

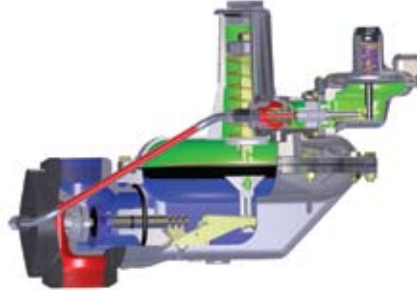

The 1800 PFM's pilot has an Elevation Compensating (EC) orifice that eliminates the inlet pressure effect found in most regulators. As the line pressure to the pilot increases, the EC orifice will move slightly towards the seat disk, compensating for the inlet pressure effect and assuring the outlet pressure remains the same.

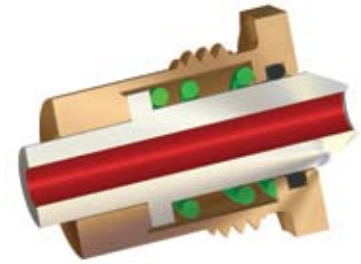

The EC orifice also improves the response time of the main regulator. This is accomplished by using a larger orifice which is pressure compensating and allows for higher pilot flow. This pilot flow is matched to the bleed passage through the diaphragm stem to provide a fast response to sudden changing loads.

Outlet pressure is set by means of an adjustment screw in the pilot. Pilots can be equipped with a partial relief valve.

## Fixed Factor Measurement

Fixed factor measurement is widely used as a means of economically metering and billing at elevated pressures without the use of a volume corrector. By controlling the metering pressure precisely to within  $\pm 1\%$  of the absolute outlet pressure, a standard index reading or a pressure compensating index can be used on the meter.

For example, a meter installed at a location where atmospheric pressure is 14.7 PSIA with 5 PSIG flowing pressure would have an absolute outlet pressure of 19.7 PSIA.

The 1800 PFM is capable of maintaining the outlet pressure to within  $\pm 1\%$  of the absolute outlet pressure ( $19.7 \times 0.01 = \pm 0.197$  PSIG) when set at 5 PSIG outlet.

## Typical Performance Data

Model No. 1800 PFM

Set Inlet Pressure  $P_1$ : 60 PSIG

Set Outlet Pressure  $P_2$ : Various

Set Flow: 200 SCFH

Test Medium: 0.60 Sp. Gr. Gas  
14.7 PSIA at 60°F

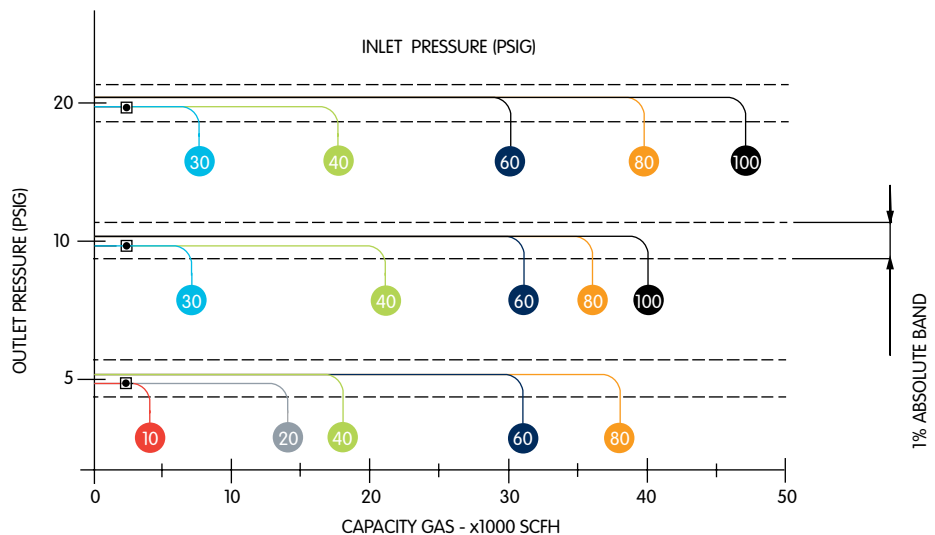

# 1800 PFM Series Regulator Capacity Performance

## 1-1/2" Outlet

### Set Point 1 PSIG (0.07 bar) at 200 SCFH

SCFH (m<sup>3</sup>/h) 0.60 specific gravity gas at 60°F and 14.7 PSIA (15.6°C and 1.01 bar). Outlet pressure variance not to exceed ±1% (Absolute Pressure)

### 1800 PFM Series Regulator Capacity SCFH (m<sup>3</sup>/h)

Inlet PSIG (bar)	1/4" Orifice	3/8" Orifice	5/8" Orifice	7/8" Orifice	1" Orifice	1 1/4" Orifice
10 (0.69)	1200 (34.0)	1500 (42.5)	2400 (68.0)	2200 (62.3)	5200 (147.3)	5200 (147.3)
15 (1.03)	1350 (38.2)	2300 (65.1)	5800 (164.3)	5800 (164.3)	8500 (240.7)	8800 (249.2)
20 (1.38)	1900 (53.8)	3400 (96.3)	8000 (226.6)	8000 (226.6)	12,400 (351.2)	12,400 (351.2)
30 (2.07)	2800 (79.3)	5500 (155.8)	12,900 (365.3)	13,200 (373.8)	18,400 (521.1)	18,200 (515.4)
40 (2.76)	3600 (102.0)	7600 (215.2)	16,000 (453.1)	16,000 (453.1)	—	—
60 (4.14)	4950 (140.2)	10,900 (308.7)	—	—	—	—
80 (5.52)	—	—	—	—	—	—
100 (6.90)	—	—	—	—	—	—
125 (8.62)	—	—	—	—	—	—

### Set Point 2 PSIG (0.14 bar) at 200 SCFH

SCFH (m<sup>3</sup>/h) 0.60 specific gravity gas at 60°F and 14.7 PSIA (15.6°C and 1.01 bar). Outlet pressure variance not to exceed ±1% (Absolute Pressure)

### 1800 PFM Series Regulator Capacity SCFH (m<sup>3</sup>/h)

Inlet PSIG (bar)	1/4" Orifice	3/8" Orifice	5/8" Orifice	7/8" Orifice	1" Orifice	1 1/4" Orifice
10 (0.69)	1200 (34.0)	2100 (59.5)	4150 (117.5)	6000 (169.9)	5050 (143.0)	8000 (226.6)
15 (1.03)	1650 (46.7)	3400 (96.3)	7000 (198.2)	8250 (233.6)	7350 (208.2)	10,450 (295.9)
20 (1.38)	1900 (53.8)	4300 (121.8)	9350 (264.8)	10,000 (283.2)	10,550 (298.8)	12,400 (351.2)
30 (2.07)	2300 (65.1)	5750 (162.8)	13,150 (372.4)	18,150 (514.0)	18,000 (509.8)	19,050 (539.5)
40 (2.76)	3150 (89.2)	7150 (202.5)	15,750 (446.0)	20,150 (570.6)	23,000 (651.4)	23,200 (657.0)
60 (4.14)	4350 (123.2)	9900 (280.4)	22,300 (631.5)	27,350 (774.6)	20,350 (576.3)	—
80 (5.52)	5550 (157.2)	12,600 (356.8)	25,650 (726.4)	22,300 (631.5)	—	—
100 (6.90)	6500 (184.1)	14,200 (402.1)	26,450 (749.1)	—	—	—
125 (8.62)	7500 (212.4)	16,000 (453.1)	—	—	—	—

# 1800 PFM Series Regulator Capacity Performance

## 1-1/2" Outlet

### Set Point 5 PSIG (0.34 bar) at 200 SCFH

SCFH (m<sup>3</sup>/h) 0.60 specific gravity gas at 60°F and 14.7 PSIA (15.6°C and 1.01 bar). Outlet pressure variance not to exceed ±1% (Absolute Pressure)

### 1800 PFM Series Regulator Capacity SCFH (m<sup>3</sup>/h)

Inlet PSIG (bar)	1/4" Orifice	3/8" Orifice	5/8" Orifice	7/8" Orifice	1" Orifice	1 1/4" Orifice
10 (0.69)	1150 (32.6)	2350 (66.6)	3400 (96.3)	4150 (117.5)	4500 (127.4)	8100 (229.4)
15 (1.03)	1600 (45.3)	3400 (96.3)	6850 (194.0)	7750 (219.5)	7000 (198.2)	10,000 (283.2)
20 (1.38)	1900 (53.8)	4150 (117.5)	9000 (254.9)	10,050 (284.6)	11,250 (318.6)	12,600 (356.8)
30 (2.07)	2300 (65.1)	5750 (162.8)	13,850 (392.2)	17,000 (481.4)	18,000 (509.8)	19,600 (555.1)
40 (2.76)	3150 (89.2)	7100 (201.1)	16,350 (463.0)	21,600 (611.7)	22,500 (637.2)	25,750 (729.2)
60 (4.14)	4350 (123.2)	9900 (280.4)	23,750 (672.6)	31,000 (877.9)	28,950 (819.9)	—
80 (5.52)	5550 (157.2)	12,600 (356.8)	28,450 (805.7)	32,200 (911.9)	—	—
100 (6.90)	6500 (184.1)	14,600 (413.5)	30,150 (853.8)	—	—	—
125 (8.62)	7500 (212.4)	16,000 (453.1)	—	—	—	—

### Set Point 10 PSIG (0.69 bar) at 200 SCFH

SCFH (m<sup>3</sup>/h) 0.60 specific gravity gas at 60°F and 14.7 PSIA (15.6°C and 1.01 bar). Outlet pressure variance not to exceed ±1% (Absolute Pressure)

### 1800 PFM Series Regulator Capacity SCFH (m<sup>3</sup>/h)

Inlet PSIG (bar)	1/4" Orifice	3/8" Orifice	5/8" Orifice	7/8" Orifice	1" Orifice	1 1/4" Orifice
10 (0.69)	—	—	—	—	—	—
15 (1.03)	1000 (28.3)	2200 (62.3)	3600 (102.0)	5000 (141.6)	6000 (169.9)	8100 (229.4)
20 (1.38)	1500 (42.5)	3150 (89.2)	4700 (133.1)	5550 (157.2)	9000 (254.9)	14,400 (407.8)
30 (2.07)	2200 (62.3)	4250 (120.4)	10,250 (290.3)	12,250 (346.9)	13,150 (372.4)	23,550 (666.9)
40 (2.76)	3050 (86.4)	6750 (191.2)	16,350 (463.0)	18,550 (525.3)	22,000 (623.0)	29,350 (831.2)
60 (4.14)	4350 (123.2)	9900 (280.4)	26,100 (739.2)	32,650 (924.6)	39,000 (1104.5)	—
80 (5.52)	5550 (157.2)	12,600 (356.8)	32,550 (921.8)	36,250 (1026.6)	—	—
100 (6.90)	6600 (186.9)	14,650 (414.9)	34,350 (972.8)	—	—	—
125 (8.62)	7550 (213.8)	16,000 (453.1)	—	—	—	—

# 1800 PFM Series Regulator Capacity Performance

## 1-1/2" Outlet

### Set Point 15 PSIG (1.03 bar) at 200 SCFH

SCFH (m<sup>3</sup>/h) 0.60 specific gravity gas at 60°F and 14.7 PSIA (15.6°C and 1.01 bar). Outlet pressure variance not to exceed ±1% (Absolute Pressure)

### 1800 PFM Series Regulator Capacity SCFH (m<sup>3</sup>/h)

Inlet PSIG (bar)	1/4" Orifice	3/8" Orifice	5/8" Orifice	7/8" Orifice	1" Orifice	1 1/4" Orifice
10 (0.69)	—	—	—	—	—	—
15 (1.03)	—	—	—	—	—	—
20 (1.38)	1200 (34.0)	2600 (73.6)	4600 (130.3)	3400 (96.3)	9900 (280.4)	10,050 (284.6)
30 (2.07)	2150 (60.9)	4200 (118.9)	10,250 (290.3)	12,000 (339.8)	16,000 (453.1)	23,950 (678.3)
40 (2.76)	3000 (85.0)	5050 (143.0)	15,650 (443.2)	19,800 (560.7)	22,000 (623.0)	31,350 (887.8)
60 (4.14)	4500 (127.4)	9700 (274.7)	26,450 (749.1)	36,450 (1032.3)	39,000 (1104.5)	—
80 (5.52)	5600 (158.6)	12,400 (351.2)	32,950 (933.1)	39,750 (1125.7)	—	—
100 (6.90)	6600 (187.0)	14,600 (413.5)	33,850 (958.6)	—	—	—
125 (8.62)	7500 (212.4)	16,000 (453.1)	—	—	—	—

### Set Point 20 PSIG (1.38 bar) at 200 SCFH

SCFH (m<sup>3</sup>/h) 0.60 specific gravity gas at 60°F and 14.7 PSIA (15.6°C and 1.01 bar). Outlet pressure variance not to exceed ±1% (Absolute Pressure)

### 1800 PFM Series Regulator Capacity SCFH (m<sup>3</sup>/h)

Inlet PSIG (bar)	1/4" Orifice	3/8" Orifice	5/8" Orifice	7/8" Orifice	1" Orifice	1 1/4" Orifice
10 (0.69)	—	—	—	—	—	—
15 (1.03)	—	—	—	—	—	—
20 (1.38)	—	—	—	—	—	—
30 (2.07)	1750 (49.6)	4050 (114.7)	5650 (160.0)	9400 (266.2)	10,800 (305.9)	21,250 (601.8)
40 (2.76)	2700 (76.5)	4750 (134.5)	15,100 (427.6)	19,000 (538.1)	22,500 (637.2)	32,200 (911.9)
60 (4.14)	4400 (124.6)	9650 (273.3)	26,250 (743.4)	36,350 (1029.4)	41,150 (1165.4)	—
80 (5.52)	5600 (158.6)	12,250 (346.9)	32,750 (927.5)	44,250 (1253.2)	—	—
100 (6.90)	6600 (186.9)	14,200 (402.1)	32,750 (927.5)	—	—	—
125 (8.62)	7500 (212.4)	15,800 (447.5)	—	—	—	—

# 1800 PFM Series Regulator Capacity Performance

## 1-1/2" Outlet

### Set Point 25 PSIG (1.72 bar) at 200 SCFH

SCFH (m<sup>3</sup>/h) 0.60 specific gravity gas at 60°F and 14.7 PSIA (15.6°C and 1.01 bar). Outlet pressure variance not to exceed ±1% (Absolute Pressure)

### 1800 PFM Series Regulator Capacity SCFH (m<sup>3</sup>/h)

Inlet PSIG (bar)	1/4" Orifice	3/8" Orifice	5/8" Orifice	7/8" Orifice	1" Orifice	1 1/4" Orifice
10 (0.69)	—	—	—	—	—	—
15 (1.03)	—	—	—	—	—	—
20 (1.38)	—	—	—	—	—	—
30 (2.07)	1200 (33.9)	3450 (97.7)	6250 (177.0)	9000 (254.9)	11,600 (328.5)	14,200 (402.1)
40 (2.76)	2300 (65.1)	4600 (130.3)	10,450 (295.9)	15,500 (439.0)	22,500 (637.2)	30,600 (866.6)
60 (4.14)	4350 (123.2)	9450 (267.6)	24,850 (703.8)	36,350 (1029.4)	41,500 (1175.3)	—
80 (5.52)	5550 (157.2)	12,150 (344.1)	32,200 (911.9)	45,500 (1288.6)	—	—
100 (6.90)	6600 (186.9)	13,950 (395.1)	31,500 (892.1)	—	—	—
125 (8.62)	7500 (212.4)	15,300 (433.3)	—	—	—	—

### Set Point 30 PSIG (2.07 bar) at 200 SCFH

SCFH (m<sup>3</sup>/h) 0.60 specific gravity gas at 60°F and 14.7 PSIA (15.6°C and 1.01 bar). Outlet pressure variance not to exceed ±1% (Absolute Pressure)

### 1800 PFM Series Regulator Capacity SCFH (m<sup>3</sup>/h)

Inlet PSIG (bar)	1/4" Orifice	3/8" Orifice	5/8" Orifice	7/8" Orifice	1" Orifice	1 1/4" Orifice
10 (0.69)	—	—	—	—	—	—
15 (1.03)	—	—	—	—	—	—
20 (1.38)	—	—	—	—	—	—
30 (2.07)	—	—	—	—	—	—
40 (2.76)	2050 (58.1)	4300 (121.8)	9700 (274.7)	12,150 (344.1)	11,500 (325.7)	24,300 (688.2)
60 (4.14)	4200 (118.9)	9200 (260.5)	23,400 (662.7)	36,000 (1019.5)	41,750 (1182.4)	—
80 (5.52)	5400 (152.9)	12,150 (344.1)	30,400 (860.9)	45,500 (1288.6)	—	—
100 (6.90)	6650 (188.3)	13,750 (389.4)	32,950 (933.1)	—	—	—
125 (8.62)	7500 (212.4)	15,300 (433.3)	—	—	—	—

# 1800 PFM Series Regulator Capacity Performance

## 2" Outlet

### Set Point 1 PSIG (0.07 bar) at 200 SCFH

SCFH (m<sup>3</sup>/h) 0.60 specific gravity gas at 60°F and 14.7 PSIA (15.6°C and 1.01 bar). Outlet pressure variance not to exceed ±1% (Absolute Pressure)

### 1800 PFM Series Regulator Capacity SCFH (m<sup>3</sup>/h)

Inlet PSIG (bar)	1/4" Orifice	3/8" Orifice	5/8" Orifice	7/8" Orifice	1" Orifice	1 1/4" Orifice
10 (0.69)	1000 (28.3)	1600 (45.3)	2100 (59.5)	2000 (56.6)	4200 (118.9)	7100 (201.1)
15 (1.03)	1200 (34.0)	2500 (70.8)	4500 (127.4)	5100 (144.4)	7500 (212.4)	10,900 (308.7)
20 (1.38)	1500 (42.5)	3400 (96.3)	5900 (167.1)	8200 (232.2)	10,600 (300.2)	18,800 (532.4)
30 (2.07)	2300 (65.1)	5200 (147.3)	10,900 (308.7)	15,800 (447.5)	18,400 (521.1)	26,800 (759.0)
40 (2.76)	3300 (93.5)	6600 (186.9)	16,000 (453.1)	24,600 (696.7)	23,000 (651.4)	—
60 (4.14)	4900 (138.8)	9800 (277.5)	—	—	—	—
80 (5.52)	—	—	—	—	—	—
100 (6.90)	—	—	—	—	—	—
125 (8.62)	—	—	—	—	—	—

### Set Point 2 PSIG (0.14 bar) at 200 SCFH

SCFH (m<sup>3</sup>/h) 0.60 specific gravity gas at 60°F and 14.7 PSIA (15.6°C and 1.01 bar). Outlet pressure variance not to exceed ±1% (Absolute Pressure)

### 1800 PFM Series Regulator Capacity SCFH (m<sup>3</sup>/h)

Inlet PSIG (bar)	1/4" Orifice	3/8" Orifice	5/8" Orifice	7/8" Orifice	1" Orifice	1 1/4" Orifice
10 (0.69)	1000 (28.3)	2300 (65.1)	4700 (133.1)	4700 (133.1)	10,000 (283.2)	10,200 (288.9)
15 (1.03)	1450 (41.1)	3000 (85.0)	6200 (175.6)	9000 (254.9)	14,500 (410.6)	25,000 (708.0)
20 (1.38)	1900 (53.8)	3900 (110.4)	8500 (240.7)	10,100 (286.0)	21,600 (611.7)	30,600 (866.6)
30 (2.07)	2500 (70.8)	5200 (147.3)	12,500 (354.0)	18,000 (509.8)	31,500 (892.1)	40,300 (1141.3)
40 (2.76)	3100 (87.8)	6000 (169.9)	18,000 (509.8)	24,000 (679.7)	38,500 (1090.3)	41,000 (1161.1)
60 (4.14)	4400 (124.6)	9000 (254.9)	27,000 (764.6)	20,000 (566.4)	52,000 (1472.6)	—
80 (5.52)	5500 (155.8)	11,500 (325.7)	24,000 (679.7)	20,000 (566.4)	—	—
100 (6.90)	6700 (189.7)	14,400 (407.8)	18,000 (509.8)	—	—	—
125 (8.62)	8200 (232.2)	17,600 (498.4)	—	—	—	—

# 1800 PFM Series Regulator Capacity Performance

## 2" Outlet

### Set Point 5 PSIG (0.34 bar) at 200 SCFH

SCFH (m<sup>3</sup>/h) 0.60 specific gravity gas at 60°F and 14.7 PSIA (15.6°C and 1.01 bar). Outlet pressure variance not to exceed ±1% (Absolute Pressure)

### 1800 PFM Series Regulator Capacity SCFH (m<sup>3</sup>/h)

Inlet PSIG (bar)	1/4" Orifice	3/8" Orifice	5/8" Orifice	7/8" Orifice	1" Orifice	1 1/4" Orifice
10 (0.69)	900 (25.5)	1350 (38.2)	2700 (76.5)	4300 (121.8)	9000 (254.9)	12,200 (345.5)
15 (1.03)	1300 (36.8)	2500 (70.8)	6200 (175.6)	9000 (254.9)	16,000 (453.1)	21,800 (617.4)
20 (1.38)	1900 (53.8)	3400 (96.3)	8300 (235.1)	12,000 (339.8)	21,000 (594.7)	29,100 (824.1)
30 (2.07)	2500 (70.8)	4850 (137.4)	12,200 (345.5)	20,000 (566.4)	30,600 (866.6)	41,700 (1180.9)
40 (2.76)	3100 (87.8)	6200 (175.6)	18,000 (509.8)	25,000 (708.0)	39,000 (1104.5)	44,000 (1246.1)
60 (4.14)	4400 (124.6)	9000 (254.9)	27,000 (764.6)	31,000 (877.9)	52,000 (1472.6)	—
80 (5.52)	5450 (154.3)	11,500 (325.7)	32,500 (920.4)	32,000 (906.2)	—	—
100 (6.90)	6700 (189.7)	14,300 (405.0)	28,000 (793.0)	—	—	—
125 (8.62)	8200 (232.2)	17,400 (492.8)	—	—	—	—

### Set Point 10 PSIG (0.69 bar) at 200 SCFH

SCFH (m<sup>3</sup>/h) 0.60 specific gravity gas at 60°F and 14.7 PSIA (15.6°C and 1.01 bar). Outlet pressure variance not to exceed ±1% (Absolute Pressure)

### 1800 PFM Series Regulator Capacity SCFH (m<sup>3</sup>/h)

Inlet PSIG (bar)	1/4" Orifice	3/8" Orifice	5/8" Orifice	7/8" Orifice	1" Orifice	1 1/4" Orifice
10 (0.69)	—	—	—	—	—	—
15 (1.03)	350 (9.9)	2500 (70.8)	5600 (158.6)	5100 (144.4)	—	—
20 (1.38)	700 (19.8)	3150 (89.2)	7800 (220.9)	10,500 (297.4)	13,000 (368.1)	10,800 (305.9)
30 (2.07)	2100 (59.5)	4400 (124.6)	12,000 (339.8)	20,000 (566.4)	27,700 (784.5)	32,750 (927.5)
40 (2.76)	3000 (85.0)	6200 (175.6)	17,500 (495.6)	28,000 (793.0)	39,250 (1111.6)	45,000 (1274.4)
60 (4.14)	4300 (121.8)	9000 (254.9)	27,000 (764.6)	46,000 (1302.7)	56,100 (1588.8)	—
80 (5.52)	5400 (152.9)	12,400 (351.2)	34,300 (971.4)	52,000 (1472.6)	—	—
100 (6.90)	6600 (186.9)	14,350 (406.4)	40,500 (1147.0)	—	—	—
125 (8.62)	8300 (235.1)	17,300 (489.9)	—	—	—	—

# 1800 PFM Series Regulator Capacity Performance

## 2" Outlet

### Set Point 15 PSIG (1.03 bar) at 200 SCFH

SCFH (m<sup>3</sup>/h) 0.60 specific gravity gas at 60°F and 14.7 PSIA (15.6°C and 1.01 bar). Outlet pressure variance not to exceed ±1% (Absolute Pressure)

### 1800 PFM Series Regulator Capacity SCFH (m<sup>3</sup>/h)

Inlet PSIG (bar)	1/4" Orifice	3/8" Orifice	5/8" Orifice	7/8" Orifice	1" Orifice	1 1/4" Orifice
10 (0.69)	—	—	—	—	—	—
15 (1.03)	—	—	—	—	—	—
20 (1.38)	750 (21.2)	2850 (80.7)	5050 (143.0)	6900 (195.4)	9300 (263.3)	6100 (172.8)
30 (2.07)	2100 (59.5)	4850 (137.4)	12,000 (339.8)	16,000 (453.1)	24,100 (682.5)	30,250 (856.7)
40 (2.76)	3000 (85.0)	5400 (152.9)	16,500 (467.3)	28,000 (793.0)	35,600 (1008.2)	43,900 (1243.2)
60 (4.14)	4200 (118.9)	9000 (254.9)	27,000 (764.6)	46,000 (1302.7)	56,150 (1590.2)	—
80 (5.52)	5350 (151.5)	12,400 (351.2)	34,200 (968.5)	52,000 (1472.6)	—	—
100 (6.90)	6700 (189.7)	14,350 (406.4)	40,500 (1147.0)	—	—	—
125 (8.62)	8300 (235.1)	17,300 (489.9)	—	—	—	—

### Set Point 20 PSIG (1.38 bar) at 200 SCFH

SCFH (m<sup>3</sup>/h) 0.60 specific gravity gas at 60°F and 14.7 PSIA (15.6°C and 1.01 bar). Outlet pressure variance not to exceed ±1% (Absolute Pressure)

### 1800 PFM Series Regulator Capacity SCFH (m<sup>3</sup>/h)

Inlet PSIG (bar)	1/4" Orifice	3/8" Orifice	5/8" Orifice	7/8" Orifice	1" Orifice	1 1/4" Orifice
10 (0.69)	—	—	—	—	—	—
15 (1.03)	—	—	—	—	—	—
20 (1.38)	—	—	—	—	—	—
30 (2.07)	1700 (48.1)	2800 (79.3)	7,500 (212.4)	13,000 (368.2)	18,000 (509.8)	18,300 (518.3)
40 (2.76)	2800 (79.3)	4100 (116.1)	11,000 (311.5)	27,000 (764.6)	34,000 (962.9)	34,500 (977.0)
60 (4.14)	4200 (118.9)	8000 (226.6)	26,000 (736.3)	47,000 (1331.0)	51,450 (1457.1)	—
80 (5.52)	5300 (150.1)	11,500 (325.7)	33,800 (957.2)	58,000 (1642.6)	—	—
100 (6.90)	6700 (189.7)	14,000 (396.5)	40,000 (1132.8)	—	—	—
125 (8.62)	8300 (235.1)	17,200 (487.1)	—	—	—	—

# 1800 PFM Series Regulator Capacity Performance

## 2" Outlet

### Set Point 25 PSIG (1.72 bar) at 200 SCFH

SCFH (m<sup>3</sup>/h) 0.60 specific gravity gas at 60°F and 14.7 PSIA (15.6°C and 1.01 bar). Outlet pressure variance not to exceed ±1% (Absolute Pressure)

### 1800 PFM Series Regulator Capacity SCFH (m<sup>3</sup>/h)

Inlet PSIG (bar)	1/4" Orifice	3/8" Orifice	5/8" Orifice	7/8" Orifice	1" Orifice	1 1/4" Orifice
10 (0.69)	—	—	—	—	—	—
15 (1.03)	—	—	—	—	—	—
20 (1.38)	—	—	—	—	—	—
30 (2.07)	700 (19.8)	3450 (97.7)	6150 (174.1)	8800 (249.2)	11,500 (325.7)	14,400 (407.8)
40 (2.76)	2500 (70.8)	4100 (116.1)	10,000 (283.2)	20,000 (566.4)	27,300 (773.1)	38,500 (1090.3)
60 (4.14)	4200 (118.9)	7000 (198.2)	24,300 (688.2)	44,000 (1246.1)	51,100 (1447.2)	—
80 (5.52)	5300 (150.1)	11,000 (311.52)	34,000 (962.9)	59,000 (1670.9)	—	—
100 (6.90)	6700 (189.7)	14,200 (402.1)	40,000 (1132.8)	—	—	—
125 (8.62)	8300 (235.1)	17,100 (484.3)	—	—	—	—

### Set Point 30 PSIG (2.07 bar) at 200 SCFH

SCFH (m<sup>3</sup>/h) 0.60 specific gravity gas at 60°F and 14.7 PSIA (15.6°C and 1.01 bar). Outlet pressure variance not to exceed ±1% (Absolute Pressure)

### 1800 PFM Series Regulator Capacity SCFH (m<sup>3</sup>/h)

Inlet PSIG (bar)	1/4" Orifice	3/8" Orifice	5/8" Orifice	7/8" Orifice	1" Orifice	1 1/4" Orifice
10 (0.69)	—	—	—	—	—	—
15 (1.03)	—	—	—	—	—	—
20 (1.38)	—	—	—	—	—	—
30 (2.07)	—	—	—	—	—	—
40 (2.76)	1200 (34.0)	4100 (116.1)	7000 (198.2)	14,000 (396.5)	23,400 (662.7)	32,400 (917.6)
60 (4.14)	4000 (113.3)	7000 (198.2)	23,000 (651.4)	42,500 (1203.6)	46,800 (1325.4)	—
80 (5.52)	5300 (150.1)	11,000 (311.5)	34,300 (971.4)	60,000 (1699.2)	—	—
100 (6.90)	6700 (189.7)	14,100 (399.3)	40,000 (1132.8)	—	—	—
125 (8.62)	8300 (235.1)	17,100 (484.3)	—	—	—	—

# 1800 PFM Series Regulators - Other Technical Data

## Full-Open Regulator Relief Capacity

For sizing downstream relief valves, use the following formulas to determine the regulator full-open capacity:

Critical flow rates      Sub-critical flows

$$Q = 0.5 C \times \frac{P_1}{\sqrt{G}} \quad Q = C \times \frac{\sqrt{P_2 h}}{\sqrt{G}}$$

Critical flow occurs when the absolute outlet pressure is less than about 1/2 of the absolute inlet pressure.

- Q Maximum capacity of regulator
- C Orifice constant (see table below)
- P<sub>1</sub> Inlet absolute pressure (PSIA)
- P<sub>2</sub> Outlet absolute pressure (PSIA)
- h Differential pressure
- G Specific gravity of gas

## Orifice Constants

Orifice	C
1/4"	110
3/8"	226
5/8"	600
7/8"	1100
1"	1425
1-1/4"	2150

## Other Gas Capacities

To determine the capacity of these regulators for gases other than natural gas, multiply the values within the capacity tables by a Specific Gravity Conversion Factor (F<sub>g</sub>). The table below lists this factor for some of the more common gases.

Gas Type	Specific Gravity	Conversion Factor (F <sub>g</sub> )
Air	1.00	0.77
Butane	2.01	0.55
Carbon Dioxide	1.52	0.63
Nitrogen	0.97	0.79
Propane	1.53	0.63

To calculate the Conversion Factor for other gases:

$$(F_g) = \sqrt{\frac{\text{Specific gravity of gas on which table is based}}{\text{Specific gravity of gas being used}}}$$

Example: If using propane, the Specific Gravity Conversion Factor is :

$$(F_g) = \sqrt{\frac{\text{Specific gravity of natural gas (0.6)}}{\text{Specific gravity of propane (1.53)}}}$$

$$(F_g) = \sqrt{\frac{0.60}{1.53}}$$

$$(F_g) = 0.626$$

## Regulator Pressure Rating

125 PSIG (8.6 bar) = Maximum recommended inlet pressure for normal service. Maximum recommended pressure may vary with orifice size.

160 PSIG (12 bar) = Maximum inlet pressure for abnormal or emergency service, without causing damage to regulator case.

30 PSIG (138 mbar) = Maximum outlet pressure for normal service.

35 PSIG (689 mbar) = Maximum outlet pressure which can be contained by pressure carrying components (no flange leakage to atmosphere except for normal relief action). **If regulator is subjected to these conditions, it should be removed from service.**

40 PSIG (3.5 bar) = Maximum outlet pressure for abnormal service without damage to internal components. **If regulator is subjected to these conditions, it should be removed from service.**

# 1800 PFM Series Regulator Dimensions

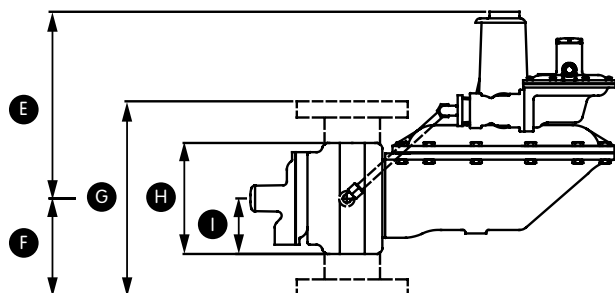
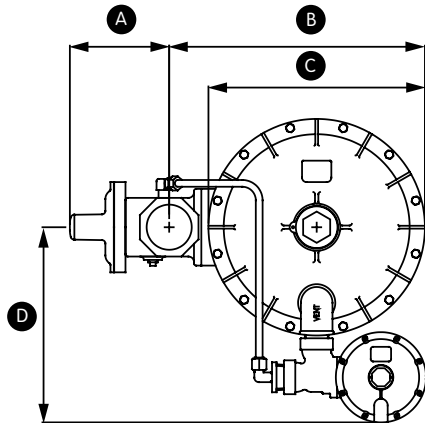
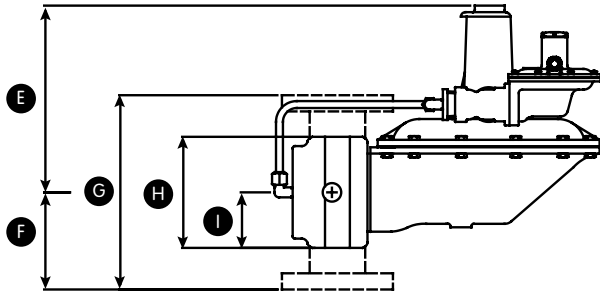
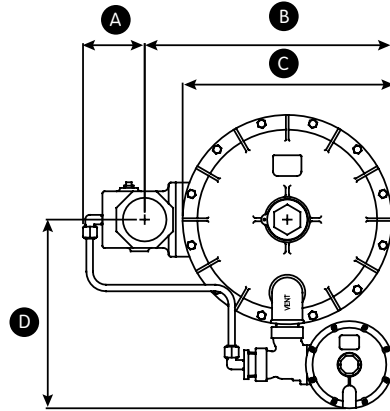

## Model 1803 PFM

1-1/2" and 2" Pilot Loaded Regulator

A	3-1/2"	88.9mm
B	14-1/4"	361.95mm
C	12"	304.8mm
D	10-3/4"	273.05mm
E	10"	254.0mm
F	5-1/4"	133.35mm
G	10-1/2" *	266.7mm
H	6"	152.4mm
I	3"	76.2mm

\* 10.00" (254mm) long value head also available

## Model 1883 PFM

1-1/2" and 2" Pilot Loaded Regulator

A	5-1/2"	139.7mm
B	14-1/4"	361.95mm
C	12"	304.8mm
D	10-3/4"	273.05mm
E	10"	254.0mm
F	5-1/4"	133.35mm
G	10-1/2" *	266.7mm
H	6"	152.4mm
I	3"	76.2mm

\* 10.00" (254mm) long value head also available

# Regulator Assembly Positions

## 1803 PFM

### Valve Head Position "A"

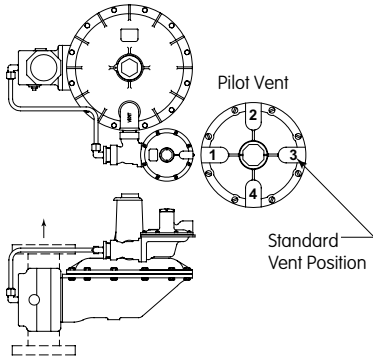

### Valve Head Position "B"

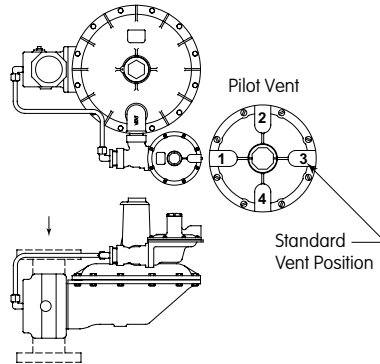

### Valve Head Position "C"

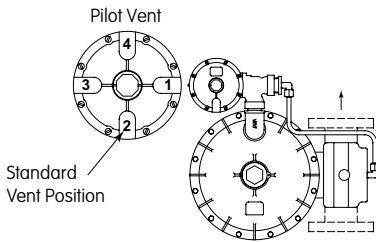

### Valve Head Position "D"

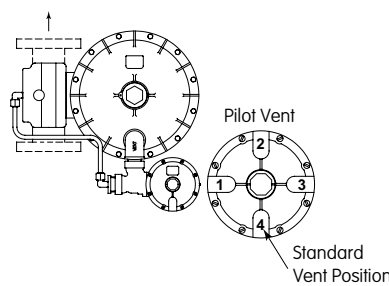

## 1883 PFM

### Valve Head Position "A"

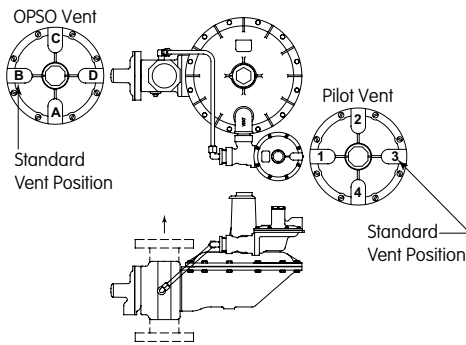

### Valve Head Position "B"

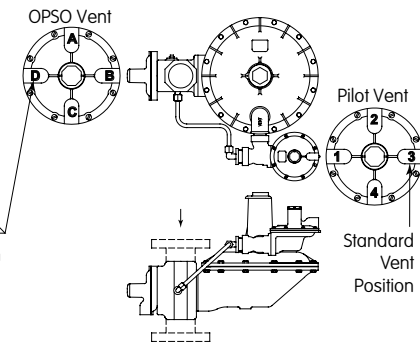

### Valve Head Position "C"

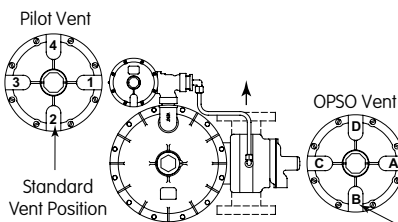

### Valve Head Position "D"

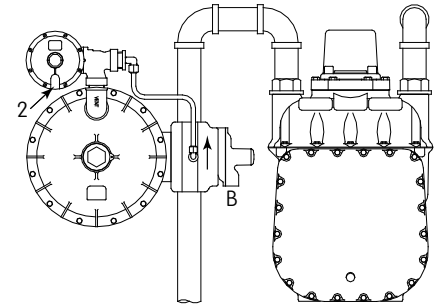
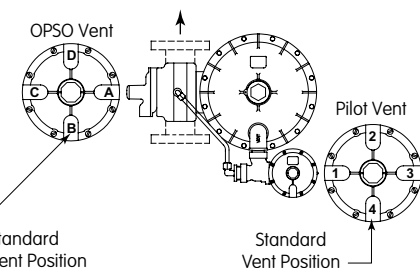

AL-1000 Meter with 1883 PFM Regulator

### Example of Regulator Assembly Position

In the above drawing the 1883 PFM regulator shown has the valve head in position "C" (Flow upward). The pilot vent is in position "2" (Pointed down) and the OPSO vent in position "B" (Also pointed down). This would be assembly position "C2B".

### Ordering Information

1. Model Number
2. Connection Size: 1-1/2" Threaded, 2" Threaded, 2" Flanged
3. Inlet Pressure Range: up to 125 PSIG
4. Outlet Set Pressure: 1 PSIG to 30 PSIG
5. Main Orifice Diameter: 1/4", 3/8", 5/8", 7/8", 1", 1-1/4"
6. Gas Specific Gravity
7. Regulator Assembly Position: See left
8. Pilot Filter Option: Yes/No
9. OPSO Spring Range: See page 2

### Shipping Weight

#### Model 1803 PFM

21 Lbs. – Threaded Connection  
35 Lbs. – Flanged Connection

### Shipping Weight

#### Model 1883 PFM

23.25 Lbs. – Threaded Connection  
37.25 Lbs. – Flanged Connection

## About Elster Group

A world leader in advanced metering infrastructure, integrated metering, and utilization solutions to the gas, electricity and water industries. Elster's metering and system solutions reflect over 170 years of knowledge and experience in measuring precious resources and energy.

Elster provides solutions and advanced technologies to help utilities more easily, efficiently and reliably obtain and use advanced metering intelligence to improve customer service, enhance operational efficiency, and increase revenues. Elster's AMI solutions enable utilities to cost-effectively generate, deliver, manage, and conserve the life-essential resources of gas, electricity, and water.

Elster has a staff of over 7,500 serving customers globally in North America, Central America, South America, Europe, Asia, Africa and the Middle East.

### ISO 9001: 2000



Certificate No. 006697

Elster American Meter  
2221 Industrial Road  
Nebraska City, NE 68410  
USA

T +1 402 873 8200  
F +1 402 873 7616

[www.elster-americanmeter.com](http://www.elster-americanmeter.com)

Elster Canadian Meter

T +1 905 634 4895  
F +1 905 634 6705

[www.elster-canadianmeter.com](http://www.elster-canadianmeter.com)

© 2009 Elster American Meter. All rights reserved.

Information contained herein is subject to change without notice. Product specifications may change. Contact your Elster American Meter representative for the most current product information. Printed in the United States.

EAM-TB8551.4-EN-P - January 2009  
Supersedes SB8551.3