

THERM-X-TROL®

Thermal Expansion Absorbers, ST-C Series (ASME) 150 PSIG Working Pressure

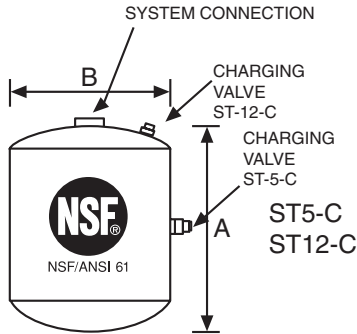

In-Line Models

Model No.	Tank Vol.		Max. Recomm. Accept Vol.		A Height		B Diameter		Sys. Conn.	Ship Wt.	
	Lit.	Gal.	Lit.	Gal.	mm	ins.	mm	ins.	ins.	kg	lbs.
ST-5-C	8	2.1	3.44	.9	264	10 ³ / ₈	254	10	¾ NPTF	9	19.7
ST-12-C	24	6.4	12.0	3.2	340	13 ³ / ₈	305	12	¾ NPTF	15	33.8

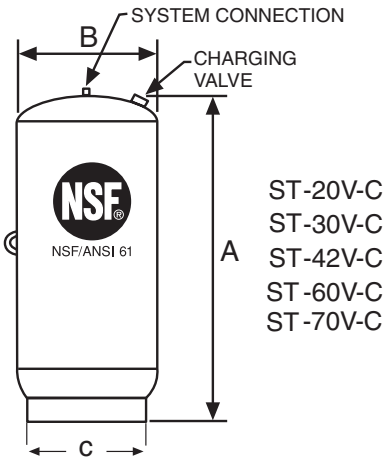

Stand Models

Model No.	Tank Vol.		Max. Recomm. Accept. Vol.		A Height		B Diameter		C Dim.		Sys. Conn.	Ship Wt.	
	Lit.	Gal.	Lit.	Gal.	mm	ins.	mm	ins.	mm	ins.	ins.	kg	lbs.
ST-20V-C	30	8.0	12.0	3.2	510	20 ¹ / ₁₆	305	12	273	10 ³ / ₄	¾ NPTF	19	41
ST-30V-C	53	14.0	33.9	8.96	491	19 ⁵ / ₁₆	419	16 ¹ / ₄	324	12 ³ / ₄	¾ NPTF	27	59
ST-42V-C	66	17.5	42.9	11.4	640	25 ³ / ₁₆	419	16 ¹ / ₄	324	12 ³ / ₄	¾ NPTF	32	71
ST-60V-C	95	25.0	42.9	11.4	864	34	419	16 ¹ / ₄	324	12 ³ / ₄	¾ NPTF	39	85
ST-70V-C	129	34.0	42.9	11.4	1076	42 ³ / ₈	419	16 ¹ / ₄	324	12 ³ / ₄	¾ NPTF	45	99
ST-80V-C	200	53.0	130	34	1029	40 ¹ / ₂	610	24	406	16	1 ¹ / ₄ NPTF	102	224
ST-120V-C	250	66	130	34	1213	47 ³ / ₄	610	24	406	16	1 ¹ / ₄ NPTF	121	266
ST-180V-C	292	77.0	130	34	1337	52 ⁵ / ₈	610	24	406	16	1 ¹ / ₄ NPTF	129	285
ST-210V-C	341	90.0	130	34	1524	60	610	24	406	16	1 ¹ / ₄ NPTF	145	319

Maximum Operating Conditions

Operating Temperature	200°F (93°C)
Working Pressure	150 PSIG (10.5 bar)

Specifications

Description	Standard Construction
Standard Factory Pre-charge	55 PSIG (3.9 bar)
System Connection	Stainless Steel
Diaphragm	Heavy Duty Butyl NSF/ANSI 61
Liner Material	Polypropylene
Shell	Steel
Finish	Red Oxide Primer

Constructed per ASME Code Section VIII, Division 1.

All dimensions and weights are approximate.

Complies with Low Lead Plumbing Law

Job Name _____
 Location _____

 Engineer _____

Contractor _____
 Contractor P.O. No. _____
 Sales Representative _____
 Model No. Ordered _____

THERM-X-TROL®

Thermal Expansion Absorbers, ST-C Series (ASME) 175 PSIG Working Pressure

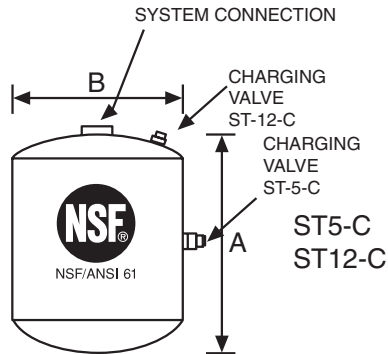

In-Line Models

Model No.	Tank Vol.		Max. Recomm. Accept. Vol.		A Vol Height		B Diameter		Sys. Conn.	Ship Wt.	
	Lit.	Gal	Lit.	Gal	mm	ins.	mm	ins.	ins.	kg	lbs.
ST-5-C	8	2.1	3.44	.9	264	10 ³ / ₈	254	10	¾ NPTF	9.5	21
ST-12-C	24	6.4	12.0	3.2	340	13 ³ / ₈	305	12	¾ NPTF	19	42

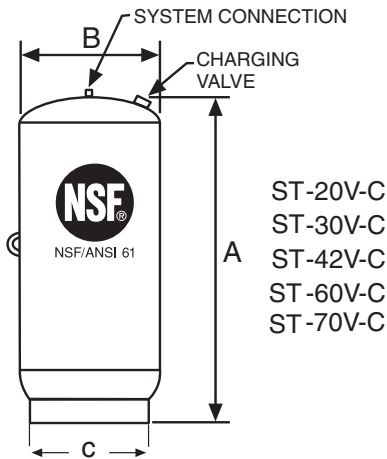

Stand Models

Model No.	Tank Vol.		Max. Recomm. Accept. Vol.		A Height		B Diameter		C Dim.		Sys. Conn.	Ship Wt.	
	Lit.	Gal	Lit.	Gal	mm	ins.	mm	ins.	mm	ins.	ins.	kg	lbs.
ST-20V-C	30	8.0	12.0	3.2	510	20 ¹ / ₁₆	305	12	273	10 ³ / ₄	¾ NPTF	23.6	52
ST-30V-C	53	14.0	33.9	8.96	491	19 ⁵ / ₁₆	419	16 ¹ / ₄	324	12 ³ / ₄	¾ NPTF	44	97
ST-42V-C	66	17.5	42.9	11.4	640	25 ³ / ₁₆	419	16 ¹ / ₄	324	12 ³ / ₄	¾ NPTF	52.7	116
ST-60V-C	95	25.0	42.9	11.4	864	34	419	16 ¹ / ₄	324	12 ³ / ₄	¾ NPTF	70	154
ST-70V-C	129	34.0	42.9	11.4	1076	42 ³ / ₈	419	16 ¹ / ₄	324	12 ³ / ₄	¾ NPTF	90	197
ST-80V-C	200	53.0	130	34	1029	40 ¹ / ₂	610	24	406	16	1 ¹ / ₄ NPTF	134	296
ST-120V-C	250	66.0	130	34	1213	47 ³ / ₄	610	24	406	16	1 ¹ / ₄ NPTF	127.6	281
ST-180V-C	292	77.0	130	34	1337	52 ⁵ / ₈	610	24	406	16	1 ¹ / ₄ NPTF	160.3	353
ST-210V-C	341	90.0	130	34	1524	60	610	24	406	16	1 ¹ / ₄ NPTF	173.4	382

Constructed per ASME Code Section VIII, Division 1.
All dimensions and weights are approximate.

Maximum Operating Conditions

Operating Temperature	200°F (93°C)
Working Pressure	175 PSIG (12.3 bar)

Specifications

Description	Standard Construction
Standard Factory Pre-charge	55 PSIG (3.9 bar)
System Connection	Stainless Steel
Diaphragm	Heavy Duty Butyl NSF/ANSI 61
Liner Material	Polypropylene
Shell	Steel
Coating	Red Oxide Primer

Complies with Low Lead Plumbing Law

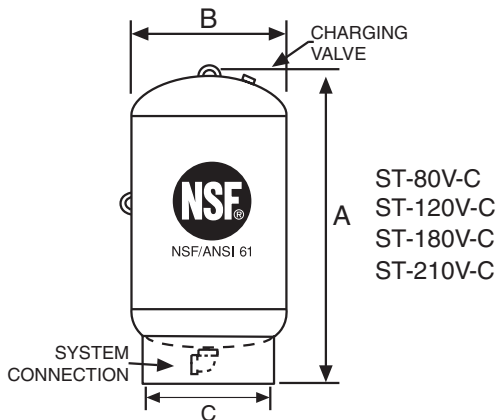

Job Name _____

Location _____

Engineer _____

Contractor _____

Contractor P.O. No. _____

Sales Representative _____

Model No. Ordered _____

THERM-X-TROL®

Thermal Expansion Absorbers, ST-C Series (ASME) 250 PSIG Working Pressure

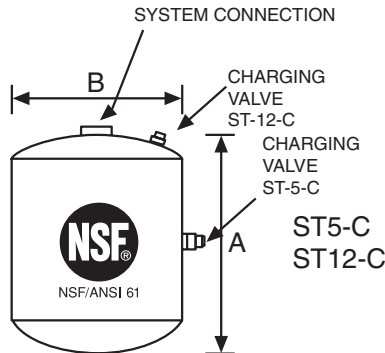

In-Line Models

Model No.	Tank Vol.		Max. Recomm. Accept. Vol.		A Vol Height		B Diameter		Sys. Conn.	Ship Wt.	
	Lit.	Gal	Lit.	Gal	mm	ins.	mm	ins.	ins.	kg	lbs.
ST-5-C	8	2.1	3.44	.9	264	10 ³ / ₈	254	10	¾ NPTF	9.5	21
ST-12-C	24	6.4	12.0	3.2	340	13 ³ / ₈	305	12	¾ NPTF	19	42

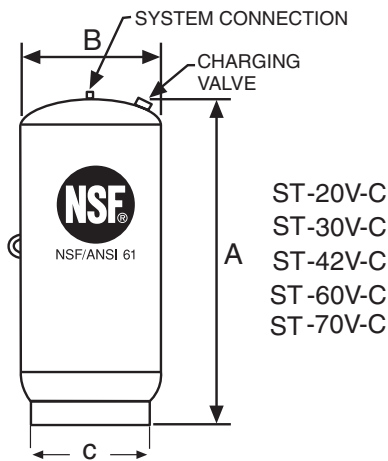

Stand Models

Model No.	Tank Vol.		Max. Recomm. Accept. Vol.		A Height		B Diameter		C Dim.		Sys. Conn.	Ship Wt.	
	Lit.	Gal	Lit.	Gal	mm	ins.	mm	ins.	mm	ins.	ins.	kg	lbs.
ST-20V-C	30	8.0	12.0	3.2	510	20 ¹ / ₁₆	305	12	273	10 ³ / ₄	¾ NPTF	23.6	52
ST-30V-C	53	14.0	33.9	8.96	491	19 ⁵ / ₁₆	419	16 ¹ / ₄	324	12 ³ / ₄	¾ NPTF	44	97
ST-42V-C	66	17.5	42.9	11.4	640	25 ³ / ₁₆	419	16 ¹ / ₄	324	12 ³ / ₄	¾ NPTF	52.7	116
ST-60V-C	95	25.0	42.9	11.4	864	34	419	16 ¹ / ₄	324	12 ³ / ₄	¾ NPTF	70	154
ST-70V-C	129	34.0	42.9	11.4	1076	42 ³ / ₈	419	16 ¹ / ₄	324	12 ³ / ₄	¾ NPTF	90	197
ST-80V-C	200	53.0	130	34	1029	40 ¹ / ₂	610	24	406	16	1 ¹ / ₄ NPTF	134	296
ST-120V-C	250	66.0	130	34	1213	47 ³ / ₄	610	24	406	16	1 ¹ / ₄ NPTF	127.6	281
ST-180V-C	292	77.0	130	34	1337	52 ⁵ / ₈	610	24	406	16	1 ¹ / ₄ NPTF	160.3	353
ST-210V-C	341	90.0	130	34	1524	60	610	24	406	16	1 ¹ / ₄ NPTF	173.4	382

Constructed per ASME Code Section VIII, Division 1. All dimensions and weights are approximate.

Maximum Operating Conditions

Operating Temperature	200°F (93°C)
Working Pressure	250 PSIG (17.6 bar)

Specifications

Description	Standard Construction
Standard Factory Pre-charge	55 PSIG (3.9 bar)
System Connection	Stainless Steel
Diaphragm	Heavy Duty Butyl NSF/ANSI 61
Liner Material	Polypropylene
Shell	Steel
Coating	Red Oxide Primer

Complies with Low Lead Plumbing Law

Job Name _____
 Location _____

 Engineer _____

Contractor _____
 Contractor P.O. No. _____
 Sales Representative _____
 Model No. Ordered _____

THERM-X-TROL®

Thermal Expansion Absorbers, ST-450 Series (ASME) 125 PSIG Working Pressure

Stand Models

Model No.	Tank Vol.		0 PSIG Acc. Vol.	Max. Recomm. Accept. Vol.		A Height		B Diameter		C Conn. Inset		D Conn. CenterLine		E Stand Diameter		Sys. Conn.	Ship Wt.	
	Lit.	Gal	Gal	Lit.	Gal	mm	ins.	mm	ins.	mm	ins.	mm	ins.	mm	ins.	ins.	kg	lbs.
ST-447-C	200	53	53	129	34	1150	45 ¹ / ₄	610	24	51	2	95	3 ³ / ₄	483	19	2	120	263
ST-448-C	300	80	80	197	52	1502	59 ¹ / ₈	610	24	51	2	95	3 ³ / ₄	483	19	2	140	308
ST-449-C	400	106	106	261	69	1857	73 ¹ / ₈	610	24	51	2	95	3 ³ / ₄	483	19	2	161	353
ST-450-C	500	132	132	322	85	2200	86 ⁵ / ₈	610	24	51	2	95	3 ³ / ₄	483	19	2	178	391
ST-451-C	600	158	158	386	102	1861	73 ¹ / ₄	762	30	89	3 ¹ / ₂	140	5 ¹ / ₂	608	24	2	230	508
ST-452-C	800	211	211	519	137	2317	91	762	30	89	3 ¹ / ₂	140	5 ¹ / ₂	608	24	2	345	760
ST-453-C	1000	264	264	647	171	2175	85 ⁵ / ₈	914	36	114	4 ¹ / ₂	178	7	763	30	3	368	810
ST-454-C	1200	317	317	780	206	2489	98	914	36	114	4 ¹ / ₂	178	7	763	30	3	415	914
ST-455-C	1400	370	370	908	240	2804	110 ³ / ₈	914	36	114	4 ¹ / ₂	178	7	763	30	3	462	1018
ST-456-C	1600	422	422	1037	274	2080	81 ¹ / ₈	1220	48	191	7 ¹ / ₂	181	7 ¹ / ₈	1063	42	3	750	1655
ST-457-C	2000	528	528	1298	343	2470	97 ¹ / ₄	1220	48	191	7 ¹ / ₂	181	7 ¹ / ₈	1063	42	3	873	1925

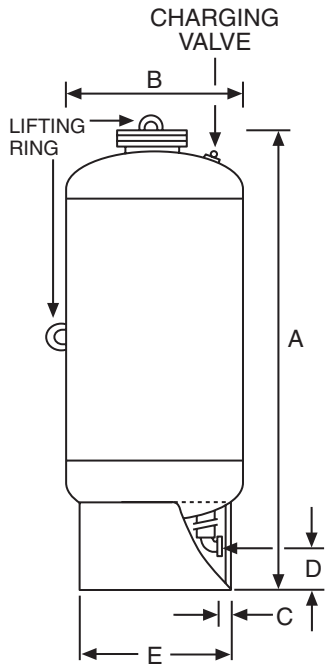

Maximum Operating Conditions

Operating Temperature	240°F (115°C)
Working Pressure	125 PSIG (8.8 bar)

Specifications

Description	Standard Construction
Standard Factory Pre-charge	55 PSIG (3.9 bar)
System Connection	Brass
Bladder	Heavy Duty Butyl NSF/ANSI 61
Bladder Thickness	.100 Ins. Minimum
Coating	Red Oxide Primer
Shell	Steel

Constructed per ASME Code Section VIII, Division 1.
 All dimensions and weights are approximate.
 Complies with Low Lead Plumbing Law

Job Name _____
 Location _____

 Engineer _____

Contractor _____
 Contractor P.O. No. _____
 Sales Representative _____
 Model No. Ordered _____
 ASME CERTIFICATION REQUIRED _____ Yes _____ No

THERM-X-TROL®

Thermal Expansion Absorbers, ST-450 Series (ASME) 150 PSIG Working Pressure

Stand Models

Model No.	Tank Vol.		0 PSIG Acc. Vol.	Max. Recomm. Accept. Vol.		A Height		B Diameter		C Conn. Inset		D Conn. Centerline		E Stand Diameter		Sys. Conn.	Ship Wt.	
	Lit.	Gal.	Gal.	Lit.	Gal.	mm	ins.	mm	ins.	mm	ins.	mm	ins.	mm	ins.	ins.	kg	lbs.
ST-447-C	200	53	53	129	34	1150	45 ¹ / ₄	610	24	51	2	95	3 ³ / ₄	483	19	2	120	263
ST-448-C	300	80	80	197	52	1502	59 ¹ / ₈	610	24	51	2	95	3 ³ / ₄	483	19	2	140	308
ST-449-C	400	106	106	261	69	1857	73 ¹ / ₈	610	24	51	2	95	3 ³ / ₄	483	19	2	161	353
ST-450-C	500	132	132	322	85	2200	86 ⁵ / ₈	610	24	51	2	95	3 ³ / ₄	483	19	2	178	391
ST-451-C	600	158	158	386	102	1861	73 ¹ / ₄	762	30	89	3 ¹ / ₂	140	5 ¹ / ₂	608	24	2	230	508
ST-452-C	800	211	211	519	137	2317	91	762	30	89	3 ¹ / ₂	140	5 ¹ / ₂	608	24	2	345	760
ST-453-C	1000	264	264	647	171	2175	85 ⁵ / ₈	914	36	114	4 ¹ / ₂	178	7	763	30	3	368	810
ST-454-C	1200	317	317	780	206	2489	98	914	36	114	4 ¹ / ₂	178	7	763	30	3	415	914
ST-455-C	1400	370	370	908	240	2804	110 ³ / ₈	914	36	114	4 ¹ / ₂	178	7	763	30	3	462	1018
ST-456-C	1600	422	422	1037	274	2080	81 ⁷ / ₈	1220	48	191	7 ¹ / ₂	181	7 ¹ / ₈	1063	42	3	750	1655
ST-457-C	2000	528	528	1298	343	2470	97 ¹ / ₄	1220	48	191	7 ¹ / ₂	181	7 ¹ / ₈	1063	42	3	873	1925

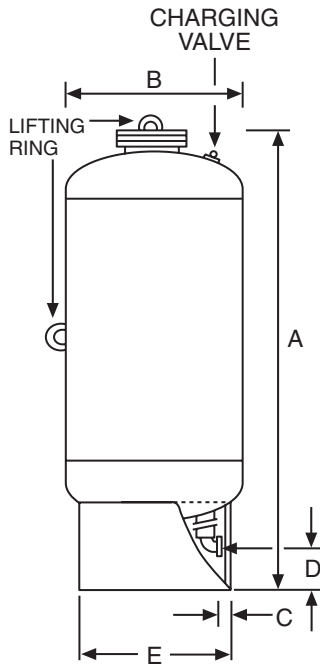

Maximum Operating Conditions

Operating Temperature	240°F (115°C)
Working Pressure	150 PSIG (10.5 bar)

Specifications

Description	Standard Construction
Standard Factory Pre-charge	55 PSIG (3.9 bar)
System Connection	Brass
Bladder	Heavy Duty Butyl NSF/ANSI 61
Bladder Thickness	.100 Ins. Minimum
Coating	Red Oxide Primer
Shell	Steel

Constructed per ASME Code Section VIII, Division 1.
 All dimensions and weights are approximate.
 Complies with Low Lead Plumbing Law

Job Name _____
 Location _____

 Engineer _____

Contractor _____
 Contractor P.O. No. _____
 Sales Representative _____
 Model No. Ordered _____
 ASME CERTIFICATION REQUIRED _____ Yes _____ No

THERM-X-TROL®

Pre-pressurized diaphragm-type well tanks

“ST” Series Bottom Connection Bladder Series (ASME) 150 PSIG Working Pressure

150 PSIG WP ASME Models

Model No.	Tank Volume		Accept Volume		A Height		B Diameter		Sys. Conn. ¹		Ship Weight	
	Lit.	Gal.	Lit.	Gal.	mm	ins.	mm	ins.	mm	ins.	kg	lbs.
ST-35-L	35	10	35	10	948	37 ¹ / ₁₆	254	10	25	1	29	65
ST-50-L	50	13	40	11	941	37 ¹ / ₁₆	305	12	25	1	33	72
ST-85-L	85	22	40	11	872	34 ⁵ / ₁₆	406	16	25	1	40	88
ST-100-L	100	26	40	11	991	39	406	16	25	1	43	94
ST-130-L	130	34	100	27	881	34 ¹ / ₁₆	508	20	25	1	59	130
ST-165-L	165	44	100	27	1008	39 ¹ / ₁₆	508	20	25	1	64	140
ST-200-L	200	53	100	27	1039	40 ⁷ / ₈	610	24	25	1	93	205
ST-300-L	300	80	100	27	1423	56	610	24	25	1	115	254
ST-400-L	400	106	200	53	1743	68 ⁵ / ₈	610	24	25	1	140	308
ST-500-L	500	132	200	53	2096	82 ¹ / ₂	610	24	25	1	160	352
ST-600-L	600	158	200	53	1702	67	762	30	25	1	200	442

¹System connection is NPTF

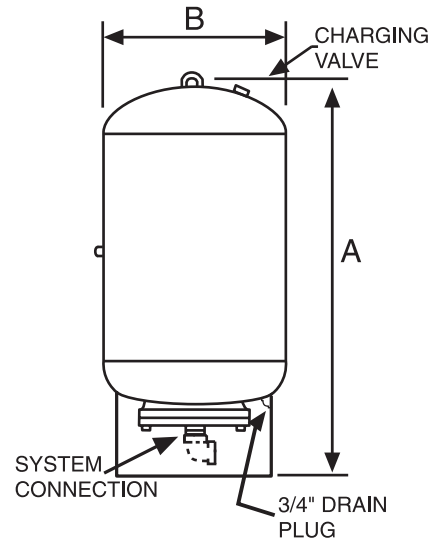

Maximum Operating Conditions

Operating Temperature	240°F (115°C)
Working Pressure	150 PSIG (10 bar)

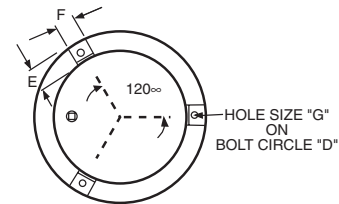

BOTTOM VIEW

Specifications

Description	Standard Construction
Shell	Carbon Steel
Bladder Material	Heavy Duty Butyl
Bladder Thickness (models 35-100)	.087 Ins. Minimum
Bladder Thickness (models 130-600)	.100 Ins. Minimum
System Connection	Stainless Steel
Coating	Red Oxide Primer
Factory Precharge	50 PSIG (3.4 bar)

Designed & constructed per ASME Section VIII, Division 1.

Optional Seismic Restraints

TANK Diam B	BOLT CIRCLE D	DIM. E	DIM. F	HOLE SIZE G
10	12 ⁵ / ₈	2	2	9 ¹ / ₁₆
12	14 ³ / ₄	2	2	9 ¹ / ₁₆
16	16 ³ / ₄	2	2	9 ¹ / ₁₆
20	16 ³ / ₄	2	2	9 ¹ / ₁₆
24	18	2	2	9 ¹ / ₁₆
30	22 ³ / ₄	3	3	3 ¹ / ₄

All dimensions and weights are approximate. Complies with Low Lead Plumbing Law

Job Name _____

Location _____

Engineer _____

Contractor _____

Contractor P.O. No. _____

Sales Representative _____

Model No. Ordered _____

System Pressure Range _____

Pre-Charge Pressure _____

Pump GPM _____

Date Submitted _____

THERM-X-TROL®

Pre-pressurized diaphragm-type well tanks

“ST” Series Bottom Connection Bladder Series (NON-ASME) 150 PSIG Working Pressure

150 PSIG WP NON-ASME Models

Model No.	Tank Volume		Accept Volume		A Height		B Diameter		Sys. Conn. ¹		Ship Weight	
	Lit.	Gal.	Lit.	Gal.	mm	ins.	mm	ins.	mm	ins.	kg	lbs.
ST-35-L	35	10	35	10	948	37 ¹ / ₁₆	254	10	25	1	29	65
ST-50-L	50	13	40	11	941	37 ¹ / ₁₆	305	12	25	1	33	72
ST-85-L	85	22	40	11	872	34 ⁵ / ₁₆	406	16	25	1	40	88
ST-100-L	100	26	40	11	991	39	406	16	25	1	43	94
ST-130-L	130	34	100	27	881	34 ¹ / ₁₆	508	20	25	1	59	130
ST-165-L	165	44	100	27	1008	39 ¹ / ₁₆	508	20	25	1	64	140
ST-200-L	200	53	100	27	1039	40 ⁷ / ₈	610	24	25	1	93	205
ST-300-L	300	80	100	27	1423	56	610	24	25	1	115	254
ST-400-L	400	106	200	53	1743	68 ⁵ / ₈	610	24	25	1	140	308
ST-500-L	500	132	200	53	2096	82 ¹ / ₂	610	24	25	1	160	352
ST-600-L	600	158	200	53	1702	67	762	30	25	1	200	442

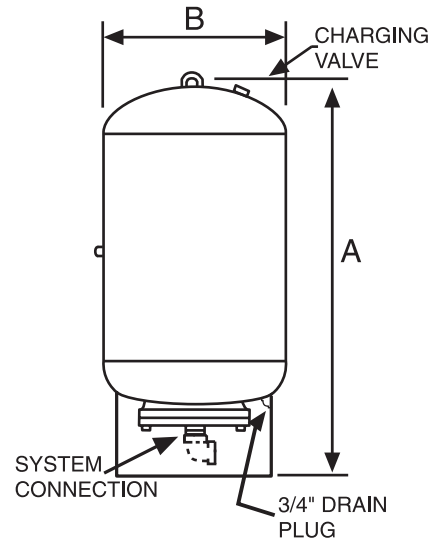

¹System connection is NPTF

Maximum Operating Conditions

Operating Temperature	240°F (115°C)
Working Pressure	150 PSIG (10 bar)

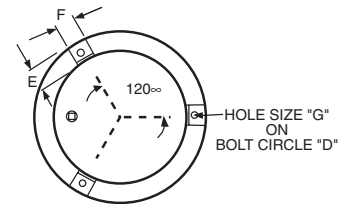

BOTTOM VIEW

Specifications

Description	Standard Construction
Shell	Carbon Steel
Bladder Material	Heavy Duty Butyl
Bladder Thickness (models 35-100)	.087 Ins. Minimum
Bladder Thickness (models 130-600)	.100 Ins. Minimum
System Connection	Stainless Steel
Coating	Red Oxide Primer
Factory Precharge	50 PSIG (3.4 bar)

Optional Seismic Restraints

TANK Diam B	BOLT CIRCLE D	DIM. E	DIM. F	HOLE SIZE G
10	12 ⁵ / ₈	2	2	9 ¹ / ₁₆
12	14 ³ / ₄	2	2	9 ¹ / ₁₆
16	16 ³ / ₄	2	2	9 ¹ / ₁₆
20	16 ³ / ₄	2	2	9 ¹ / ₁₆
24	18	2	2	9 ¹ / ₁₆
30	22 ³ / ₄	3	3	3 ¹ / ₄

Designed & constructed per ASME Section VIII, Division 1.

All dimensions and weights are approximate.
Complies with Low Lead Plumbing Law

Job Name _____

Location _____

Engineer _____

Contractor _____

Contractor P.O. No. _____

Sales Representative _____

Model No. Ordered _____

System Pressure Range _____

Pre-Charge Pressure _____

Pump GPM _____

Date Submitted _____

ASME CERTIFICATION REQUIRED _____ Yes _____ No