

Pipe Hangers

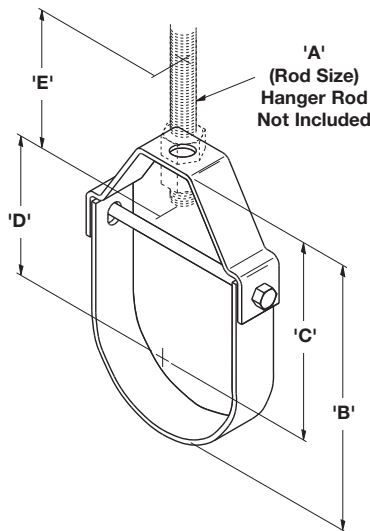

*Slide-Rite™ Clevis Hanger design, as shown above, for sizes 2, 2½, 3, 4, 5 & 6.

Pat. No. 5,848,770
5,924,655



- 'B'
Bottom of pipe
to top of hanger.
- 'C'
Center of pipe
to top of hanger.
- 'D'
Rod Take-Out
Center of pipe to
bottom of hanger rod.
- 'E'
Minimum thread
length of hanger rod
- 'F'
Adjustment
Top of cross bolt to
bottom of hanger rod nut
inside the hanger.

Material: Steel

Standard Finish: Plain, Electro-Plated, Dura-Green®, Hot-Dip Galvanized or Stainless Steel

Service: Designed for suspending non-insulated stationary pipe allowing for vertical adjustment.

Ordering: Specify part number and finish.

Approvals: Underwriter's Laboratories Listed for ¾" (20) thru 12" (300). Complies with Federal Specification WW-H-171E & A-A-1192A Type 1 and Manufacturers Standardization Society MSS SP-69 & SP-58 Type 1.

For AWWA - Ductile Iron, see B3102, page 44.

Note: When using oversized clevis hangers, install B3100PS (Pipe Sleeve) over cross bolt to prevent deformation of clevis bottom.

When attaching seismic bracing to clevis hangers, a B3100PS (Pipe Sleeve) must be installed over the cross bolt (see Seismic Restraints Brochure).

Order pipe sleeves B3100PS-(pipe size) separately.

Figure B3100 Standard Clevis Hanger

(Available with plastic coating as B3100C-size or felt lined as B3100F-Size)

Part No.	Nominal Pipe Size	Rod Size 'A'	'B'		'C'		
B3100-1/2	1/2"	(15)	3/8"-16	2 1/8"	(54.0)	1 11/16"	(42.9)
B3100-3/4	3/4"	(20)	3/8"-16	2 7/16"	(61.9)	1 7/8"	(47.6)
B3100-1	1"	(25)	3/8"-16	2 13/16"	(71.4)	2 1/8"	(54.0)
B3100-1 1/4	1 1/4"	(32)	3/8"-16	3 7/16"	(87.3)	2 9/16"	(65.1)
B3100-1 1/2	1 1/2"	(40)	3/8"-16	4"	(101.6)	3"	(76.2)
B3100-2 *	2"	(50)	3/8"-16	4 1/2"	(114.3)	3 1/4"	(82.5)
B3100-2 1/2 *	2 1/2"	(65)	1/2"-13	5 9/16"	(141.3)	4"	(101.6)
B3100-3 *	3"	(80)	1/2"-13	6 3/4"	(171.4)	4 7/8"	(123.8)
B3100-3 1/2	3 1/2"	(90)	1/2"-13	7"	(177.8)	5"	(127.0)
B3100-4 *	4"	(100)	5/8"-11	7 13/16"	(198.4)	5 1/2"	(139.7)
B3100-5 *	5"	(125)	5/8"-11	9 1/16"	(230.2)	6 1/8"	(155.6)
B3100-6 *	6"	(150)	3/4"-10	10 7/16"	(265.1)	6 15/16"	(176.2)
B3100-8	8"	(200)	3/4"-10	12 3/4"	(323.8)	8 3/8"	(212.7)
B3100-10	10"	(250)	7/8"-9	15 1/4"	(387.3)	9 13/16"	(249.2)
B3100-12	12"	300)	7/8"-9	17 5/8"	(447.7)	11 3/16"	(284.2)
B3100-14	14"	(350)	1"-8	19 9/16"	(496.9)	12 1/2"	(317.5)
B3100-16	16"	(400)	1"-8	21 7/16"	(544.5)	13 5/16"	(338.1)
B3100-18	18"	(450)	1"-8	25"	(635.0)	15 7/8"	(403.2)
B3100-20	20"	(500)	1 1/4"-7	27 1/2"	(698.5)	17 3/8"	(441.3)
B3100-24	24"	(600)	1 1/4"-7	31 3/4"	(806.4)	19 5/8"	(498.5)
B3100-30	30"	(750)	1 1/4"-7	38 7/8"	(987.3)	23 3/4"	(603.2)
B3100-36	36"	(900)	1 1/4"-7	46"	(1168.4)	27 13/16"	(706.4)

All dimensions in charts and on drawings are in inches. Dimensions shown in parentheses are in millimeters unless otherwise specified.

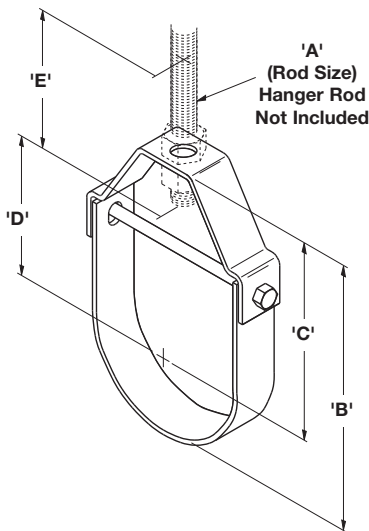

*Slide-Rite™ Clevis Hanger design, as shown above, for sizes 2, 2½, 3, 4, 5 & 6.

Pat. No. 5,848,770
5,924,655



- 'B'
Bottom of pipe to top of hanger.
- 'C'
Center of pipe to top of hanger.
- 'D'
Rod Take-Out
Center of pipe to bottom of hanger rod.
- 'E'
Minimum thread length of hanger rod
- 'F'
Adjustment
Top of cross bolt to bottom of hanger rod nut inside the hanger.

Slide-Rite™ Clevis Hanger Features

- Pipe will not 'pinch' when installing.
- 15° swing in either direction allows pipe to easily feed thru.
- Engineered design aligns bolt holes for quicker overhead installation.

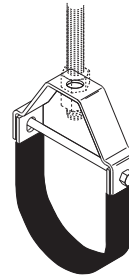

B3100C

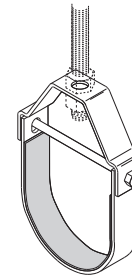

B3100F

Figure B3100 Standard Clevis Hanger (continued)

(Available with plastic coating as B3100C-size or felt lined as B3100F-Size)

Part No.	Rod Take-Out 'D'		'E'		Adjustment 'F'		Design Load		Wt./C	
	Lbs.	kN	Lbs.	kN	Lbs.	kN	Lbs.	kN	Lbs.	kg
B3100-1/2	15/16"	(23.8)	2 1/2"	(63.5)	7/16"	(11.1)	730	(3.25)	25	(11.3)
B3100-3/4	1 1/8"	(28.6)	2 1/2"	(63.5)	1/2"	(12.7)	730	(3.25)	29	(13.1)
B3100-1	1 3/8"	(34.9)	2 1/2"	(63.5)	5/8"	(15.9)	730	(3.25)	35	(15.9)
B3100-1 1/4	1 13/16"	(46.0)	2 1/2"	(63.5)	7/8"	(22.2)	730	(3.25)	40	(18.1)
B3100-1 1/2	2 1/4"	(57.1)	2 1/2"	(63.5)	1 3/16"	(30.2)	730	(3.25)	42	(19.0)
B3100-2 *	2 1/2"	(63.5)	2 1/2"	(63.5)	1 5/8"	(41.3)	730	(3.25)	52	(23.6)
B3100-2 1/2 *	3 1/16"	(77.8)	2 1/2"	(63.5)	2"	(50.8)	1350	(6.00)	90	(40.8)
B3100-3 *	3 15/16"	(100.0)	2 1/2"	(63.5)	2"	(50.8)	1350	(6.00)	110	(49.9)
B3100-3 1/2	4 1/16"	(103.2)	2 1/2"	(63.5)	2"	(50.8)	1350	(6.00)	142	(64.4)
B3100-4 *	4 3/8"	(111.1)	2 1/2"	(63.5)	2"	(50.8)	1430	(6.36)	132	(59.9)
B3100-5 *	5"	(127.0)	2 1/2"	(63.5)	2"	(50.8)	1430	(6.36)	215	(97.5)
B3100-6 *	5 11/16"	(144.5)	3"	(76.2)	2"	(50.8)	1940	(8.63)	320	(145.1)
B3100-8	7 1/8"	(181.0)	3 1/2"	(88.9)	2 5/16"	(58.7)	2000	(8.89)	485	(220.0)
B3100-10	8 3/8"	(212.7)	3 1/2"	(88.9)	2 5/16"	(58.7)	3600	(16.01)	846	(383.7)
B3100-12	9 11/16"	(246.1)	3 1/2"	(88.9)	2 5/8"	(66.7)	3800	(16.90)	1083	(491.2)
B3100-14	10 5/8"	(269.9)	4"	(101.6)	2 7/8"	(73.0)	4200	(18.68)	1432	(649.5)
B3100-16	11 9/16"	(293.7)	4"	(101.6)	2 11/16"	(68.3)	4600	(20.46)	2200	(997.9)
B3100-18	14 3/16"	(360.3)	4 1/2"	(114.3)	3 15/16"	(100.0)	4800	(21.35)	2500	(1134.0)
B3100-20	16 5/8"	(422.3)	5"	(127.0)	5 3/8"	(136.5)	4800	(21.35)	4400	(1995.8)
B3100-24	18 5/8"	(473.1)	5"	(127.0)	5 3/8"	(136.5)	4800	(21.35)	5000	(2268.0)
B3100-30	22 3/4"	(577.8)	5"	(127.0)	6 1/4"	(158.7)	6000	(26.69)	6600	(2993.7)
B3100-36	25"	(635.0)	5"	(127.0)	5 7/16"	(138.1)	6000	(26.69)	8474	(3843.8)

All dimensions in charts and on drawings are in inches. Dimensions shown in parentheses are in millimeters unless otherwise specified.