

AVAILABLE
OUTLET SIZES: 2", 3", 4", 5", 6"

OUTLET SIZE _____

CUSTOMER APPROVAL _____

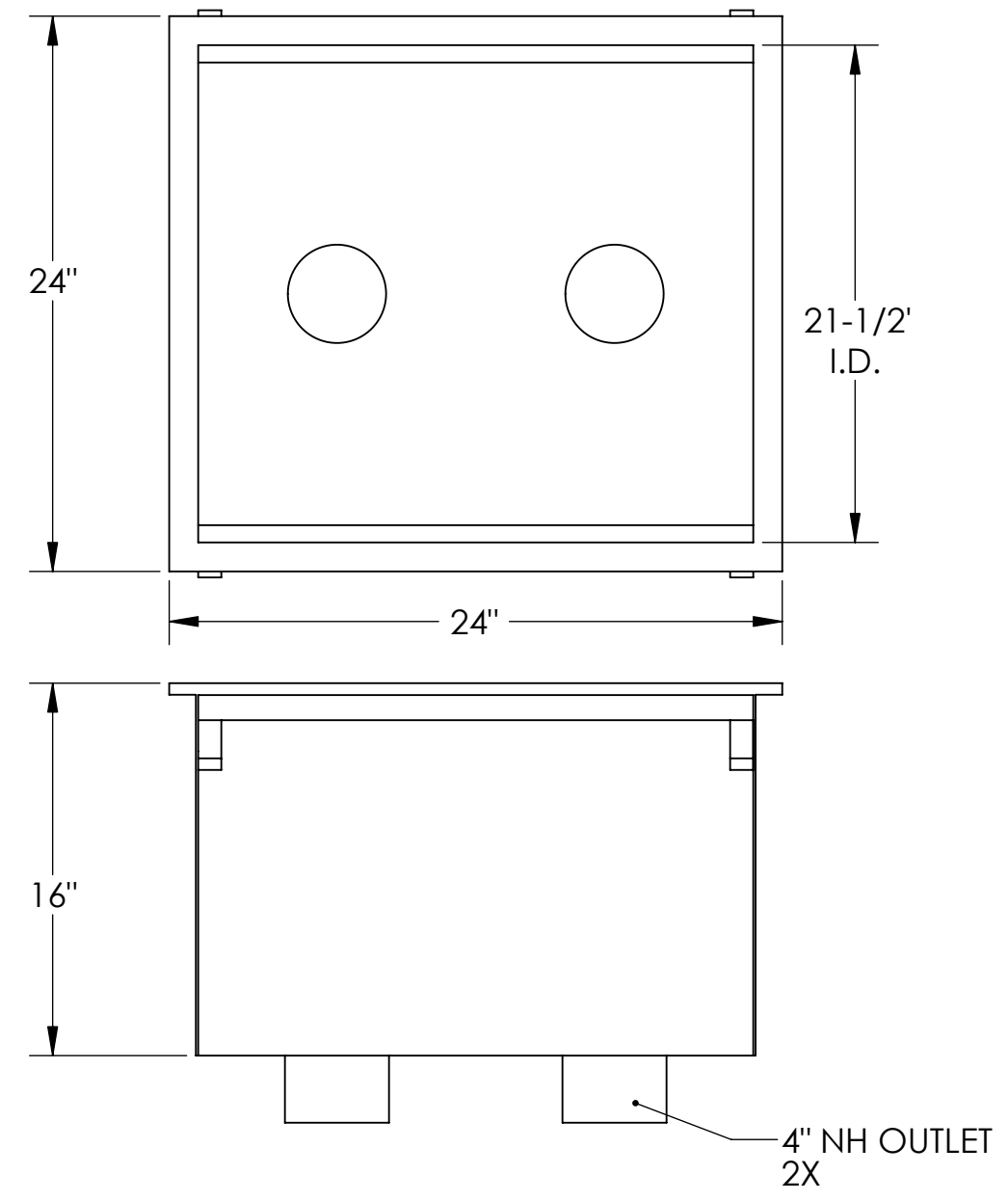
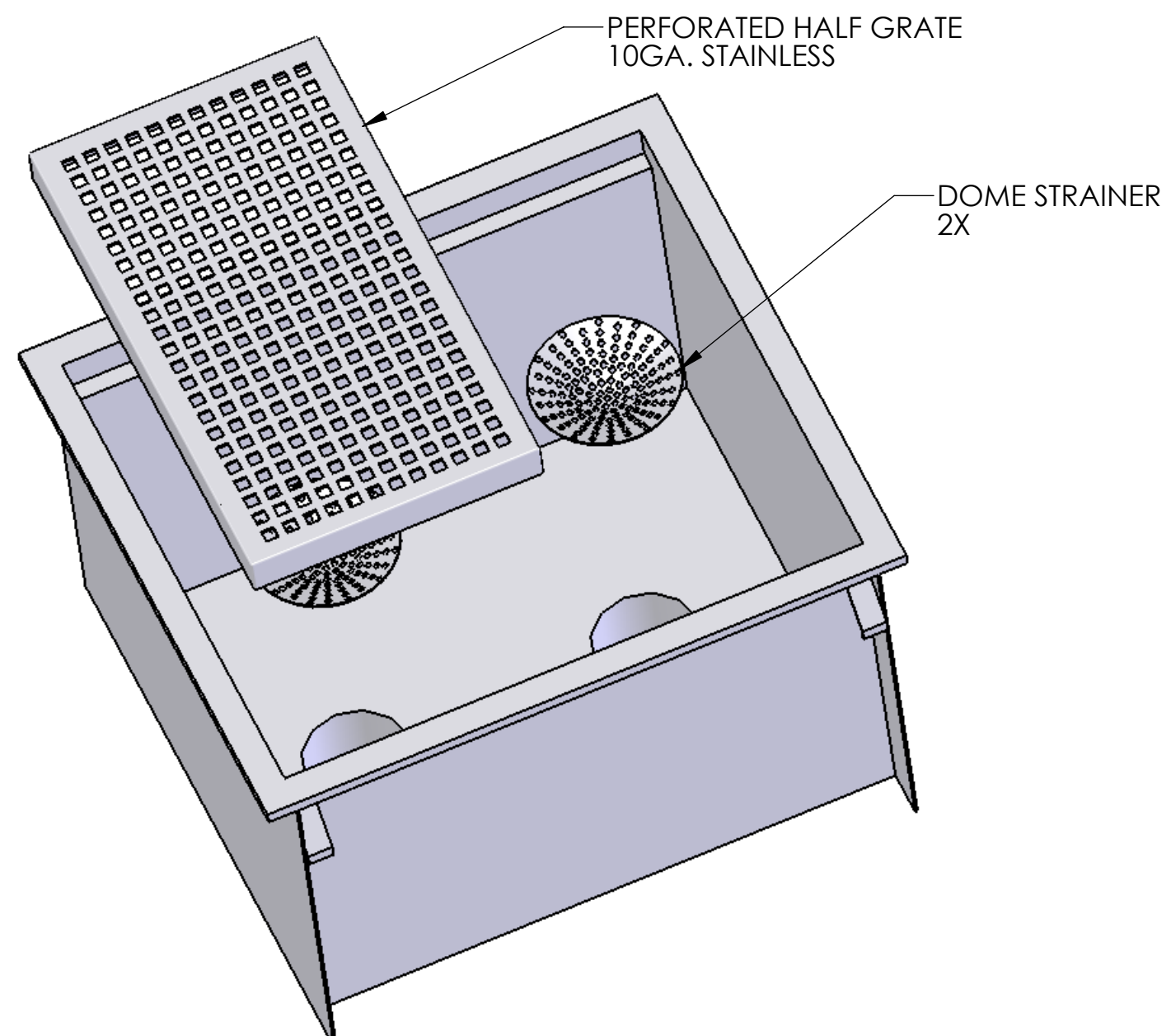

***** ALL DIMENSIONS ARE NOMINAL DIMENSIONS
AND ARE SUBJECT TO CHANGE*****

StainlessDrains.com
888.785.2345

PROPRIETARY AND CONFIDENTIAL
THE INFORMATION CONTAINED IN THIS
DRAWING IS THE SOLE PROPERTY OF
THE MANUFACTURER INC. ANY
REPRODUCTION IN PART OR AS A WHOLE
WITHOUT THE WRITTEN PERMISSION OF
THE MANUFACTURER INC IS
PROHIBITED.

		UNLESS OTHERWISE SPECIFIED:		NAME	DATE
		DIMENSIONS ARE IN INCHES	DRAWN	AM	
		TOLERANCES:	CHECKED	SD	
		FRACTIONAL ±	ENG APPR.		
		ANGULAR: MACH ± BEND ±	MFG APPR.		
		TWO PLACE DECIMAL ±	Q.A.		
		THREE PLACE DECIMAL ±	COMMENTS:		
		INTERPRET GEOMETRIC TOLERANCING PER:			
		MATERIAL			
NEXT ASSY	USED ON	FINISH			
APPLICATION		DO NOT SCALE DRAWING			
StainlessDrains.com a division of the Henry Group					
P. O. Box 1278 Greenville, TX 75403 Toll Free 888-785-2345					
TITLE: CSDSUMP24X24X16-1/2P					
SIZE B	DWG. NO.				REV