

STANDARD

MODEL 100

COMBINATION TUB/SHOWER



**NOMINAL DIMENSIONS:**

60"W x 34"D x 77"H

Target Weight: 152 ± 10 lbs.

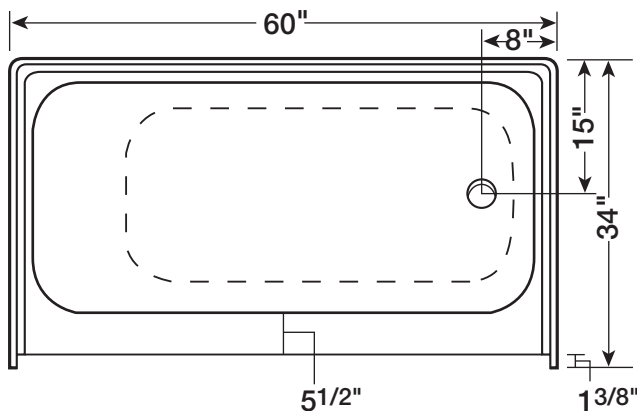

**STANDARD FEATURES**

This Standard, 44-gallon combination tub/shower features a clean, simple design with soap and shampoo ledges at tub level in both corners.

The backrest is gently sloped for maximum comfort when reclining in tub. Tub includes an anti-slip floor for added safety (Meets ASTM-462). A unique composite support plate is laminated to the bottom for added strength eliminating "flex" or "sponging". Select Right- or Left-hand plumbing.

**OPTIONAL FEATURES**

- Factory-installed hydro-massage spa package
- Factory-installed through-bolted curtain rod
- Factory-installed and pre-plumbed pressure-balancing mixing valve
- Additional factory-installed through-bolted flangeless grab bar(s)
- Tempered glass enclosures
- Wide selection of contemporary colors

**Model 100**

