

Gas Ball Valve

GB1A Female x Female, Lever Handle

- CSA Certified to ½ PSI for indoor appliance connections per ANSI Z21.15/CSA 9.1
- 5 PSI for indoor shutoff per CGA CR91-002 and ASME B16.44
- 600 PSI CWP Rated

MATERIAL LIST

PART	SPECIFICATION
1. Body	Forged Brass ¹ CU>57%
2. End Piece	Forged Brass ¹ CU>57%
3. Seat	PTFE, Glass Reinforced
4. Ball	Brass, Chrome Plated
5. Stem	Brass
6. O-Ring	Nitrile
7. Handle	Aluminum, Painted Red
8. Nut	Steel, Plated
9. ID Plate	Aluminum

DIMENSIONS—WEIGHT

Size (In.)	A	B	C	D	E	Wgt
¾	1.91	1.14	1.19	0.39	0.51	.31
½	2.21	1.19	1.19	0.47	0.61	.36
¾	2.45	1.26	1.19	0.59	0.67	.47
1	2.76	1.36	1.19	0.75	0.71	.91

Note: ¹ For Material Certification, contact NIBCO Technical Services.



GB1A

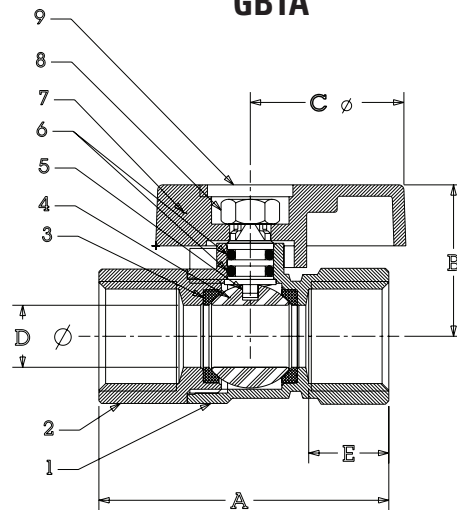

GB2A Female x Female, Square Head

- CSA Certified to ½ PSI for indoor appliance connections per ANSI Z21.15/CSA 9.1
- 5 PSI for indoor shutoff per CGA CR91-002 and ASME B16.44
- 600 PSI CWP Rated

MATERIAL LIST

PART	SPECIFICATION
1. Body	Forged Brass ¹ CU>57%
2. End Piece	Forged Brass ¹ CU>55%
3. Seat	PTFE, Glass Reinforced
4. Ball	Brass, Chrome Plated
5. Stem	Brass
6. O-Ring	Nitrile
7. Handle	Copper Alloy Painted Red
8. Screw	Steel, plated

DIMENSIONS—WEIGHT

Size (In.)	A	B	C	D	E	Wgt
½	2.21	1.44	.95	.47	.61	.34
¾	2.45	1.56	.95	.59	.67	.45

Note: ¹ For Material Certification, contact NIBCO Technical Services.



GB2A

