

"8911"

1/2" - 3"

**BRASS BALL VALVE
TWO PIECE, FULL PORT
600 PSIG WOG / 150 PSIG SWP *
SOLDERED ENDS**

FED. SPEC. WW-V-35C II, BZ, 3, c
MSS SP-110
ASME A112.4.14



ANSI / NSF 61
BALL VALVE
9EAO

WATER QUALITY

MATERIALS LIST

ITEM	PART	MATERIALS	ASTM/SPEC
1	Body	Brass, Forged	B283
2	Tailpiece	Brass, Forged	B283
3	Ball	CP Brass Ball	B283
4	Ball Seal	PTFE	Commercial
5	Stem	Brass	B124
6	O-Ring	Buna-N	D2006
7	Thrust Washer	PTFE	Commercial
8	Gland Nut	Brass	B124
9	Packing	PTFE	Commercial
10	Handle	Zinc Plated Steel	Commercial
11	Handle Nut	Zinc Plated Steel	Commercial

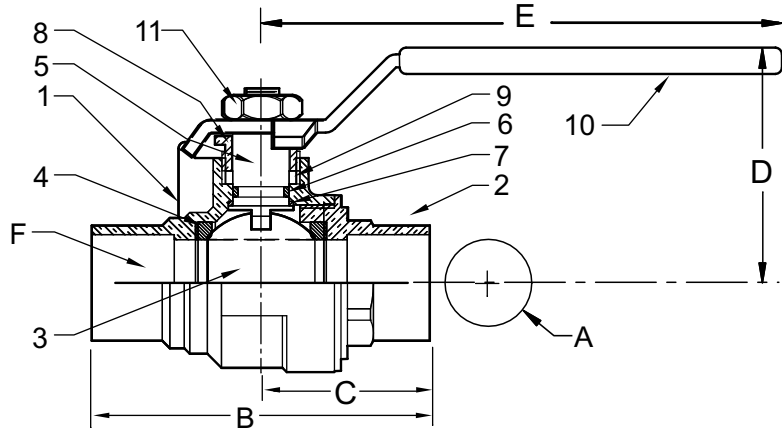

PRESSURE - TEMPERATURE CHART

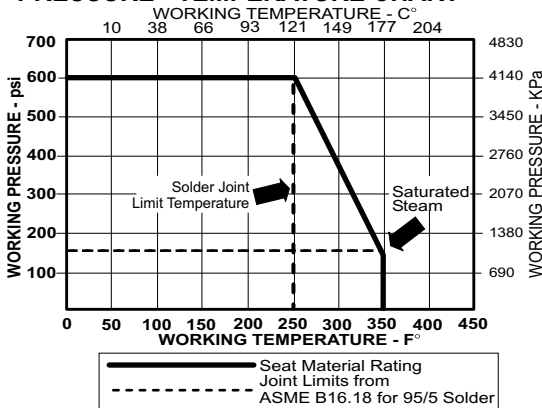

VACUUM SERVICE TO 29 INCHES Hg.

Valve Size	UNITS	1/2"	3/4"	1"	1-1/4"	1-1/2"	2"	2-1/2"	3"
A	INCHES	.50	.76	1.00	1.26	1.50	2.00	2.48	2.95
	mm	12.7	19.3	25.0	32.0	38.1	51.0	63.0	74.9
B	INCHES	2.28	3.1	3.56	4.13	4.64	5.75	7.25	8.25
	mm	58	79	90	105	118	146	131.1	152.4
C	INCHES	1.14	1.55	1.78	2.06	2.32	2.87	3.62	4.12
	mm	29	39	45	52	59	73	92.1	104.7
D	INCHES	1.46	1.93	2.10	2.33	2.52	2.96	3.94	4.37
	mm	37	49	53	59	64	75	100.1	111.0
E	INCHES	3.14	4.35	4.35	5.00	5.00	6.90	7.87	7.87
	mm	80	110	110	127	127	175	199.9	199.9
F	TUBE SIZE	.63	.88	1.13	1.38	1.63	2.13	2.63	3.13
Cv		18	40	72	112	161	287	448	645
TORQUE	in-lb	19	58	69	89	124	210	445	563
	N.m	2.1	6.5	7.8	10	14	24		
WEIGHT	lbs	0.40	0.82	1.15	1.53	2.23	4.61	10.00	13.00
	Kg	.180	.370	.521	.696	1.012	2.092	4.54	5.90

Rev. 3

The information presented on this sheet is correct at the time of publication. Hammond Valve reserves the right to change design, and/or material specifications without notice. For the Installation, Operation and Maintenance Manual (IOM) see the engineering section on our website. For the most current information access www.hammondvalve.com

