

CHECK IB940

HORIZONTAL SWING – BRONZE

125 lb. SWP-200 lb. WOG† • General Service
Teflon Disc • Threaded Ends

SPECIFICATIONS

IB946	Conforms to: MSS SP-80. Type 4, Class 150, Threaded Ends.
--------------	--

MATERIAL LIST

NO.	PART	MATERIAL	SPECIFICATION
1	Body	Bronze	ASTM B 62
2	Cap	Bronze	ASTM B 62
3	Lever	Bronze	Commercial
4	Disc	Teflon	
5	Disc Holder	Bronze	ASTM B 16 1/4" and 3/4" Incl. ASTM B 62 1" to 2" Incl.
6	Pin	St. Steel	Commercial
7	Plug (not shown)	Bronze	ASTM B 16
8	Retaining Ring	St. Steel	Commercial
9	Disc Nut	Bronze	Commercial

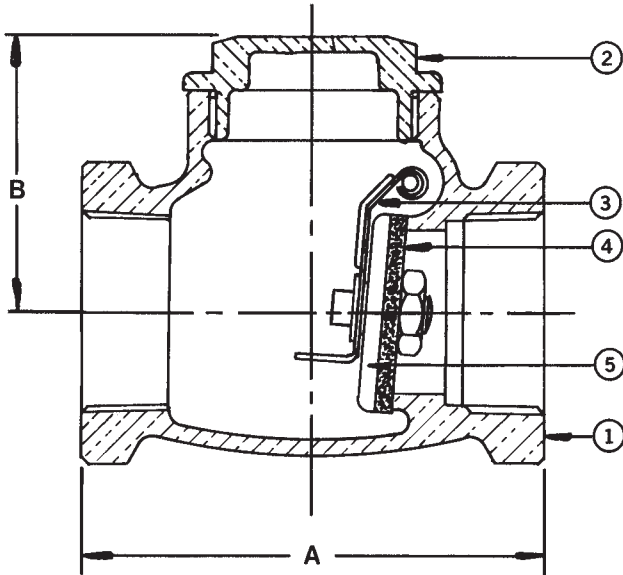

DIMENSIONS - INCHES / MILLIMETERS				
UNITS	SIZE	A	B	C _v
Inches	1/4	2.13	1.44	3.3
mm	6.35	53.98	36.53	
Inches	3/8	2.13	1.44	6.0
mm	9.53	53.98	36.53	
Inches	1/2	2.31	1.44	10.0
mm	12.70	58.75	36.53	
Inches	3/4	2.63	1.69	18.0
mm	19.05	66.68	42.88	
Inches	1	3.25	2.00	31.0
mm	25.40	82.55	50.80	
Inches	1 1/4	3.56	2.13	54.0
mm	31.75	90.50	53.98	
Inches	1 1/2	4.00	2.38	76.0
mm	38.10	101.60	60.33	
Inches	2	4.75	2.81	131.0
mm	50.80	130.18	207.98	

† Non-Shock

Rev. 3

BETTER AT EVERY TURN



HAMMONDVALVE
www.hammondvalve.com

The information presented on this sheet is correct at the time of publication. Hammond Valve reserves the right to change design, and/or material specifications without notice. For the Installation, Operation and Maintenance Manual (IOM) see the engineering section on our website. For the most current information access www.hammondvalve.com