

CHECK IR1124

HORIZONTAL SWING – IRON

125 lb. SWP-200 lb. WOG† • Bolted Cap • Flanged Ends

These iron body check valves may be installed in both horizontal and vertical lines with upward flow or in any intermediate position.

Flange shape and drilling to specification ASME B 16.1 (125 lb.)

MATERIAL LIST

NO.	PART	MATERIAL	SPECIFICATION
1	Bolt	Steel	
2	Identification Plate	Aluminum	
3	Bonnet	Cast Iron	ASTM A126, Class B
4	Body Gasket	Non-Asbestos	
5	Nut	Steel	
6	Side Plug	Brass	ASTM B16
7	Gasket	Non-Asbestos	
8	Hanger Pin	Brass	ASTM B16
9	Hanger	Ductile Iron	ASTM A536
10 ¹	Disc	Cast Iron	ASTM A126, Class B
11	Washer	Steel	
12	Cotter Pin	Carbon Steel Galvanized	
13	Seat Ring	Bronze	ASTM B62
14	Disc Nut	Steel	ASTM A307
15	Body	Cast Iron	ASTM A126, Class B
16	Stud Bolt	Brass	ASTM B16

¹ Valve Disc - Cast iron with bronze disc face rings.

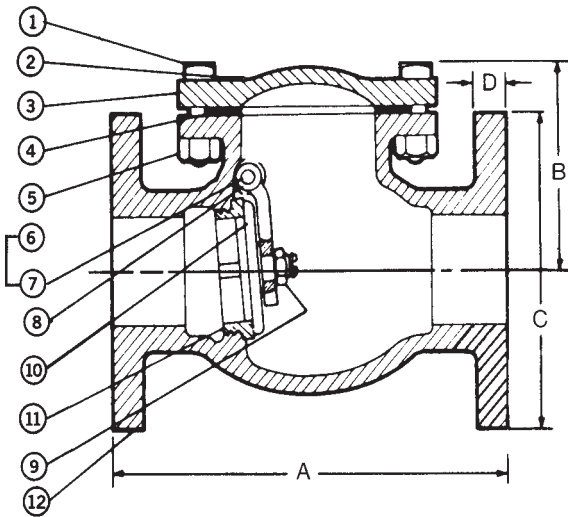

DIMENSIONS - INCHES / MILLIMETERS

UNITS	SIZE	A	B	C	D	C _v
Inches	2	8.00	3.94	6.00	0.63	137
mm	50.80	203.20	100.03	152.40	15.88	
Inches	2 1/2	8.50	4.50	7.00	0.69	221
mm	63.50	215.90	114.30	177.80	17.48	
Inches	3	9.50	5.13	7.50	0.75	327
mm	76.20	241.30	130.18	190.50	19.05	
Inches	4	11.50	6.13	9.00	0.94	605
mm	101.60	292.10	155.58	228.60	23.83	
Inches	5	13.00	6.81	10.00	0.94	975
mm	127.00	330.20	173.05	254.00	23.83	
Inches	6	14.00	8.00	11.00	1.00	1440
mm	152.40	355.60	203.20	279.40	25.40	
Inches	8	19.50	9.44	13.50	1.13	2670
mm	203.20	495.30	239.73	342.90	28.58	
Inches	10	24.50	12.06	16.00	1.19	4300
mm	254.00	622.30	306.40	406.40	30.18	
Inches	12	27.50	16.13	19.00	1.25	6350
mm	304.80	698.50	409.58	482.60	31.75	

† Non-Shock

Rev. 2

BETTER AT EVERY TURN



HAMMONDVALVE
www.hammondvalve.com

The information presented on this sheet is correct at the time of publication. Hammond Valve reserves the right to change design, and/or material specifications without notice. For the Installation, Operation and Maintenance Manual (IOM) see the engineering section on our website. For the most current information access www.hammondvalve.com