

APPENDIX B: Strength Design Performance values in accordance to 2006 IBC

ITW RED HEAD TRUBOLT WEDGE ANCHOR

DESIGN INFORMATION TESTED TO ICC-ES AC193 AND ACI 355, IN ACCORDANCE WITH 2006 IBC

Trubolt®
Wedge Anchors

TRUBOLT WEDGE ANCHOR DESIGN INFORMATION^{1,2,3}

DESIGN INFORMATION	Symbol	Units	Nominal Anchor Diameter									
			1/4		3/8		1/2		5/8		3/4	
Anchor O.D.	d_o	in	0.250		0.375		0.500		0.625		0.750	
Effective embedment	h_{ef}	in	1-1/2	2	1-3/4	2-5/8	1-7/8	3-3/8	2-1/2	4	3-1/2	4-3/4
Minimum member thickness	h_{min}	in	4	4	4	5	5	6	5	8	6	8
Critical edge distance	c_{ac}	in	2-5/8	3	2-5/8	5-1/4	3-3/4	6-3/4	5	8	7	9
Minimum edge distance	c_{min}	in	1-3/4	1-1/2	2-1/4	2	3-3/4	3-3/4	4-1/4	3-1/4	3-3/4	3-1/2
Minimum anchor spacing	s_{min}	in	1-3/4	1-1/2	2-1/4	2	3-3/4	3-3/4	4-1/4	3-1/4	3-3/4	3-1/2
Min. Specified Yield Strength	f_y	lb/in ²	55,000									
Min. Specified Ultimate Strength	f_{uta}	lb/in ²	75,000									
Effective tensile stress area	A_{se}	in ²	0.032		0.078		0.142		0.226		0.334	
Steel strength in tension	N_s	lb	2,385		5,815		10,645		16,950		25,050	
Steel strength in shear	V_s	lb	1,430		2,975	3,490	4,450	6,385	6,045	10,170	10,990	15,030
Pullout strength, uncracked concrete	$N_{p,uncr}$	lb	1,392	1,706	2,198	3,469	2,400	4,168	4,155	6,638	8,031	10,561
Anchor Category (All anchors are ductile)			1									
Effectiveness factor k_{uncr} , uncracked concrete			24									
Axial stiffness in service load range	β	lb/in	14,651	9,385	17,515	26,424	32,483	26,136	42,899	21,749	43,576	28,697
Coefficient for variation for axial stiffness in service load range			34	47	28	45	17	33	55	22	63	28
Strength reduction factor ϕ for tension, steel failure modes			0.75									
Strength reduction factor ϕ for shear, steel failure modes			0.65									
Strength reduction factor ϕ for tension, concrete failure modes, Condition B			0.65									
Strength reduction factor ϕ for shear, concrete failure modes, Condition B			0.70									

¹ Trubolt+ Anchor Design Strengths must be determined in accordance with ACI 318-05 Appendix D and this table

² The Trubolt+ Wedge Anchor is a ductile steel element as defined by ACI 318 D.1

³ 1/4", 3/8", & 1/2" diameter data is listed in ICC-ES ESR-2251.

Trubolt®
Wedge Anchors

TRUBOLT WEDGE ANCHOR (INSTALLED)

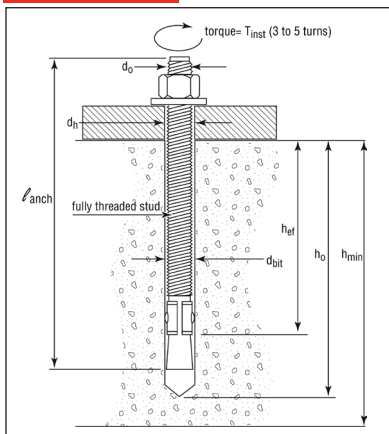

TRUBOLT WEDGE INSTALLATION INFORMATION

	Symbol	Units	Nominal Anchor Diameter (in.)									
			1/4		3/8		1/2		5/8		3/4	
Anchor outer diameter	d_o	in	0.25		0.375		0.5		0.625		0.750	
Nominal carbide bit diameter	d_{bit}	in	1/4		3/8		1/2		5/8		3/4	
Effective embedment depth	h_{ef}	in	1-1/2	2	1-3/4	2-5/8	1-7/8	3-3/8	2-1/2	4	3-1/2	4-3/4
Min hole depth	h_o	in	2	2-1/2	2-1/2	3-3/8	2-3/4	4-1/4	3-3/4	5-1/4	4-3/4	6
Min slab thickness	h_{min}	in	4	4	5	5	6	5	8	6	8	8
Installation torque	T_{inst}	ft-lb	4		25		55		90		110	
Min hole diameter	d_h	in	5/16		7/16		9/16		11/16		13/16	

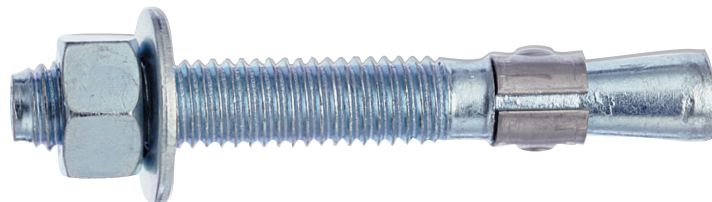

ITW Red Head®

Call our toll free number 800-899-7890 or visit our web site for the most current product and technical information at www.itwredhead.com

RED HEAD®

APPENDIX B: Strength Design Performance values in accordance to 2006 IBC



TRUBOLT WEDGE PULLOUT STRENGTH (N_p, unc) (POUNDS)¹

Nominal Anchor Diameter (in.)	Effective Embedment Depth (in.)	Concrete Compressive Strength			
		f'c = 2,500 psi	f'c = 3,000 psi	f'c = 4,000 psi	f'c = 6,500 psi
1/4	1-1/2	1,392	1,525	1,610	1,822
	2	1,706	1,869	1,947	2,151
3/8	1-3/4	2,198	2,408	2,621	3,153
	2-5/8	3,469	3,800	3,936	4,275
1/2	1-7/8	2,400	2,629	3,172	4,520
	3-3/8	4,168	4,520	4,520	4,520
5/8	2-1/2	4,155	4,155	4,376	5,578
	4	6,638	6,900	7,968	10,157
3/4	3-1/2	8,031	8,322	9,610	12,251
	4-3/4	10,561	10,561	10,561	12,251

For SI: 1 inch = 25.4 mm, 1 lbf = 4.45 N, 1 psi = 0.006895 Mpa

¹ Values are for single anchors with no edge distance or spacing reduction.

TRUBOLT WEDGE ANCHOR ALLOWABLE STATIC TENSION (ASD), NORMAL-WEIGHT UNCRACKED CONCRETE¹⁻⁶

Nominal Anchor Diameter (in.)	Effective Embedment Depth (in.)	Concrete Compressive Strength			
		f'c = 2,500 psi	f'c = 3,000 psi	f'c = 4,000 psi	f'c = 6,500 psi
1/4	1-1/2	611	670	707	800
	2	749	821	855	945
3/8	1-3/4	965	1,058	1,151	1,385
	2-5/8	1,524	1,669	1,729	1,878
1/2	1-7/8	1,054	1,155	1,393	1,985
	3-3/8	1,831	1,985	1,985	1,985
5/8	2-1/2	1,825	1,825	1,922	2,450
	4	2,915	3,030	3,499	4,461
3/4	3-1/2	3,527	3,655	4,221	5,381
	4-3/4	4,638	4,638	4,638	5,381

For SI: 1 inch = 25.4 mm, 1 lbf = 4.45 N, 1 psi = 0.006895 Mpa

Design Assumptions:

- ¹ Single anchor with static tension load only.
- ² Concrete determined to remain uncracked for the life of the anchorage.
- ³ Load combinations from 2006 IBC, Sections 1605.2.1 and 1605.3.1 (no seismic loading).
- ⁴ Thirty percent dead load and 70 percent live load, controlling load combination 1.2D + 1.6L
- ⁵ Calculation of weighted average: 1.2D + 1.6L = 1.2 (0.3) + 1.6 (0.7) = 1.48
- ⁶ Values do not include edge distance or spacing reductions.



TRUBOLT WEDGE ANCHOR ALLOWABLE STATIC SHEAR (ASD), STEEL (POUNDS)¹⁻⁵

Nominal Anchor Diameter (in.)	Effective Embedment Depth (in.)	Allowable Steel Capacity, Static Shear
1/4	1-1/2	628
	2	
3/8	1-3/4	1,307
	2-5/8	1,533
1/2	1-7/8	1,954
	3-3/8	2,804
5/8	2-1/2	2,655
	4	4,467
3/4	3-1/2	4,827
	4-3/4	6,601

For SI: 1 inch = 25.4 mm, 1 lbf = 4.45 N, 1 psi = 0.006895 Mpa

Design Assumptions:

- ¹ Single anchor with static shear load only.
- ³ Load combinations from 2006 IBC, Sections 1605.2.1 and 1605.3.1 (no seismic loading).
- ³ Thirty percent dead load and 70 percent live load, controlling load combination 1.2D + 1.6L
- ⁴ Calculation of weighted average: 1.2D + 1.6L = 1.2 (0.3) + 1.6 (0.7) = 1.48
- ⁵ Values do not include edge distance or spacing reductions.