

Fiberglas® All Service Duct Wrap

Thermal Conductivity

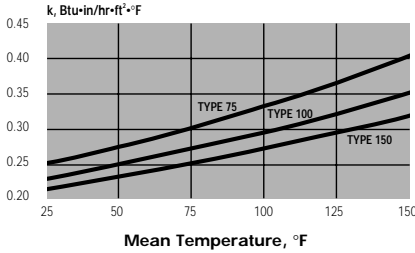

Apparent thermal conductivity curve determined in accordance with ASTM Practice C 1045 with data obtained by ASTM Test Method C 177. Values are nominal, subject to normal testing and manufacturing tolerances.

Condensation Control

To determine thickness to prevent condensation at various ambient temperature and humidity levels, based on installed thickness 75% of nominal (out-of-package) thickness, 55°F (13°C) air duct internal temperature:

1. Select maximum expected relative humidity (R.H.) on the lower scale.
2. Move up vertically until that line intersects the expected maximum ambient air temperature.
3. Select the thickness indicated by the intersection point.

Nominal Duct Wrap Thickness to Prevent Surface Condensation

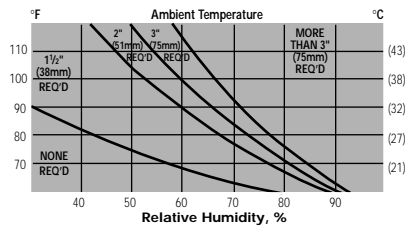

The above chart is based on indoor conditions so far as wind and other factors are concerned

Limitations

Fiberglas All-Service Duct Wrap is not recommended for use on duct systems subject to continuous service at temperatures in excess of 250°F (121°C). It should not be used in conditions where condensation might occur on the FRK facing nor exposed to weathering or mechanical abuse without proper protection. It should not be used on the inside of ducts.

Physical Property Data

Property	Test Method	Value
Operating temperature	ASTM C 411	250°F (121°C)
Insulation jacket temperature limit	ASTM C 1136	150°F (66°C)
Water vapor permeance	ASTM E 96	0.02 perms
Water vapor sorption	ASTM C 1104	<3% by weight at 120°F (49°C), 95% R.H.
Fungi resistance	ASTM C 1338	Meets requirements
Thermal conductivity k at 75°F mean, Btu•in/hr•ft²•°F (λ at 24°C mean, W/m•°C)	ASTM C 518	Type 75 0.30 (0.043) Type 100 0.27 (0.039) Type 150 0.25 (0.036)
Surface burning characteristics	ASTM E 84*	Flame spread: 25* Smoke developed: 50

* The surface burning characteristics of these products have been determined in accordance with ASTM E 84. This standard should be used to measure and describe the properties of materials, products or assemblies in response to heat and flame under controlled laboratory conditions and should not be used to describe or appraise the fire hazard or fire risk of materials, products or assemblies under actual fire conditions. However, results of this test may be used as elements of a fire risk assessment which takes into account all of the factors which are pertinent to an assessment of the fire hazard of a particular end use. Values are reported to the nearest 5 rating.

Application Recommendations

Before applying Fiberglas All-Service Duct Wrap, ducts shall be clean, dry and tightly sealed at all joints and seams. Fiberglas All-Service Duct Wrap shall be cut to "stretch-out" dimensions and a 2" (50mm) (approx.) piece of duct wrap removed from the facing at the end of the piece of duct wrap to form an overlapping staple and tape flap, as shown below.

Install duct wrap tightly butted with facing outside. Overlap 2" (50mm) formed tape flap and facing at other end of piece of duct wrap. If ducts are rectangular or square, install so insulation is not excessively compressed at duct corners. Seams shall be stapled 6" (150 mm) (approx.) on center with outward clinching staples. Adjacent sections of duct wrap shall be tightly butted with the 2" (50mm) tape flap overlapping.

Seal all seams and joints with pressure-sensitive tape matching the facing (either plain foil or FRK backing stock) or glass fabric and mastic. Cloth duct tape of any color and finish using reclaimed rubber adhesives is not recommended for use on Fiberglas All-Service Duct Wrap.

Where rectangular ducts are 24" (600mm) in width or greater, duct wrap shall be additionally secured to the bottom of the duct with mechanical fasteners such as pins and speed clip washers, spaced on 18" (425mm) centers (maximum) to prevent sagging of insulation. It is neither necessary nor desirable to adhere duct wrap to duct surfaces.

Where a vapor retarder is required, seal all tears, punctures and other penetrations of the duct wrap facing using one of the above methods to provide a vapor-tight system.

Material Requirements to Achieve Installed R-Value

Nominal Thickness, in. (mm)	Installed Thickness, in. (mm)	Stretch-Out Dimensions, in. (mm)		
		Round and Oval Ducts	Square Ducts	Rectangular Ducts
1 1/2 (38)	1 1/8 (29)	P+9 1/2 (240)	P+8 (205)	P+7 (180)
2 (51)	1 1/2 (38)	P+12 (305)	P+10 (255)	P+8 (205)
2.2 (56)	1 5/8 (41)	P+13 (330)	P+11 (280)	P+8 1/2 (215)
3 (76)	2 1/4 (57)	P+17 (430)	P+14 1/2 (370)	P+11 1/2 (290)

P = measured duct perimeter



SYSTEM THINKING
Makes the Difference™

OWENS CORNING WORLD HEADQUARTERS
ONE OWENS CORNING PARKWAY
TOLEDO, OHIO, USA 43659

System Thinking™ and System Thinking Makes the Difference™ are trademarks of Owens Corning. Fiberglas® is a registered trademark of Owens Corning.

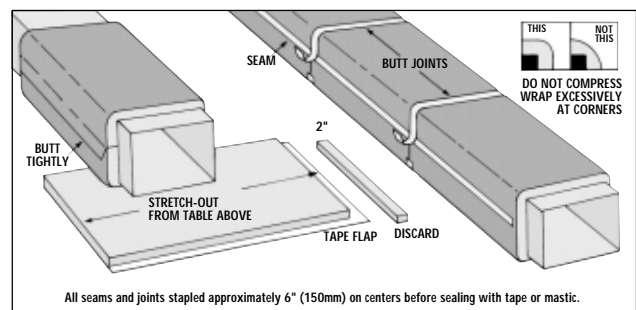



- | | |
|---|--|
| <input type="checkbox"/> TYPE 75 | <input type="checkbox"/> TYPE 100 |
| 1½" (38 mm) | 1½" (38 mm) |
| 2" (51 mm) | 2" (51 mm) |
| 2½" (56 mm) | <input type="checkbox"/> TYPE 150 |
| 3" (76 mm) | 1½" (38 mm) |
| | 2" (51 mm) |

The installed R-value is based on installation of product over sealed sheet metal ductwork with the average installed thickness at 75% of nominal thickness and thermal conductivity (k) at the installed compressed density.

Description

Fiberglas® All-Service Duct Wrap is a blanket of glass fiber insulation factory-laminated to FRK vapor retarder facing. A 2" (50mm) stapling and taping flange is provided on one edge. This product is designed to meet existing performance standards such as NFPA 90A and 90B and other model building and energy codes.

Uses

Fiberglas All-Service Duct Wrap is used for external insulation of commercial and residential heating, air conditioning and dual-temperature ducts operating at temperatures from 40°F (4°C) to 250°F (121°C). This insulation, when applied in accordance with installation instructions, will provide the "installed R-value" as published for the product and printed on the facing, assuring specified in-place thermal performance and condensation control.

Recommended Thickness

Owens Corning recommends a minimum thickness of 2" (51 mm) for protection against excessive heat loss or gain. Selection of insulation thickness and application of insulation are the responsibility of the engineer and contractor.

Features/Benefits

Assured Thermal Performance

When installed in accordance with instructions so that compression is controlled, Fiberglas All-Service Duct Wrap provides specified thermal performance. See R-value table below. Operating costs are controlled due to reduction of heat loss or gain through duct walls.

Condensation Control

Fiberglas All-Service Duct Wrap helps control moisture condensation on the ductwork as well as on the outer vapor retarder jacket. This helps maintain insulation efficiency and reduces the likelihood of stained ceilings due to moisture damage.

Enhanced Comfort Control

Fiberglas All-Service Duct Wrap helps heating and cooling systems to deliver conditioned air to occupied spaces at or near design temperatures. By conserving heating and cooling energy, HVAC systems may operate under reduced load.

Meets Model Energy and Mechanical Codes

Fiberglas All-Service Duct Wrap, when correctly installed, complies with model energy codes and standards including ASHRAE 90.1 and 90.2. Architects, contractors, code officials and owners are assured of compliance and "no-problem" inspection.

Availability and Installed R-Values

Availability and Installed R-Values. Standard roll width: 48" (1.2m)

Installed R (RSI) values: When installed in accordance with recommended installation procedures, Fiberglas All-Service Duct Wrap will provide installed R (RSI) values as follows:

Nominal Thickness, in. (mm)	Out-of-Package R (RSI) Value*	Installed Thickness**, in. (mm)	Installed R (RSI) Value*
TYPE 75 - 0.75 pcf (12 kg/m³)			
1½ (38)	5.0 (0.88)	1⅝ (29)	4.2 (0.74)
2 (51)	6.7 (1.18)	1½ (38)	5.6 (0.99)
2.2 (56)	7.4 (1.30)	1⅝ (41)	6.0 (1.06)
3 (76)	10.0 (1.76)	2¼ (57)	8.3 (1.46)
TYPE 100 - 1.00 pcf (16 kg/m³)			
1½ (38)	5.6 (0.99)	1⅝ (29)	4.5 (0.79)
2 (51)	7.4 (1.30)	1½ (38)	6.0 (1.06)
TYPE 150 - 1.50 pcf (24 kg/m³)			
1½ (38)	6.0 (1.06)	1⅝ (29)	4.8 (0.85)
2 (51)	8.0 (1.41)	1½ (38)	6.4 (1.13)

*hr•ft²•°F/Btu (m²•°C/W) at 75°F (24°C) mean temperature. **Assumes 25% compression of insulation.

Specification Compliance

- ASTM C 1290, Flexible Fibrous Glass Blanket Insulation Used to Externally Insulate HVAC Ducts, Type III
- ASTM C 1136, Flexible Low Permeance Vapor Retarders for Thermal Insulation, Type II (facing only)
- ASTM C 553,* Mineral Fiber Thermal Insulation: Type I - Fiberglas All-Service Duct Wrap Type 75; Type II - Fiberglas All-Service Duct Wrap Types 100 and 150. (Operating temperatures to 250°F (121°C) and thermal values to 150°F (66°C) (mean).

* Preferred specification is ASTM C 1290.

NOTE TO SPECIFIERS - Federal Specification HH-I-558B (Amendment 3), Form B (covering the duct wrap), and Federal Specification HH-B-100B (covering the facing), are obsolete. These are replaced by the above referenced ASTM specifications.

Flexible and Easy to Install

Fiberglas All-Service Duct Wrap is easily cut and fit to flat, curved or irregular duct surfaces for a neat, thermally effective insulation blanket. Because it's easier to install than rigid boards, installation costs are lowered.

Facings

Manufacturers of facing materials used in Owens Corning All-Service Duct Wrap are required to certify that their products meet the physical property requirements of ASTM C 1136, flexible low permeance vapor retarders for thermal insulation, Type II, when the surface burning characteristics are determined in accordance with ASTM E 84.* Test results to verify this conformance are furnished to Owens Corning by the manufacturer of the facing material.

* The surface burning characteristics of these products have been determined in accordance with ASTM E 84. This standard should be used to measure and describe the properties of materials, products or assemblies in response to heat and flame under controlled laboratory conditions and should not be used to describe or appraise the fire hazard or fire risk of materials, products or assemblies under actual fire conditions. However, results of this test may be used as elements of a fire risk assessment which takes into account all of the factors which are pertinent to an assessment of the fire hazard of a particular end use. Values are reported to the nearest 5 rating.