

L



JAY R. SMITH MFG. CO.
 DIVISION OF SMITH INDUSTRIES, INC.
 POST OFFICE BOX 3237
 MONTGOMERY, ALABAMA 36109-0237 (USA)
 TEL: 334-277-8520 FAX: 334-272-7396 www.jrsmith.com



MEMBER OF:

LOCATION

LARGE GENERAL PURPOSE ROOF DRAINS

LOW PROFILE DOME

FUNCTION: Used in flat roof of any construction. Large low profile dome provides sufficient free area for quick drainage of rain water and protects the drain sump and connected piping from the intrusion of debris. Wide clamping surface holds flashing and roofing materials without puncturing.

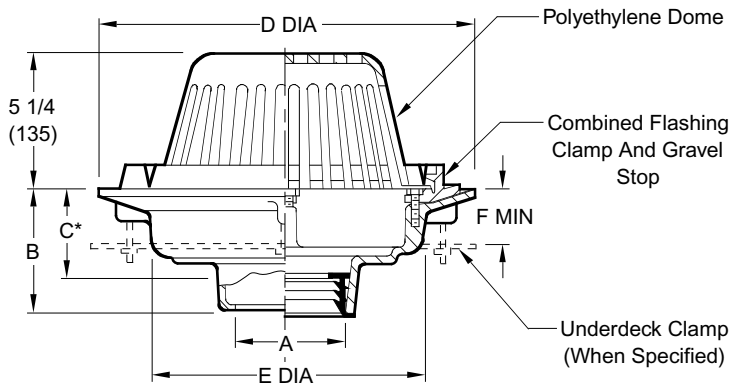

- Fig. 1010C ...CAULK OUTLET
- Fig. 1010Y ...NO-HUB OUTLET

*This Dimension to Internal Stop of Speedi-Set Gasket.
 **NOTE: Required for regularly furnished 08" (205) outlet body with 20" (510) DIA flange.

recommended deck opening

outlet size	with suffix-R	less suffix-R
02(50),03(75),04(100)	17(430) DIA	14(355) DIA
05(125),06(150)		
08(200)	**21(535) DIA	18 3/4(475) DIA

A SIZE	B (BOTTOM OUTLET)					SIDE OUTLET			FREE AREA SQ IN (SQ CM)	
	CAULK, NO-HUB, & SPEEDI-SET	THREADED	C	D DIA	E DIA	F MIN	G	H		J
02(50),03(75),	5	3 3/4	3 3/4	15 1/4	11	1 1/8	4 3/4	6	7 3/4	102.5
04(100)	(125)	(95)	(95)	(390)	(280)	(29)	(120)	(150)	(195)	(661)
05(125),	5	3 3/4	3 3/4	15 1/4	11	1 1/8	6 1/4	6 7/8	7 3/4	102.5
06(150)	(125)	(95)	(95)	(390)	(280)	(29)	(160)	(175)	(195)	(661)
08(200),	7 3/4	7 3/4	-	20	16	1 5/8	6 1/4	6 7/8	7 3/4	158
10(250)	(195)	(195)	-	(510)	(405)	(41)	(160)	(175)	(195)	(1019)

REGULARLY FURNISHED:

Duco Cast Iron Body with Combined Flashing Clamp and Gravel Stop with Polyethylene Dome.

VARIATIONS:

- Expansion Joint (Specify Fig.1710) (Fig. 1010 only)
- Extension (Specify Height) -E
- "L" Shaped Underdeck Clamp -CL
- L Speedi-Set Service Weight 02(50), 03(75), and 04(100)" sizes only (Fig. 1010 Only)
- LXH Speedi-Set Extra Heavy 02(50), 03(75), and 04(100)" sizes only (Fig. 1010 only)
- NO-HUB Adaptor (Specify Fig. 2646Y) (Fig. 1020 only)
- Secondary Flashing Clamp -C2
- Sump Receiver -R
- Underdeck Clamp -C
- Vandal Proof Dome -U
- T Threaded Outlet

NOTE: Dimensions shown in parentheses are in millimeters.

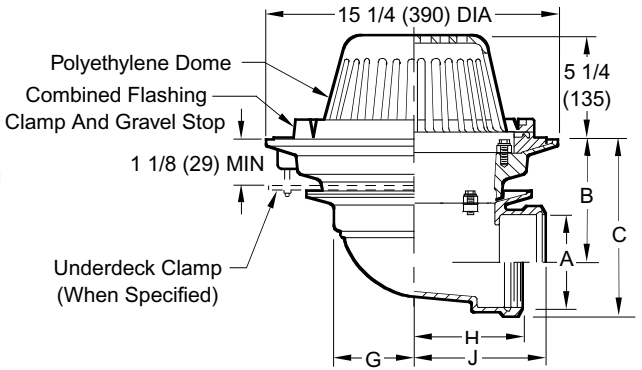

- Fig. 1020C 02(50), 03(75) & 04(100)" CAULK OUTLET
- Fig. 1020T 02(50), 03(75) & 04(100)" THREADED OUTLET

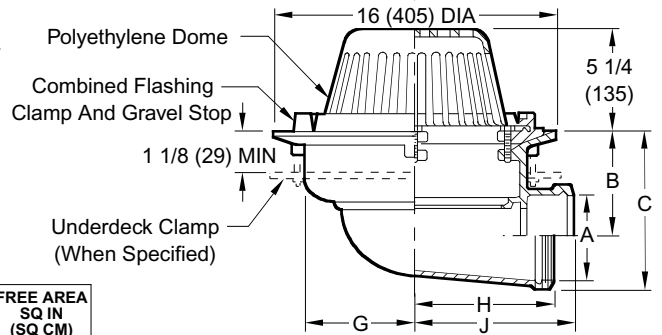

- Fig. 1020C 05(125) & 06"(150) CAULK OUTLET
- Fig. 1020T 05(125) & 06"(150) THREADED OUTLET

(SIDE OUTLET)

A SIZE	02 (50)	03 (75)	04 (100)	05 (125)	06 (150)
B	6 7/8 (175)	6 3/8 (162)	5 7/8 (149)	5 (125)	4 1/2 (115)
C	8 5/8 (219)	8 3/4 (220)	8 3/4 (220)	8 1/2 (215)	8 1/2 (215)

OPTIONAL MATERIALS:

- All Aluminum -AA (Fig. 1010 only)
- Aluminum Dome -AD
- Cast Iron Dome -CID
- Galvanized Cast Iron Dome -CIDG
- Galvanized Cast Iron Body & Collar -G
- Rough Bronze Dome -RBD
- Stainless Steel (Specify Fig. 9780)

1010, 1020

DRAWING NUMBER S1010

SIZE A

SCALE: NONE

DATE: 5-24-85

APPROVED BY: TD

CHECKED BY: TD

DRAWN BY: CR

FIGURE NUMBER

REV.	DATE	DESCRIPTION	BY	CKD. BY
L	5-26-99	Revised and ch'g Opt. Mat.	CMD	BS
K	6-12-95	Added Millimeters	EMB	BS
J	6-23-94	Revised	EMB	BS
H	4-7-93	Submittal Update	EMB	BS
G	10-20-92	Revised Chart	TWK	BS

WEIGHT POUNDS	VOLUME CUBIC FEET	FIGURE NUMBER
		1010, 1020

DIMENSIONS ARE SUBJECT TO MANUFACTURERS TOLERANCE AND CHANGE WITHOUT NOTICE

WE CAN ASSUME NO RESPONSIBILITY FOR USE OF SUPERSEDED OR VOID DATA