



**JAY R. SMITH MFG. CO.**  
 DIVISION OF SMITH INDUSTRIES, INC.  
 POST OFFICE BOX 3237  
 MONTGOMERY, ALABAMA 36109-0237 (USA)  
 TEL: 334-277-8520 FAX: 334-272-7396 www.jrsmith.com



LOCATION

## COMPACT FIXTURE SUPPORTS WITH VERTICAL OFFSET FITTINGS FOR SIPHON JET WATER CLOSETS

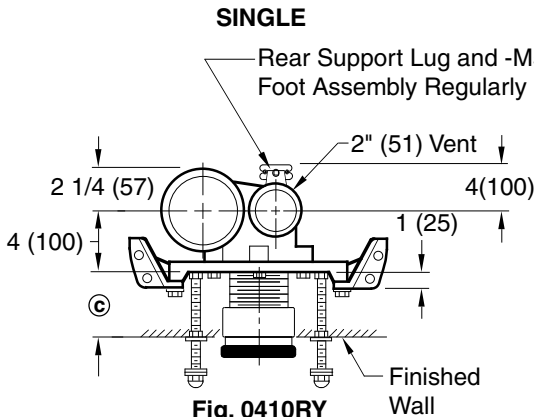

**Fig. 0410RY  
 Top View**

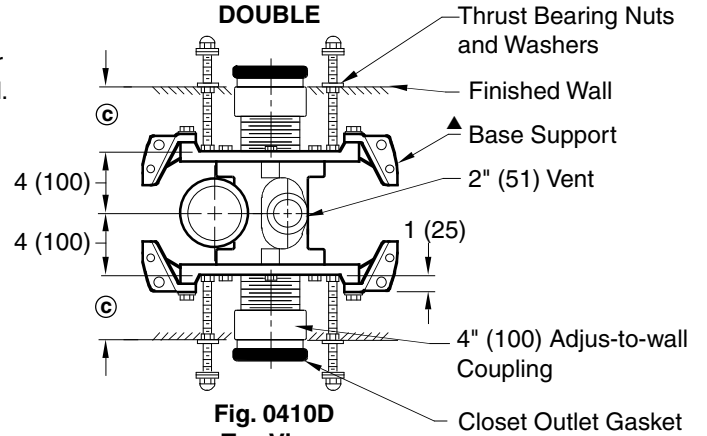

**Fig. 0410D  
 Top View**

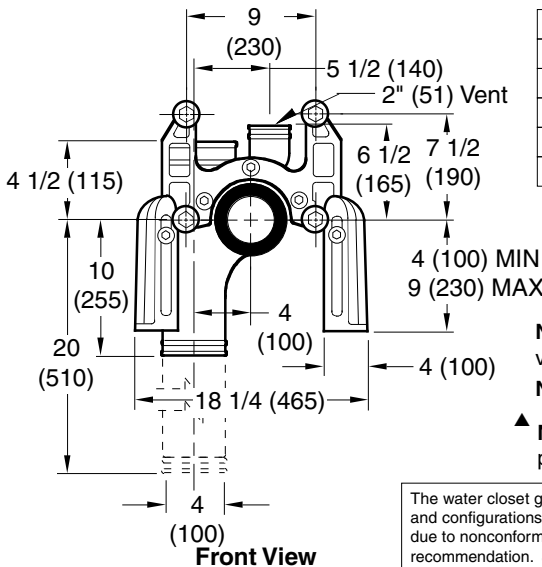

**Front View**

- Fig. 0410LY . . . . NO-HUB Left Hand
- Fig. 0410RY . . . . NO-HUB Right Hand
- Fig. 0417LY . . . . NO-HUB L.H. Long Barrel
- Fig. 0417RY . . . . NO-HUB R.H. Long Barrel
- Fig. 0410DY . . . . NO-HUB Double
- Fig. 0417DY . . . . NO-HUB Double Long Barrel

**NOTE:** Dimensions shown in parentheses are in millimeters.

**NOTE:** See reverse side for recommended setting of closet outlet connection and various modifications.

**NOTE:** When used with concealed flush valve locate face plate behind supply pipe.

**NOTE:** Base support must be securely anchored to floor (with four 1/2" (13) bolts provided by contractor).

The water closet gasket regularly furnished is made of molded neoprene and designed to fit water closet outlet dimensions and configurations shown in ANSI Standard A112.19.2M-1995, Figure 13B. If gasket is not found to be compatible to fixture due to nonconformance of said fixture to ANSI A112.19.2M, then fixture manufacturer shall be consulted for a suitable gasket recommendation. Jay R. Smith assumes no liability for connections to fixtures which do not conform to these standards.

**© DIMENSION - ADJUS-TO-WALL  
 TYPE OUTLET CONNECTION**

The Smith Adjus-to-Wall outlet connection provides adjustment at the face of the wall at the time the fixture is set; thus, compensating for wall construction variations. The © dimension is measured from the front of the face plate to the finished wall. To properly determine the length of nipple required, deduct 1" (25) from the © dimension. The Adjus-to-Wall coupling will provide 1/2" (13) horizontal adjustment in either direction with the coupling extended 5/16" (8) past face of the finished wall.

© dimension = 4" (100) (regularly furnished) consisting of nipple and Adjus-to-Wall coupling permitting adjustment from 3" (76) min. to 4" (100) max.

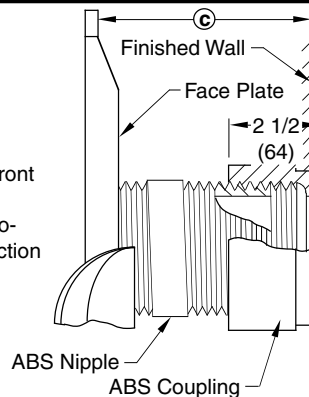

**NIPPLE LENGTHS AVAILABLE**

LENGTH	MIN	©	MAX
2 1/2 (64)	2 1/4 (57)	3 1/4 (83)	
*3 1/4 (83)	3 (76)	4 (100)	
*8 1/4 (210)	8 (205)	9 (230)	
10 (255)	9 3/4 (250)	10 3/4 (275)	
12 (305)	11 3/4 (300)	12 3/4 (325)	
15 (380)	14 3/4 (375)	15 3/4 (400)	
18 (455)	17 3/4 (450)	18 3/4 (475)	

**NOTE:** When nipple lengths between 3 1/4" (83) and 8 1/4" (210) are specified, the 8 1/4" (210) nipple will be supplied. Nipple must be cut to specified length by others.

\*ABS (Regularly Furnished) other lengths PVC.

DRAWING NUMBER  
S0410Y

SIZE  
A

SCALE:  
NONE

DATE:  
9-15-76

APPROVED BY:

CHECKED BY:  
RS

DRAWN BY:  
JMA

**0410Y,0417Y**

FIGURE NUMBER

WE CAN ASSUME NO RESPONSIBILITY FOR USE OF SUPERSEDED OR VOID DATA

REV.	DATE	DESCRIPTION	BY	CKD. BY
J	7-1-98	Submittal Update	ASL	BS
H	1-26-98	Chg'd Callout	EMB	BS
G	3-7-96	Chg'd Dim	EMB	BS
F	6-7-95	Added Millimeters	EMB	BS

WEIGHT POUNDS	VOLUME CUBIC FEET	FIGURE NUMBER
		<b>0410Y,0417Y</b>

**DRAWING NUMBER S0100BS**

**SIZE A**

**SCALE: NONE**

**DATE: 1-16-85**

**APPROVED BY: JD**

**CHECKED BY: CR**

**DRAWN BY: VGD**

**100/400 Series Back Sheet**

**MODIFICATIONS & VARIATIONS FOR SIPHON JET WATER CLOSETS**

**RECOMMENDED SETTING OF CLOSET OUTLET CONNECTION AND FIXTURE STUDS**

Manufacturers have slight differences in the depth of the closet horn and flange thickness of their closets. Usually the fixture support closet connection should extend 5/16" (8) beyond face of finished wall (Dimension "R") and the fixture studs 2 1/4" (57) (Dimension "X"). For exact dimensions please use the formulas below.

**DETAIL A** Formula for "R" is:  $S + 1/16" (2) - D = R$ .  
 S = Depth of closet horn  
 1/16" (2) = Distance closet is to set away from finished wall.  
 D = 1/2" (13) for felt gasket and 3/8" (10) for neoprene gasket.  
 R = Distance coupling should extend beyond finished wall.  
 NOTE: When the fixture is installed, closet gasket must be compressed sufficiently to assure a gas and water-tight seal.

**DETAIL B** Formula for "X" is:  $Y + 1/16" (2) + 9/16" (14) = X$ .  
 Y = Thickness of closet wall flange.  
 1/16" (2) = Distance closet is to set away from finished wall.  
 X = Distance supporting stud should extend beyond finished wall.  
 NOTE: Bearing nuts and washers must be set to take full loading from the fixture allowing 1/16" (2) clearance between fixture and wall.

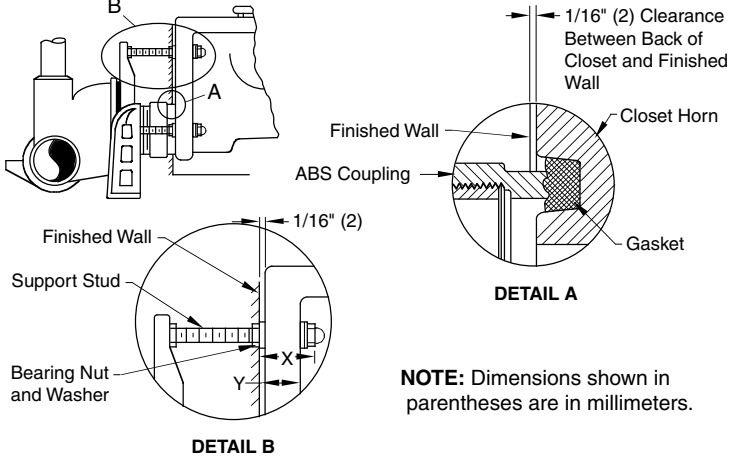

**OPTIONAL CLOSET OUTLET CONNECTIONS**

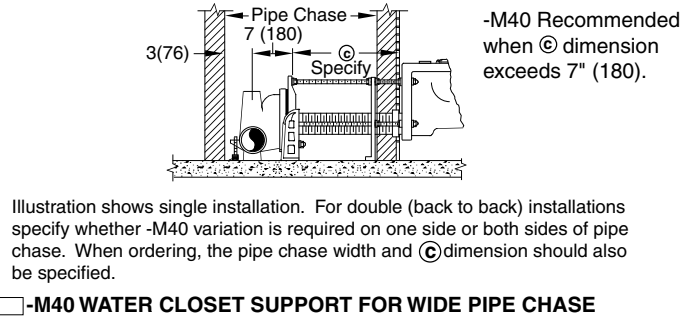
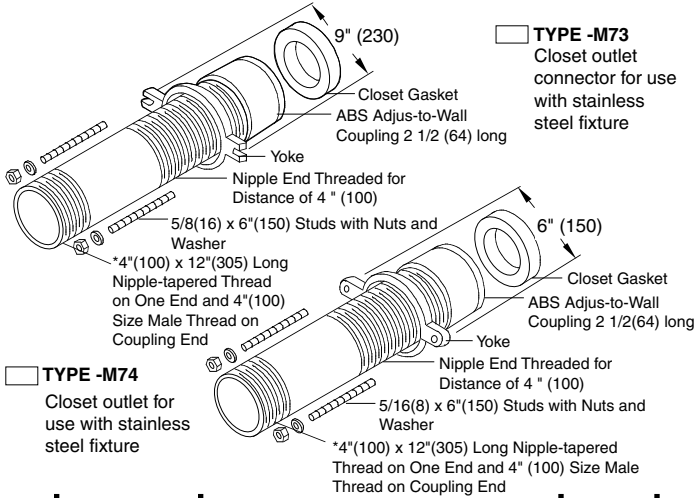
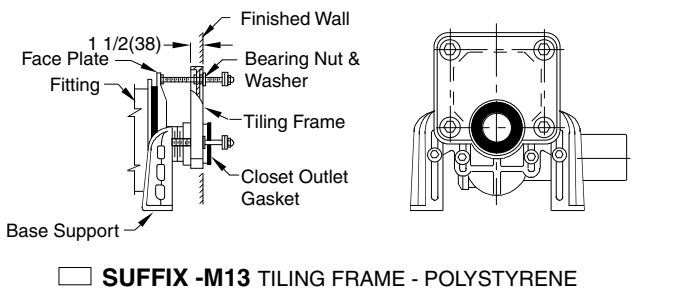
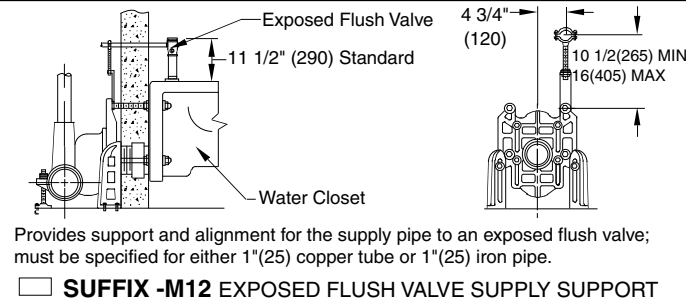
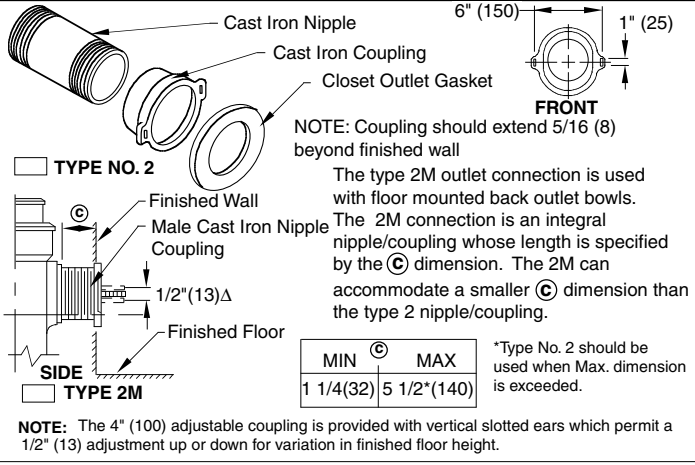

<b>FIGURE NUMBER</b>	<b>C B A</b>	<b>12-10-03</b> <b>2-26-96</b> <b>7-1-93</b>	<b>Added Note</b> <b>Added Millimeters</b> <b>Submittal Update</b>	<b>RN</b> <b>EMB</b>	<b>CL</b> <b>BS</b> <b>BS</b>	<b>WEIGHT</b> <b>POUNDS</b>	<b>VOLUME</b> <b>CUBIC FEET</b>	<b>FIGURE NUMBER</b> <b>100/400 Series</b> <b>Back Sheet</b>
REV.	DATE	DESCRIPTION	BY	CKD. BY				

WE CAN ASSUME NO RESPONSIBILITY FOR USE OF SUPERSEDED OR VOID DATA

DIMENSIONS ARE SUBJECT TO MANUFACTURERS TOLERANCE AND CHANGE WITHOUT NOTICE