

BACKWATER VALVES

SEWER VALVES

FUNCTION: Used in main or branch sewer lines to protect basements and low areas against backflow from the street sewers. Valve design permits access to backwater valve assembly, for servicing or cleaning, through a "full opening" bolted cover or threaded cover.

BOLTED COVER

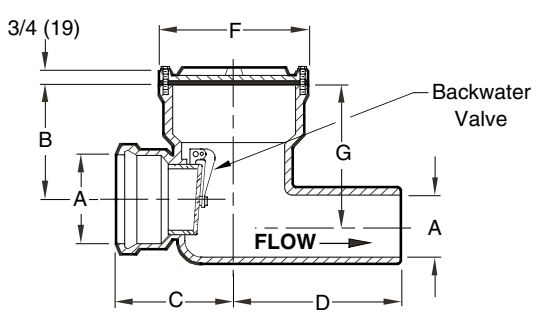

Fig. 7012S . . . HUB INLET - SPIGOT OUTLET

THREADED COVER

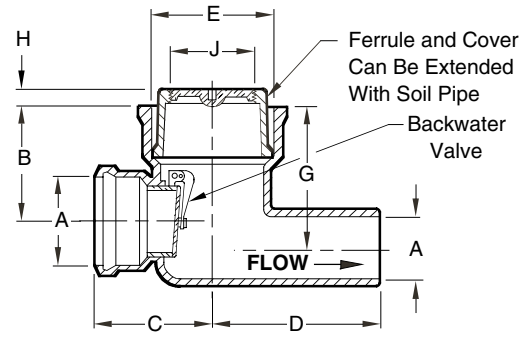

Fig. 7022S . . . HUB INLET - SPIGOT OUTLET

A* SIZE	B	C	D	E SIZE	F DIA	G	H	J SIZE
02 (50)	4 1/2 (115)	5 (125)	7 (180)	4 (100)	6 1/2 (165)	6 (150)	1 1/4 (32)	3 1/2 (89)
03 (80)	6 1/4 (160)	5 3/4 (145)	9 (230)	5 (125)	7 1/2 (190)	7 1/2 (190)	1 1/2 (38)	4 (100)
04 (100)	6 1/2 (165)	6 1/2 (165)	9 1/2 (240)	6 (150)	8 1/2 (215)	8 (205)	1 (25)	5 (125)
05 (125)	7 (180)	7 3/4 (195)	10 1/2 (265)	8 (180)	10 3/4 (275)	8 3/4 (220)	1 (25)	6 (150)
06 (150)	8 (205)	7 3/4 (195)	11 1/2 (290)	8 (180)	10 3/4 (275)	9 3/4 (250)	1 (25)	6 (150)
08 (200)	9 1/2 (240)	9 1/2 (240)	12 1/2 (320)	10 (255)	13 (330)	11 3/4 (300)	1 (25)	6 (150)

* Sized for Service Weight and/or NO-HUB

NOTE: B.W.V. flapper set at factory to hang in closed position. Pin can be moved to permit flapper to hang open 1/4" (6) to permit air circulation.

NOTE: Dimensions shown in parentheses are in millimeters.

NOTE: These valves offer protection against backwater surges. Backflow is prevented when valve is not obstructed by debris or sludge. Use for gravity flow only, not for pressurized applications.

REGULARLY FURNISHED:
 Duco Cast Iron Body with Bronze Backwater Valve. Cover as Indicated by Figure Number Selected.

OPTIONAL MATERIALS:
 Galvanized Cast Iron -G
 Stainless Steel (Fig. 7012 only)
 (Specify Fig. 9795)

FIGURE NUMBER **7012/7022**
 DRAWN BY: **BS**
 CHECKED BY: **DT**
 APPROVED BY: **SJM**
 DATE: **4-28-83**
 SCALE: **NONE**
 SIZE: **A**
 DRAWING NUMBER **S7012**

WE CAN ASSUME NO RESPONSIBILITY FOR USE OF SUPERSEDED OR VOID DATA
 DIMENSIONS ARE SUBJECT TO MANUFACTURERS TOLERANCE AND CHANGE WITHOUT NOTICE

F E D C	7-10-95 8-17-94 4-20-93 2-16-93	Added Millimeters Submittal Update Chg'd Table Redrawn & Chg'd Reg. Furn	EMB EMB EMB	BS BS BS JCS	WEIGHT POUNDS	VOLUME CUBIC FEET	FIGURE NUMBER 7012/7022
REV.	DATE	DESCRIPTION	BY	CKD. BY			