



STYLIST GROUP

SCHEDULE
S-2 SINK

SL-ADA - SERIES - A - 18 GA.

**GENEROUS CAPACITY - LEDGE TYPE
SINGLE COMPARTMENT**

SUBMITTAL DATA



ADA COMPLIANT

SPECIFICATION

Seamless die-drawn construction of type 304, 18-8 stainless steel. Interior and top surfaces polished to a non-porous Hand-Blended Just Finish with highlighted bowl rim. Fully coated underside insulates for sound, and reduces condensation. Straight-sided compartment with 1 3/4" radius corners provides greater capacity. Self-rimming top mount Grip-Rim Plus with 300 series stainless steel mounting channels. Conforms to ASME/ANSI A112.19.3M. Drain punch #35 centered for Just J-35 unless otherwise specified.

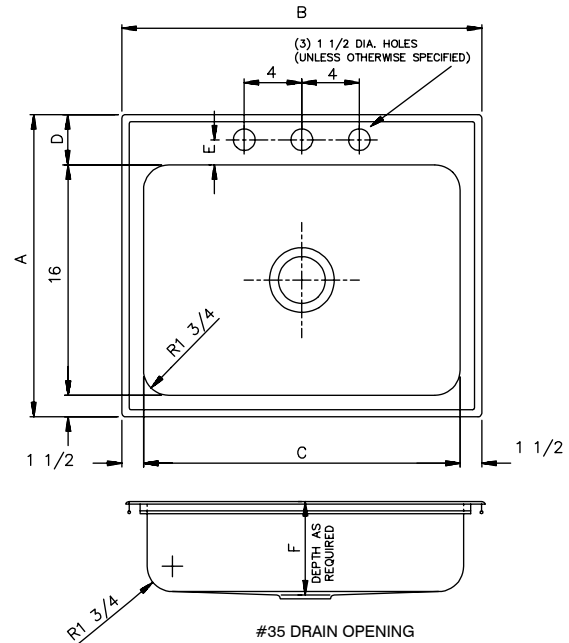
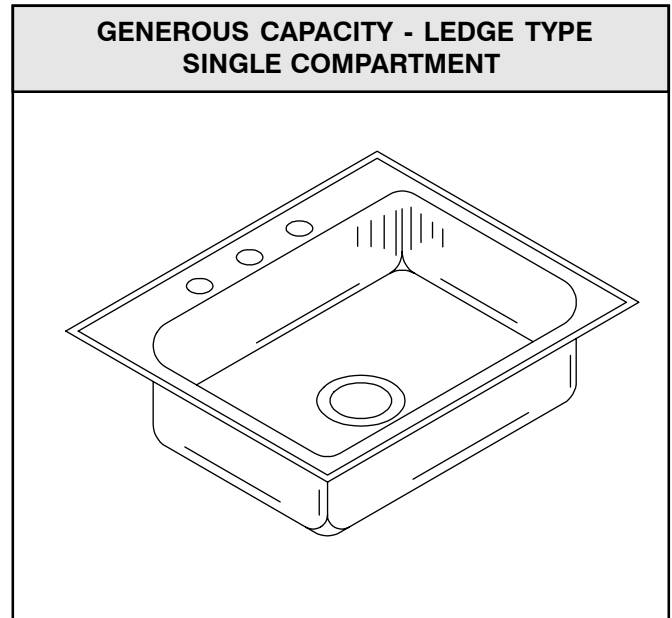

To be specified :

■ Faucet hole punching:

- (1) Hole Centered (2) Holes on 4" centers
- (3) Holes on 4" centers(illustrated) (4) Holes
- Alternate Punching:
Faucet Model: _____
Punching required: _____

DRAIN LOCATION MUST BE SPECIFIED(Circle one):

- CENTER (SHOWN)
- LEFT REAR
- RIGHT REAR
- CENTER REAR

**LOCATIONS MUST BE A MINIMUM OF
4 1/2" FROM THE BOWL WALL.**

JUST MFG. COMPANY CONTINUES TO MAKE QUALITY AND FUNCTIONALITY A MARK OF THE JUST PRODUCT LINE. TO DO SO REQUIRES THAT WE RESERVE THE RIGHT TO CHANGE PRODUCT INFORMATION WITHOUT NOTICE. FOR THE MOST CURRENT AND ACCURATE INFORMATION REGARDING THE COMPLETE LINE OF JUST SINKS, FAUCETS AND DRAINS, CLICK ON THE **SPEC LINE DRAWINGS** LINK ON OUR WEB SITE AT www.justmfg.com

Job Name _____	
Customer _____	
Architect/Engineer _____	
APPROVED FOR MANUFACTURING	
MODEL NO. _____	QTY. _____
COMPANY _____	
TITLE _____	DATE _____
SIGNATURE _____	

MODEL NO.	A	B	C	D	E	F	CUTOUT*
SL-ADA-2125-A-GR	21	25	22	3-1/2	1-3/4	4-1/2 to 6-1/2	20-1/4 x 24-1/4
SL-ADA-2131-A-GR	21	31	28	3-1/2	1-3/4	4-1/2 to 6-1/2	20-1/4 x 30-1/4
SL-ADA-2133-A-GR **	21	33	28	3-1/2	1-3/4	4-1/2 to 6-1/2	20-1/4 x 32-1/4
SL-ADA-2219-A-GR	22	19	16	4-1/2	2	4-1/2 to 6-1/2	21-1/4 x 18-1/4
SL-ADA-2222-A-GR	22	22	19	4-1/2	2	4-1/2 to 6-1/2	21-1/4 x 21-1/4
SL-ADA-2225-A-GR	22	25	22	4-1/2	2	4-1/2 to 6-1/2	21-1/4 x 24-1/4
SL-ADA-2231-A-GR	22	31	28	4-1/2	2	4-1/2 to 6-1/2	21-1/4 x 30-1/4
SL-ADA-2233-A-GR **	22	33	28	4-1/2	2	4-1/2 to 6-1/2	21-1/4 x 32-1/4

* Cutout dimensions shown (Front-to-Back) x (Left-to-Right) -
Corners of cutout may be square or up to 1/2" radius.
** 2-1/2" side flanges

JUST MANUFACTURING COMPANY

9233 KING STREET . FRANKLIN PARK . ILLINOIS . 60131-2111

PH: 847-678-5150 . FAX: 847-678-6817

E-MAIL: custserv@justmfg.com . www.justmfg.com