

ENG. NO. 85801-H
 PAT. NO. 5,379,936.
 PAT. NO. 5,011,074.

Thermostatic Mixing Valve Model 911®E Emergency Shower Eyewash Unit No. 85801

 ASSE 1071 Approved

Inlets & Outlet
 are 1 1/4" NPT

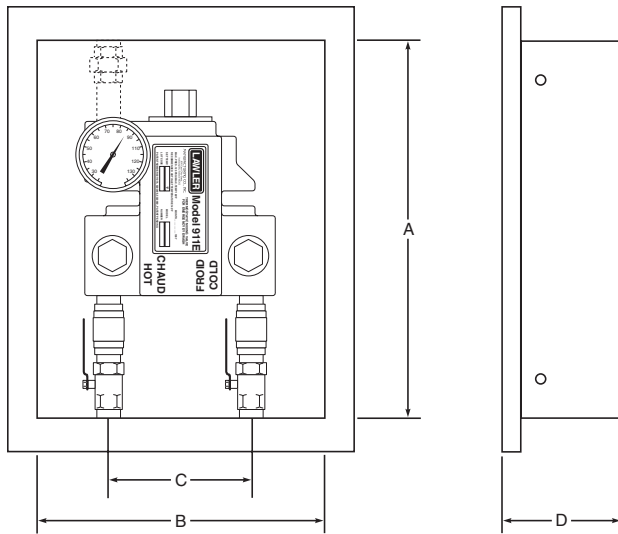

The Emergency Shower and Eyewash Mixing Valve shall control outlet temperature over a wide range of flow and shall be suitable for a single shower or for single or multiple eyewash applications in order to comply with ANSI standard Z358.1-2004. The valve shall include a thermometer to measure the temperature of the stream. Temperature adjustment shall be vandal-resistant.

The control mechanism shall employ a liquid-filled thermostatic motor to drive the valve without additional power requirements. The control mechanism shall employ a stainless steel sliding piston control device with reverse seat closure and both fixed and variable cold water bypass.

In the event of interruption of the cold water supply, the control mechanism closes off the hot water port, stopping all flow. Positive hot water shut-off.

In the event of interruption of the hot water supply, the control mechanism shall allow cold flow through both the fixed and variable bypass.

In the event that the liquid motor fails, the control mechanism closes off the hot water port with the reverse seat and fully opens the internal variable bypass to allow cold water flow.

Unit is completely assembled and tested. See below for cabinet specifications. Cabinet is supplied separately.

- Maximum Inlet Pressure:** 125 PSI.
- Recommended Operating Pressure:** 65 PSI.
- Minimum Supply Pressure:** 35 PSI.
- Recommended Inlet Temperature:** 120°F.*

VALVE FINISH
 Rough Bronze Chrome Plate

TEMP. RANGE **SET POINT**
 70° to 90°F 85°F

*When supplying 140°F or greater, additional outlet controls should be used.

LAWLER
MANUFACTURING CO., INC.
 5330 East 25th Street
 Indianapolis, Indiana 46218
 Phone (317) 261-1212
 Fax (317) 261-1208

Helps meet
 ANSI standard
 Z358.1-2004

DIMENSIONS:

Cabinet Style	A	B	C	D
Recessed	23"	19"	5"	6 3/4"
Surface Mounted	23"	19"	5"	6 3/4"

General Purpose – Cabinet Specifications:

	STAINLESS	CARBON STEEL
Body:	18 Ga.	16 Ga.
Door:	18 Ga.	16 Ga.
Finish:	Type 304 with No. 4 Finish	Baked enamel painted

VALVE FINISH

Rough Bronze Chrome Plate

TYPE OF CABINET

Recessed **MATERIAL**
 Semi-Recessed Stainless
 Surface Carbon Steel

Cabinet includes lock with two keys.
 Hinged left side, piano type.

CAPACITIES – MODEL 911E

Pressure Drop PSI	5	10	20	30	45
Tempered Flow GPM	9	13	17	25	27
Tempered Flow LPM	34	49	64	94	102

BYPASS CAPACITIES - MODEL 911E

Pressure Drop PSI	5	10	20	30	45
Cold Bypass GPM	7	10	14	21	22
Cold Bypass LPM	26	37	53	79	83

Mounting Bracket

Note: The mixing valve must be installed with inlet check valves and the shower or the Eyewash/Facewash fixture should be installed 4 to 10 feet from the mixing valve. Hot and cold water inlet pressures must be equal.

Provisions shall be made to thermally isolate the valve.

Design and specification subject to change without notice.