



ANCHOR BOLTS

POUR IN PLACE

Anchor Bolt Holder

Fits 1/2" to 3/4" diameter anchor bolts. Anchor bolt locks into e-z bolt sleeve with locking ring and is then placed into the base. Unique design allows for vertical height adjustment of anchor bolts. Assures proper placement of anchor bolts on elevated slabs. Base Plate holder attaches to the decking by nail or staple.

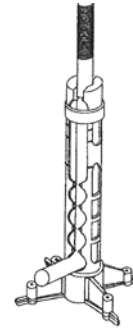

No.	Qty/Ctn	Wt/Ctn (lbs)
AZ ABH	100	16.0

Anchor Bolts

Anchor bolts are fabricated from low carbon steel for use in the limited load requirements of a foundation bolt. Available in 1/2", 5/8" and 3/4" diameters with national course thread. All sizes are furnished with N.C. nut only.

No.	Size	Wt (lbs)	Qty/Bag
CT 126BOLT	1/2" x 6"	0.35	100 pcs
CT 128BOLT	1/2" x 8"	0.45	100 pcs
CT 1210BOLT	1/2" x 10"	0.51	100 pcs
CT 1212BOLT	1/2" x 12"	0.61	100 pcs
CT 588BOLT	5/8" x 8"	0.70	50 pcs
CT 5810BOLT	5/8" x 10"	0.82	50 pcs
CT 5812BOLT	5/8" x 12"	1.0	50 pcs
CT 348BOLT	3/4" x 8"	1.1	50 pcs
CT 3410BOLT	3/4" x 10"	1.3	50 pcs
CT 3412BOLT	3/4" x 12"	1.5	50 pcs
Hot Dipped Galvanized			
CT 1210BOLTHD	1/2" x 10"	0.51	100
CT 5810BOLTHD	5/8" x 10"	0.82	50
CT 5812BOLTHD	5/8" x 12"	1.0	50
CT 3410BOLTHD	3/4" x 10"	1.3	50
CT 3412BOLTHD	3/4" x 12"	1.5	50

Other sizes available on request.



Washers

Washers are used with all sizes of bolts and rod. The washers are fabricated from carbon steel.

No.	Size	Wt (lbs)
CT 12WASH	1/2"	0.04
CT 58WASH	5/8"	0.08
CT 34WASH	3/4"	0.11
CT 1WASH	1"	0.17
CT 114WASH	1-1/4"	0.21



Nuts - N/C

Nuts are used with all sizes N/C bolts and rod, the nut are fabricated from carbon steel.

No.	Size	Wt (lbs)
CT 12NUT	1/2"	0.04
CT 58NUT	5/8"	0.08
CT 34NUT	3/4"	0.12
CT 1NUT	1"	0.32



Anchor Bolt Sleeve

The unique high-density polyethylene plastic design provides flexibility. If sizing is required, simply cut the sleeve at the gage line as shown. Anchor Bolt Sleeves provide a grout pocket around the anchor bolt to allow the bolt to be positioned exactly. They provide a quick, easy way to make final adjustments and a clean pocket for grouting at lower cost than other methods.

No.	Bolt Size	Sleeve Size	Wt (lbs)	Qty/Ctn
SI 1701	1/2", 3/4"	2" x 5"	0.10	100
SI 1704	5/8", 3/4", 7/8"	2" x 7"	0.10	100
SI 1706	1", 1-1/4"	3" x 10"	0.26	50
SI 1708	1-1/2", 1-3/4"	4" x 15"	0.60	20
SI 1710	2", 2-1/4"	4" x 18"	0.75	20

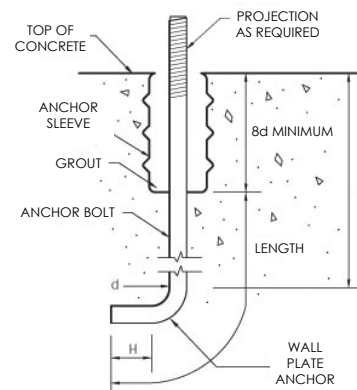

ANCHOR BOLTS



POUR IN PLACE

Stab Bolts

The Stab Anchor Bolt is the first tested and inspected friendly anchor bolt for holdowns. Extensive testing has been done to determine the design load capacity at a common application, the garage stem wall. Special features include; Rolled threads for higher tensile capacity; Offset angle reduces side bursting and provides more concrete cover; Stamped bolt head for identification after pour; Stamped embedded line to aid installation; and, Configuration results in minimum rebar interference. Suitable for monolithic and two pour installations. Nuts and washers are not supplied.

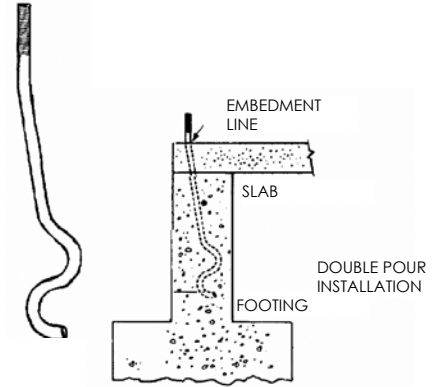

No.	Description	Simp EQ	USP EQ	KC EQ	Wt (lbs)	Qty/Ctn
CT KCAB16	5/8" x 17"	SSTB16	STB16	KCAB16	1.33	50
CT KCAB24	5/8" x 24"	SSTB24	STB24	KCAB24	1.95	50
CT KCAB28	7/8" x 29"	SSTB28	STB28	KCAB28	4.55	50

Stab Bolt Holder

Designed to hold the anchor in place before the concrete pour, as required in some jurisdictions. Built-in 2x4 and 2x6 stops eliminate measuring. Elevated bolt grippers allow easy trowel finishing. Color-coded for easy size identification. Lightweight, durable and easy to use. Reusable yet cost-efficient for single application. Threaded grippers hold each bolt in the exact same location and height. They secure bolt in place without nut for quicker set-up and tear-down, and protect threads from splashing concrete. Use the 5/8" and 7/8" Anchor Bolt Holders to secure the SSTB to the formboard before the concrete pour. Available in 100 per carton.

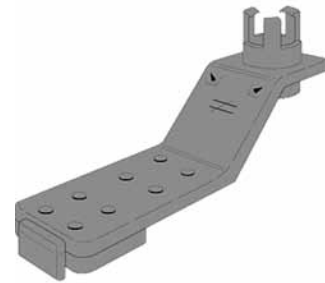

No.	Dia	Color	Wt (lbs)
CT AM58	5/8	Blue	7.15
CT AM78	7/8	Green	7.15

Plate Washers

Used with anchor bolts to provide adequate bearing against wood members.

No.	Size	Rod Diameter	Wt (lbs)	Qty/Ctn
PW 122	2" x 2" x 3/16"	1/2"	0.20	100
PW 342	2" x 2" x 3/16"	3/4"	0.60	80
PW 582	2" x 2" x 3/16"	5/8"	0.20	100
Hot Dipped Galvanized Finish				
PW 582HD	2" x 2" x 3/16"	5/8"	0.75	50
PW 123HD	3" x 3" x 1/4"	1/2"	0.60	50
PW 343HD	3" x 3" x 1/4"	3/4"	0.50	50
PW 583HD	3" x 3" x 1/4"	5/8"	0.60	50

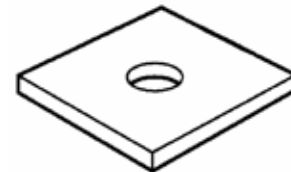



HOLD DOWNS

M A S C O . N E T

POUR IN PLACE

Strap Anchors

Strap Anchors are made of 12 gauge galvanized steel. Meets specifications for a variety of wood-to-concrete or applications including seismic anchorage for concrete walls-to-floor details. For anchor down use, the SSAD series has a 1 piece design, no separate anchors are required. Supplied with zinc plated finish.



No.	Description	Simp EQ	KC EQ	USP EQ	Wt (lbs)	Qty/Ctn
CT SSAD10	10" x 12 ga.	STHD10	SSAD10	STAD10	3.16	10
CT SSAD10RJ	10" x 12 ga. Rim Joist	STHD10RJ	SSAD10RJ	STAD10RJ	4.30	10
CT SSAD14	13" x 12 ga.	STHD14	SSAD14	STAD14	4.40	10
CT SSAD14RJ	13" x 12 ga. Rim Joist	STHD14RJ	SSAD14RJ	STAD14RJ	5.00	10

Hold Downs

Designed to be installed at the edge of concrete forms. Tests determined the pullout strength with one horizontal #4 rebar in the shear cone. Install before pouring concrete by nailing to the form. Installation holes allow nailing to the form, resulting in deeper embedment. Supplied with zinc plated finish.

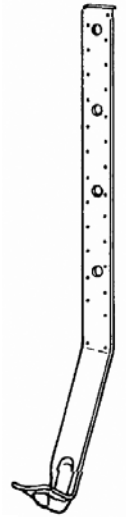
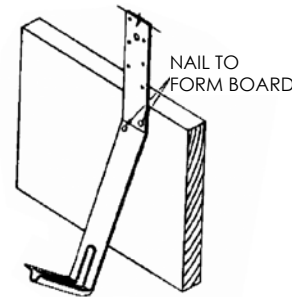

No.	Description	Simp EQ	KC EQ	USP EQ	Wt (lbs)
CT KHPAHD22	35" x 10 ga.	HPAHD22	HSA3522	HPAHD22	2.5

Column Bases

Accommodate heavy column bases and rough sawn posts or heavy duty fence construction where high structural values and durable performance are part of the specifications. Anchors should set in position before pouring concrete. Erection nail holes are provided to speed up installation. Supplied with painted black finish.

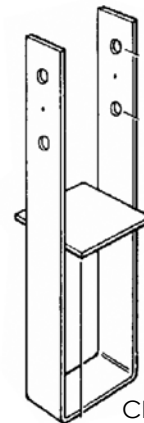

CB

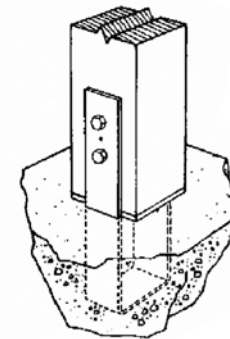

TYPICAL CB INSTALLATION

No.	Description	Simp EQ	KC EQ	ESP EQ	Wt (lbs)
CT 44CB	4" x 4"	CB44	HA44	KCB44	4.5
CT 46CB	4" x 6"	CB46	HA46	KCB46	6.6
CT 66CB	6" x 6"	CB66	HA66	KCB66	8.1

Post Holders

For use with a variety of dimensional lumber and composite wood sizes. Low cost post base for patios, carports, breezeways and porches. Use all specified fasteners. Optional holes may be used to temporarily secure members while drilling and bolting. Supplied with painted black finish.

No.	Description	Simp EQ	KC EQ	USP EQ	Wt (lbs)
CT 448PH	4" x 4" x 8"	EPB44	EA44	EPB4408	1.6
CT 4412PH	4" x 4" x 12"	EPB44-12	EA44-12	EPB4412	2.1
CT 4612PH	4" x 6" x 12"	EPB46-12	EA46-12	EPB4612	2.7
CT 6612PH	6" x 6" x 12"	EPB66	EA66	EPB6612	3.1

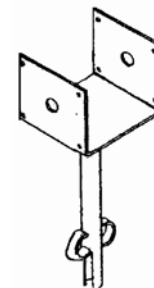

POUR IN PLACE



POUR IN PLACE

Pipe Bollards

Available in 2-3/8" O.D. and 2" I.D. Constructed from Schedule 40 Pipe sized tubing. Surface mount and poured in place types available.

No.	Description	Wt (lbs)
CT PIPE	No Threads	12.0
CT PIPE T	Threaded	10.5
CT PIPE B	Base Threaded	2.5
CT PIPE C	Cap Threaded	1.0
Accessories		
RH WS1432	Wedge anchor	.05
	1/4" x 3-1/4"	

CT PIPE
2" ID



CT PIPE T
2" ID

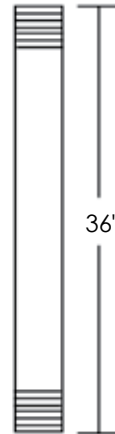

Cap

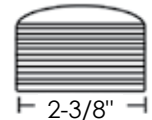

CT PIPE C

Base

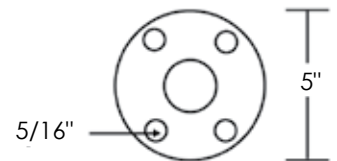

CT PIPE B

SpeedStep Bracket

A reusable, high grade composite resin forming bracket designed to simplify layout, set-up and stripping of concrete stair forming. The brackets are nailed to 2 x 4 stringers and adjusted for a 4" to 8" riser and 10" to 20" tread. One size fits all standard stairs.

No.	Wt (lbs)	Qty/Ctn
CT SS	0.8	10

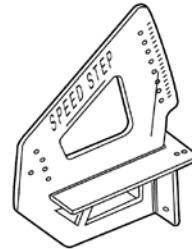

Plastic Area Wells

No.	Size	Color	Pcs/Ctn	Wt/Ctn (lbs)
CT PVW4	19" x 4" x 12"	Grey	10	24.0

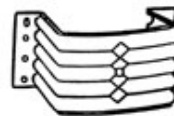

Concrete Area Wells

No.	Size	Color	Wt (lbs)
B AWL	20" x 6" x 8"	Grey	30.0

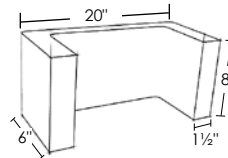

Concrete Curb Bumpers

Concrete curbs available with 2 each 3/4" stake pockets.

No.	Size	Color	Wt (lbs)
B CB	6'	Gray	206.0

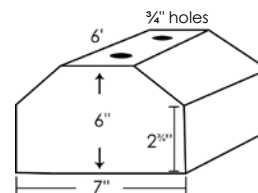



POUR IN PLACE

POUR IN PLACE

Crete Sleeves

To form a smooth perfect hole in concrete cheaper and faster than ever before. Made from practically indestructible linear polyethylene and can be used over again many times. Crete sleeves are adjustable for any slab thickness by telescoping 2 or more together. For thickness less than 8-3/4" or for smooth slab finish, cut off the tops of crete sleeves and push them up through the bottom half.

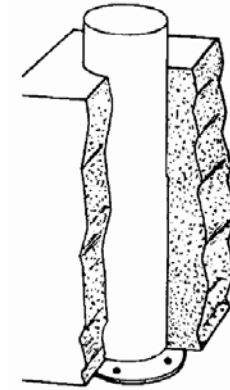

No.	Size	Wt (lbs)	Qty/Ctn (lbs)
CT 112CS	1-1/2" x 8 3/4"	0.12	100
CT 2CS	2" x 8 3/4"	0.22	100
CT 3CS	3" x 8 3/4"	0.30	50
CT 4CS	4" x 8 3/4"	0.38	50
CT 5CS	5" x 8 3/4"	0.50	30
CT 6CS	6" x 8 3/4"	0.63	30
CT 8CS	8" x 8 3/4"	1.10	10
CT 10CS	10" x 9 1/8"	1.90	10
CT 12CS	12" x 9-1/8"	2.0	10

Foundation Vents

The deluxe plastic foundation vent is available in two sizes, also available with attached closures.

No.	Size	Free Area In ²	Wt (lbs)	Qty/Ctn
Grey Color				
CT 6VENT	6" x 7" x 16"	72.5	1.00	20
CT 8VENT	8" x 7" x 16"	72.5	2.00	15
CT 6VENT-W/Closure	6" x 7" x 16"	72.5	1.75	20
CT 8VENT-W/Closure	8" x 7" x 16"	72.5	2.25	15
CT 68COMBO	6", 8" x 7" x 16"	100	2.70	12
CT 68COMBO-W	6", 8" x 7" x 16"	100	2.92	12
Plugs				
CT VP	6 1/2" x 7 3/4"		0.175	40

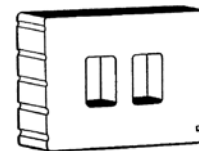

Pier Molds

Cardboard disposable pier mold. 20 per bundle.

No.	Size	Wt (lbs)
CT 18DP	18" x 18" x 8"	0.73
CT 24DP	24" x 24" x 8"	0.90

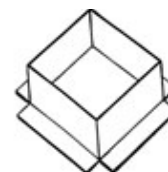

POUR IN PLACE



POUR IN PLACE

Beam Pocket

Plastic Block Outs used for post and beam construction.

No.	Beam Size	Block Out Box Size	Qty/Case	Wt/Ctn (lbs)
CT 46B	4" x 6"	4" x 6"	110	20
CT 48B	4" x 8"	4" x 8"	96	22

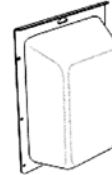

Joist Pocket Liner™

The Joist Pocket Liner™ (JPL) is a polyethylene product manufactured by an injection molding process. The JPL is used for forming a pocket (blockout) in a concrete foundation wall, to support the end of an engineered wood I-joist or a conventional wood joist. The pocket liner creates a moisture barrier and provides a vertical support system for joists in a concrete foundation wall. See product datasheet for installation details.

No.	Description	Qty/Ctn	Wt/Ctn (lbs)
JPL 2-9	2" for 9-1/2" joist	30	10
JPL 25-11	2-1/2" for 11-7/8" joist	30	15

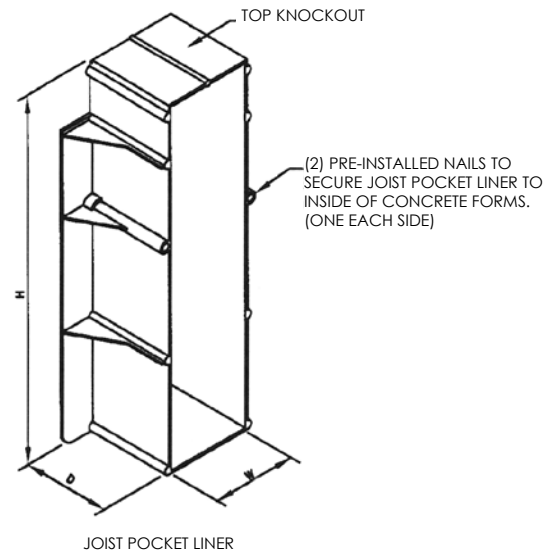



REGLET

POUR IN PLACE

TYPE CO - Concrete

Description: Reglet and Counter flashing system (2-piece, spring-action type). Available in copper, stainless steel, aluminum and galvanized steel.

Application: CAST-IN-PLACE CONCRETE. Not recommended for tilt-up construction (requires special provision to insure proper alignment between concrete panels).

Special Features: Factory-provided removable foam insert protects slot from obstruction during concrete pours.

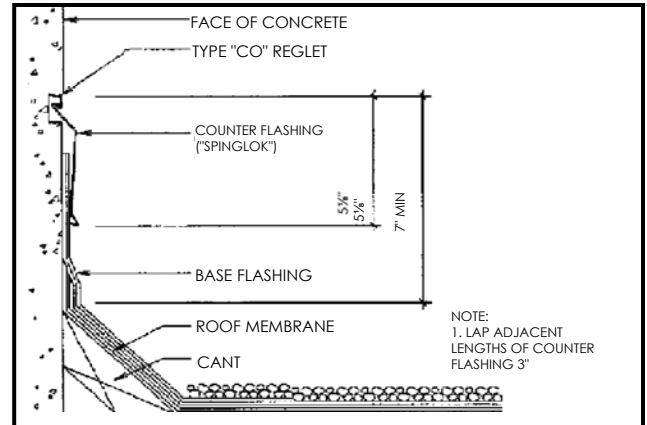

No.	Size	Wt/Pc (lbs)	Lf/Ctn
FRY CO-G	26 ga. galv. x 10'	2.0	250
FRY FLASH-G	26 ga. galv. x 10'	1.7	250

TYPE MA - Masonry

Description: Reglet and counter flashing system (2-piece spring-action type). Reglet with 1-1/2" flange and counter flashing are available in copper, stainless steel, aluminum and galvanized steel. Reglet with 4" flange is available in copper, stainless steel and steel.

Application: BRICK or CONCRETE MASONRY UNIT (CMU).

Special Features: Reglet is available with 1-1/2" horizontal flange (Reglet Type MA-1.5) for brick and 4" horizontal flange (Reglet Type MA-4) for CMU.

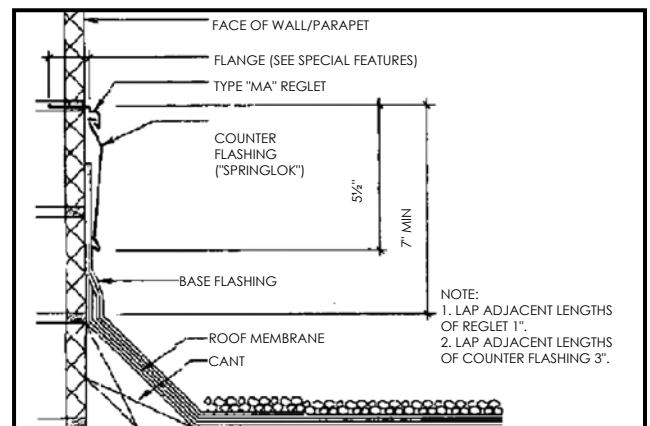

No.	Size	Wt/Pc (lbs)	Lf/Ctn
FRY MA-G	1-1/2" x 24 ga. galv. x 10'	2.7	250
FRY FLASH-G	26 ga. galv. x 10'	1.7	250

(Continued on next page)

REGLET



POUR IN PLACE

TYPE SM - Surface Mount

Description: Reglet and counter flashing system (2-piece, spring-action type). Available in copper, stainless steel, aluminum, and galvanized steel.

Application: SURFACE MOUNT (pre-cast concrete, tilt-up concrete and retrofit applications over concrete, brick, and CMU). Requires sealant (silicon or polyurethane).

Special Features: Reglet supplied with neoprene-faced stainless steel washer for proper fastening.

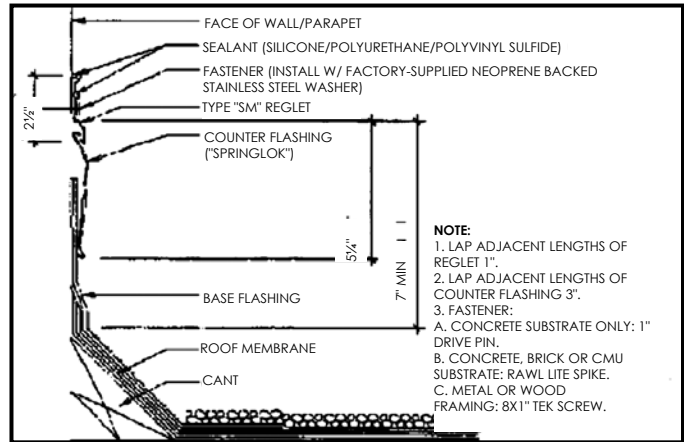

No.	Size	Wt/Pc (lbs)	Lf/Ctn
FRY SM-G	24 ga. galv. x 10'	2.0	250
FRY FLASH-G	26 ga. galv. x 10'	1.7	250

STAIR NOSING

Safety Stair Nosing

Designed for heavy duty use indoors and outdoors, these safety nosings meet and exceed all OSHA and Barrier-Free requirements. Safety Stair Nosings are impact resistant. The nosings are manufactured from an extruded aluminum base filled with a mixture of anti-slip abrasive granules in an advanced formula epoxy binder. Their remarkable strength is capable of absorbing heavy impact. Each abrasive filled rib projects above the aluminum base for the greatest exposure of anti-slip surface. Nosings should terminate not more than 3" from ends of steps for poured concrete stairs; for concrete filled steel pan stairs, nosings should be full length of steps less 1/8" clearance. Lengths up to 12'-0" maximum in one piece.

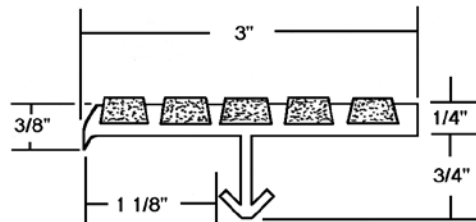

Designed to install so that there is no projection past the face of the riser.

No.	Size	Wt/lf
AS 9511	1/4" x 3" x 12'	1.17

Extruded Anchor

Extruded anchors run full length of tread for positive anchorage and quick installation. Since extruded anchors are concealed, no bolt holes appear on the tread surface.

Renovation Treads

Make slippery stairs safe again. Renovate and update any stairway without the costly labor of removing and rebuilding the old stair. Renovation treads meet ADA requirements and install easily over worn stairways of every type including concrete, wood, steel, marble and terrazzo. They can be used inside and outside and are ideal for heavy traffic stairways. Ready for immediate installation by anyone who can handle a screwdriver. The attractive colors renew old, worn stairways. Drab and unsafe stairs become bright and contemporary with anti-slip protection at every step.



STAIR NOSING

M A S C O . N E T

POUR IN PLACE

Profiles for New Concrete Stairs and Steel Pan

Poured concrete: Install full step length less approximate 3" clearance.

Steel Pan: Concrete filled, installed stringer to stringer less 1/8" clearance.

Sections not to scale

FOR STEEL PAN STAIRS

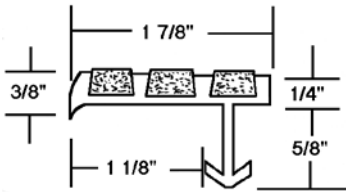

AS 9311
1-7/8" wide, 1/4" thick
1.00 lb/lf

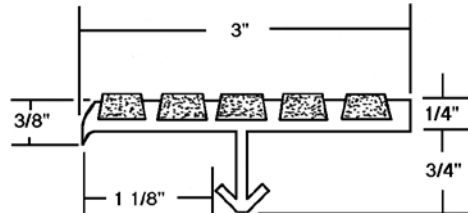

AS 9511
3" wide, 1/4" thick
1.17 lb/lf

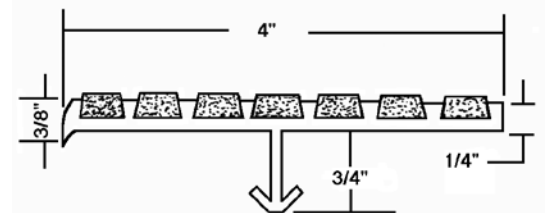

AS 9711
4" wide, 1/4" thick
1.50 lb/lf

FOR POURED CONCRETE STAIRS

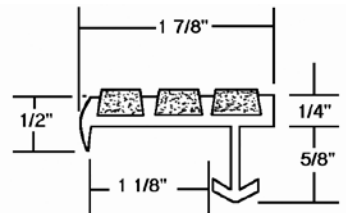

AS 3311
1-7/8" wide, 1/4" thick
1.00 lb/lf

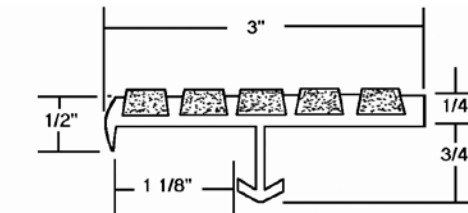

AS 3511
3" wide, 1/4" thick
1.17 lb/lf

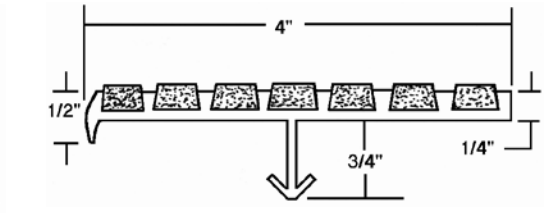

AS 3711
4" wide, 1/4" thick
1.50 lb/lf

FOR CONCRETE STAIRS

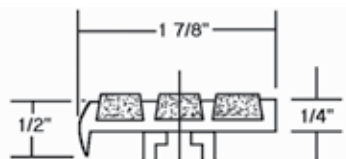

AS 3301
1-7/8" wide,
1/4" thick
1.00 lb/lf

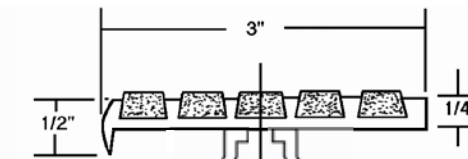

AS 3501
3" wide,
1/4" thick
1.17 lb/lf

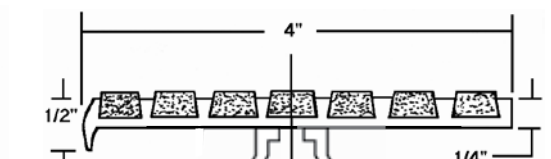

AS 3701
4" wide,
1/4" thick
1.50 lb/lf

RENOVATION TREADS

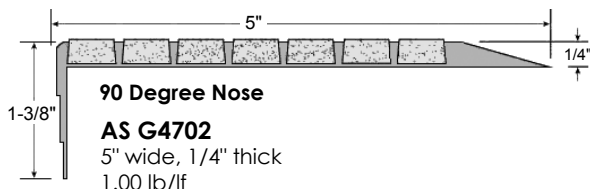

90 Degree Nose
AS G4702
5" wide, 1/4" thick
1.00 lb/lf

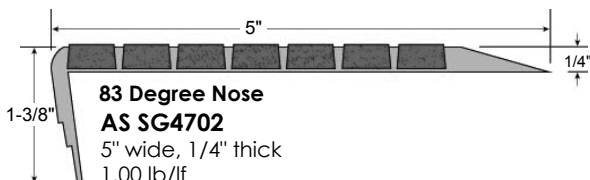

83 Degree Nose
AS SG4702
5" wide, 1/4" thick
1.00 lb/lf

NOTE: Nose design provides better fit at former edge of steel pan.

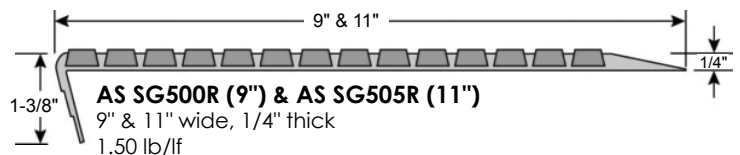
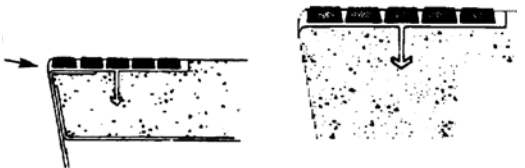

AS SG500R (9") & AS SG505R (11")
9" & 11" wide, 1/4" thick
1.50 lb/lf

TRENCH DRAIN



POUR IN PLACE

Lightweight 4 ft. modular sections
Easier handling and installation
Lower freight costs

.7% built-in slope
Maintains optimum flow rates
throughout system

Polyethylene material
Durable and inexpensive
Less beakage versus concrete
Chemical resistance

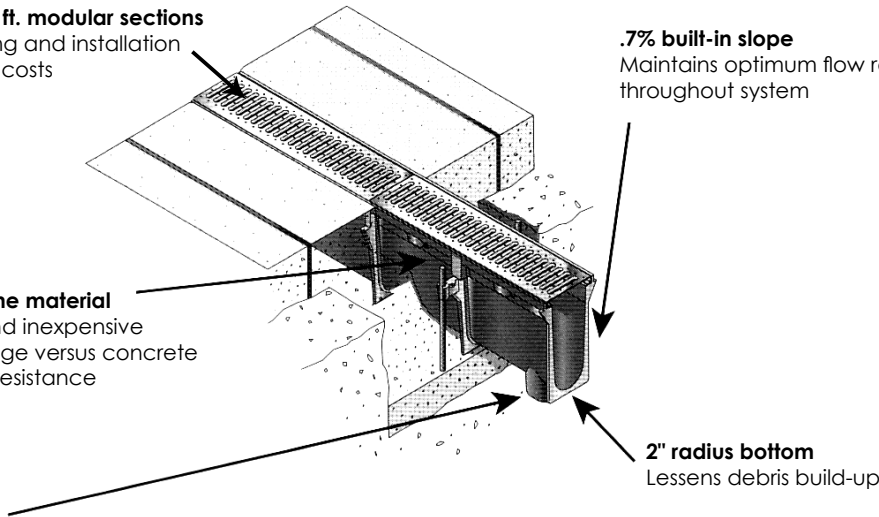

2" radius bottom
Lessens debris build-up

Bottom outlet on each channel section
System versatility
Requires fewer accessories

DURA SLOPE™

An economical alternative to traditional heavy concrete trench drain systems. Dura Slope™ won't break like concrete if dropped, yet it's much lighter. Dura Slope™ channels may be cut to any length with hand tools. Its light weight means it is easier to load, unload, and carry. And it doesn't over-burden vehicles like heavy polymer concrete. Fast and easy to assemble—most jobs can be laid out and poured the same day. Channel sections simply snap together. Integral re-bar supports are designed to grip #3 or #4 re-bar (3/8" – 1/2") for easier channel height adjustment during installation. And exclusive DuraLoc™ tongue-and-groove ends snap-lock into place, making precise fit and straight channel runs easy. Applications include driveways, parking areas, warehouses, loading docks, gas station entrances, and other areas for the interception and collection of surface run-off.

No.	Size	Inlet Dim Start	Outlet Dim End	Wt (lbs)
Channels				
NDS DS090N	48"	3.99	3.99	7.45
NDS DS091	48"	3.99	4.33	7.52
NDS DS091N	48"	4.33	4.33	7.81
NDS DS092	48"	4.33	4.67	7.92
NDS DS093	48"	4.67	5.00	8.26
NDS DS094	48"	5.01	5.34	8.63
NDS DS094N	48"	5.34	5.34	8.92
NDS DS095	48"	5.34	5.67	8.99
NDS DS096	48"	5.67	6.01	9.36
NDS DS097	48"	6.01	6.35	9.74
NDS DS097N	48"	6.35	6.35	10.04
NDS DS098	48"	6.35	6.68	10.11
NDS DS099	48"	6.68	7.02	10.48
NDS DS100	48"	7.02	7.35	10.85
NDS DS100N	48"	7.35	7.35	11.15
NDS DS101	48"	7.35	7.69	11.22
NDS DS102	48"	7.69	8.03	11.59
NDS DS103	48"	8.03	8.36	11.97
NDS DS103N	48"	8.36	8.36	12.27
NDS DS104	48"	8.36	8.70	12.34
NDS DS105	48"	8.70	9.03	12.71
NDS DS106	48"	9.03	9.37	13.08
NDS DS107	48"	9.37	9.71	13.45
NDS DS108	48"	9.71	10.04	13.82
NDS DS109	48"	10.04	10.38	14.20
NDS DS109N	48"	10.38	10.38	14.50
NDS DS110	48"	10.38	10.71	14.57
NDS DS111	48"	10.71	11.05	14.94
NDS DS112	48"	11.05	11.39	15.31
NDS DS113	48"	11.39	11.72	15.68
NDS DS114	48"	11.72	12.06	16.06



TRENCH DRAIN

M A S C O . N E T

POUR IN PLACE

No.	Description	Wt (lbs)
Grates		
NDS DS231	2' Slotted Cast Iron	15.00
NDS DS232	2' Slotted Ductile Iron	16.00
NDS 661LG	2' Slotted Polyolefin - Gray	2.92
NDS DS670	2' PERF Polyolefin - Gray	3.00
NDS DS221	2' Slotted Galv Steel	4.00
NDS DS226	2' PERF Stainless Steel	3.22
Accessories		
NDS DS340	6" x 24" x 27" Catch Basin	12.00
NDS DS122	Additional Grate Locking Bar	0.80
NDS DS224	End Cap Solid	0.63
NDS DS126	Bottom Outlet	0.53
NDS DS227	End Cap w/ 4" S&D Pipe Outlet	0.75
NDS DS200	Ductile Iron 6" x 24" Frame	7.50
NDS DS225	Grate/Frame Screws #1/4-20 x 1.5" FH, S/S (2 per Grate)	
NDS DS629	Grate Screws #1/4-20 x 1.5" FH, S/S (2 per Grate)	
NDS 1243	Universal Outlet 3" & 4" for Catch Basin	0.70
NDS 1206	Universal Outlet 6" for Catch Basin	0.35
NDS 1266	Universal Plug 6" for Catch Basin	0.75
NDS DFW56-44	Flexible Adapter 4" to 4" for End Caps	1.00
NDS DFW56-43	Flexible Adapter 4" to 3" for End Caps	1.00

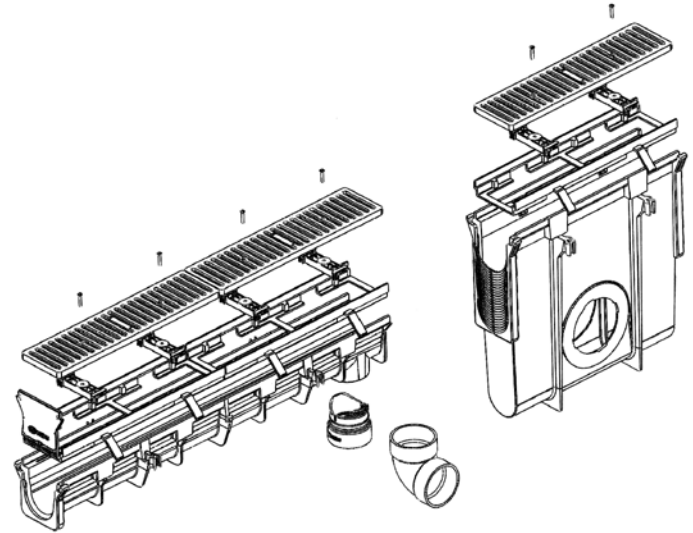

Deck Drain

Deck Drain is a removable top drain that features a double wall base and snap in top (PVC). When installing this drain the tops are staggered past the joints making the joints very rigid. Because the tops are removable, this drain is easy to clean and the tops can be replaced if ever damaged. Deck Drain is used in many residential and commercial swimming pools, patios and other pedestrian traffic areas. Color is grey.

This drain is not designed to be used as a full expansion. It requires that a 3/8" rebar be placed every 36", midway in the drain to prevent damage due to concrete deck movement.

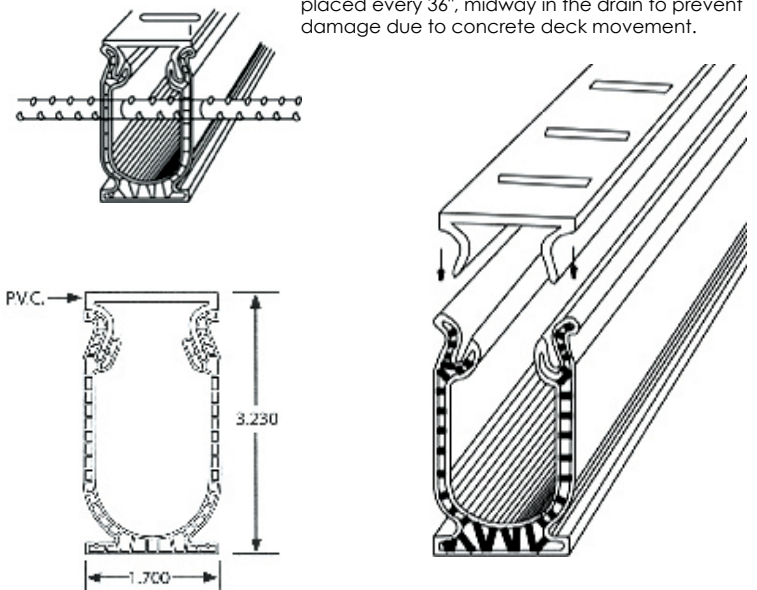

No.	Description	Qty/Ctn	Wt (lbs)
STG SDDG	10' Deck Drain	8	
STG SDDTCG	10' Gray Top Cap	8	
STG SDD90G	90 Degree	10	
STG SDD-TW	Tee	4	
STG DEA	End Adapter	4	
STG DEP	End Plug	10	
STG DCUP	Coupler	12	

TRENCH DRAIN



POUR IN PLACE

Polycast

Precast concrete drains are an improved method of installing drainage systems in concrete slabs. Each channel has built-in 0.65% slope that simplifies installation and guarantees efficient drainage. Precast components eliminate complicated formwork. Just assemble the components inside a prepared excavation and pour the slab. Installation time and labor is a fraction of that required to form a cast-in-place drainage system. Precast channels are made of high strength polymer concrete that resists damage from freeze/thaw and exposure to a wide range of chemicals. The extremely smooth, rounded surface provides maximum liquid flow. All channels come complete with either galvanized steel (light load) or cast iron (medium load) gratings. Standard channel length is 48". A wide selection of grates is

available to handle any situation. For general usage, galvanized steel is standard. The cast iron grate is ideal for medium traffic areas. The fiberglass grate is highly resistant to corrosives. Stainless steel is available for food processing areas. Drainage channels are supplied complete with the specified grate. The system also includes catch basins with removable trash buckets. All channels are numbered and have arrows indicating the flow direction. This versatile system is economical, durable and easy to install. It provides an ideal solution to almost any surface drainage problem. A reinforced frame system is required to resist heavy loads on slabs where hard wheeled traffic is anticipated. Call Mascons for more information on your load requirements and chemical resistance.

No.	Size	Wt (lbs)
Channels		
PC 600-625	4' Polyester Channels	37.0-77.0
Grates		
PC 640	4' Slotted Galv Grate	8.0
PC 641	2' Cast Iron Slotted Grate	15.0
PC 641D	2' Ductile Iron Slotted Grate	13.0
PC 646	4' Perforated Galv Grate	8.0
PC 647	4' Slotted S/S Grate	7.0
PC 644	4' x 5/8" Fiberglass Grate	10.0
PC 657	4' Perforated S/S Grate	8.0
PC 670	2' Duraguard Grate	4.0
PC 640R	4' Slotted Galv Reinforced Grate	12.0
PC 646R	4' Perforated Galv Reinforced Grate	12.0
PC 647R	4' Slotted S/S Reinforced Grate </td <td>12.0</td>	12.0
PC 657R	4' Perforated S/S Reinforced Grate	14.0
Accessories		
PC 700	2' Cast Iron Frame	15.0
PC 700PE	2' Duraguard Frame	2.0
PC 642	Locking Device for Galv Grate	1.0
PC 642B	Locking Design for CI Grates	1.0
PC 642BH	Locking Design for CI Grates/Frames	1.0
PC 642S	Locking Design for S/S Grates	1.0
PC 633	Alignment Chair	1.5
PC 670F	Universal End Cap (Shallow End)	0.5
PC 670M	Universal End Cap (Deep End)	0.5
PC 650	6" x 24" Catch Basin	94.0
PC 651	12" x 24" Catch Basin	125.0
PC 643	12" x 24" Cast Iron Grate	63.0
PC 650TA	650 Trash Bucket Plastic	3.0
PC 651TA	651 Trash Bucket Plastic	4.0

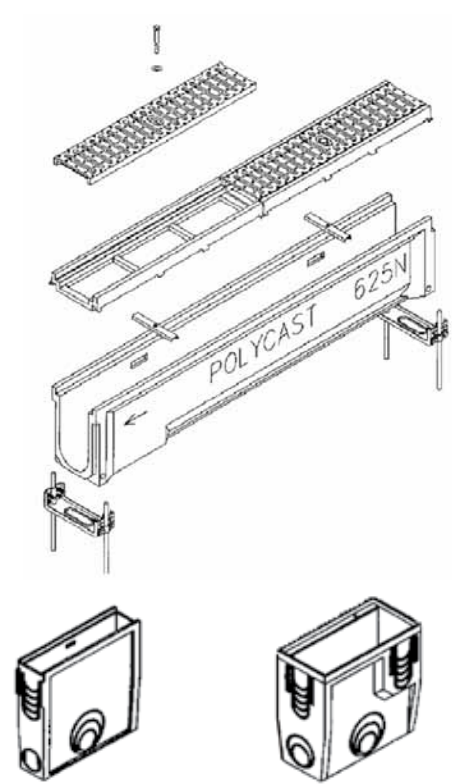
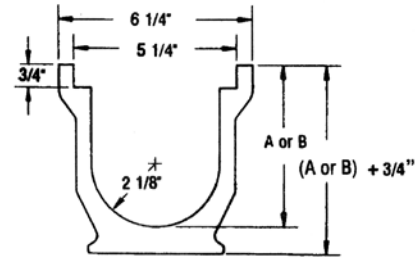

650 catch basin

651 catch basin



TRENCH DRAIN

M A S C O . N E T

POUR IN PLACE

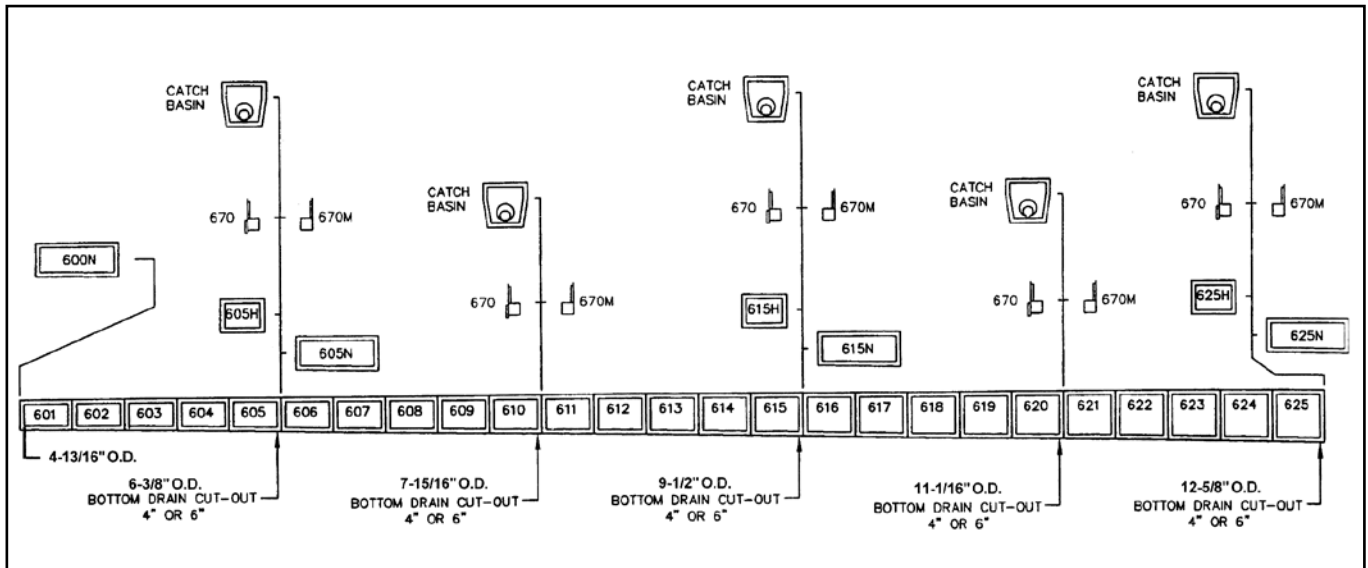

Channel Number	Weight Lbs	Inlet Dim 'A'	Outlet Dim 'B'	Channel Number	Weight lbs	Inlet Dim 'A'	Outlet Dim 'B'
PC 600N	37	4-1/16	4-1/16	PC 614	59	8-1/8	8-7/16
PC 601	38	4-1/16	4-3/8	PC 615	60	8-7/16	8-3/4
PC 602	43	4-3/8	4-11/16	PC 615N (nonsloped)	61	8-3/4	8-3/4
PC 603	43	4-11/16	5	PC 615H (nonsloped 24")	30	8-3/4	8-3/4
PC 604	44	5	5-5/16	PC 616	61	8-3/4	9-1/16
PC 605	45	5-5/16	5-5/8	PC 617	62	9-1/16	9-3/8
PC 605N (nonsloped)	46	5-5/8	5-5/8	PC 618	63	9-3/8	9-11/16
PC 605H (nonsloped 24")	22	5-5/8	5-5/8	PC 619	64	9-11/16	10
PC 606	47	5-5/8	5-15/16	PC 620	67	10	10-5/16
PC 607	50	5-15/16	6-1/4	PC 621	68	10-5/16	10-5/8
PC 608	51	6-1/4	6-9/16	PC 622	71	10-5/8	10-15/16
PC 609	52	6-9/16	6-7/8	PC 623	73	10-15/16	11-1/4
PC 610	54	6-7/8	7-3/16	PC 624	75	11-1/4	11-9/16
PC 611	55	7-3/16	7-1/2	PC 625	76	11-9/16	11-7/8
PC 612	56	7-1/2	7-13/16	PC 625N (nonsloped)	77	11-7/8	11-7/8
PC 613	57	7-13/16	8-1/8	PC 625H (nonsloped 24")	38	11-7/8	11-7/8

700 Hardnose and 700 PE Duraguard adds 1-3/16" to A or B

CHANNEL DRAIN



POUR IN PLACE

Plastic Drain

Channel Drains are a economical alternative to precast concrete drains. Light weight and easy to install. UV inhibitors in the grates, channel and component parts prevents fading and cracking from the sun. All plastic grate and channel components are chemically resistant, rust proof and maintenance free. Channel Drains operate on the same principal as a roof gutter. Mini, Spee-D and Micro drains connect like PVC pipe. Pro Series injected Molded Channel have mechanical interlocking joints. The channels easily connect to sewer and drain pipe fittings or SCH 40 pipe and fittings. This system also offers a choice of outlets. Water can be evacuated from the bottom or from the

end of the channel. It eliminates grading a deck surface to a low area. Instead, the deck is gradually sloped in one direction or plane, and the channel drain acts as a perimeter drain to the edge of the slope. Most hardscapes experience more runoff than landscapes due to the lack of water absorption. Channel Drain systems provide more overall open surface area than conventional area grates. Spee-D and Pro Series will handle light automobile traffic at low speeds. Mini and Micro are designed for foot traffic applications only. **For specific load information, contact Masons Supply.**

SPEED-D

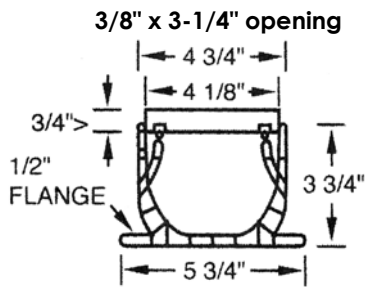

MINI

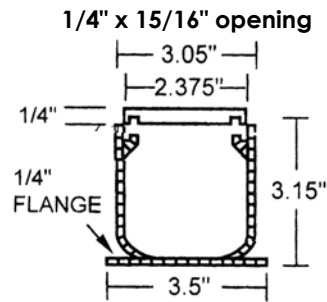

SPEED-D		
No.	Description	Color
NDS 241	2' Grate	Grey
NDS 243	2' Grate	Black
NDS 400	4' Channel	Grey
NDS 401	10' Channel	Grey
ACCESSORIES		
NDS 246	End Outlet w/2" Schedule 40 SPT	Grey
NDS 249	End Outlet w/3" & 4" Offset (Connects to 3" S&D Pipe, 4" S&D Fittings)	Grey
NDS 234	2' Channel w/Fabricated 3" & 4" Spigot (Bottom Outlet with Strainer)	Grey
NDS 247	Solid End Cap	Grey
NDS 248	Coupler	Grey
NDS 2381	90° Elbow Channel	w/Grey Grate
NDS 2301	45° Elbow Channel	w/Grey Grate
NDS 2371	Tee Channel	w/Grey Grate

MINI		
No.	Description	Color
NDS 541	3' Grate	Grey
NDS 500	6' Channel	Grey
Accessories		
NDS 548	Coupler	Grey
NDS 547	Solid End Cap	Grey
NDS 546	End Outlet w/2" Sch. 40	Grey
NDS 550	3' Channel w/2" Sch. 40 Spigot Bottom Outlet	Grey
NDS 5380	90° Elbow Channel	w/Grey Grate
NDS 5300	45° Elbow Channel	w/Grey Grate
NDS 5370	Tee Channel	w/Grey Grate



CHANNEL DRAIN

M A S C O . N E T

POUR IN PLACE

MICRO

No.	Description	Color
NDS 8003	10' Channel Includes (1 Coupler)	Grey
Accessories		
NDS 8653	Channel Clean Out	Grey
NDS 8481	Coupler	Grey
NDS 8473	End Cap	Grey
NDS 8463	End Outlet, w/1-1/2" Sch. 40	Grey
NDS 8503	Bottom Outlet w/ 1-1/2" Sch. 40 Outlet	Grey
NDS 8513	Side Outlet w/ 1-1/2" Sch. 40 Outlet	Grey
NDS 8383	90° Elbow Channel	Grey
NDS 8303	45° Elbow Channel	Grey
NDS 8373	Tee Channel	Grey

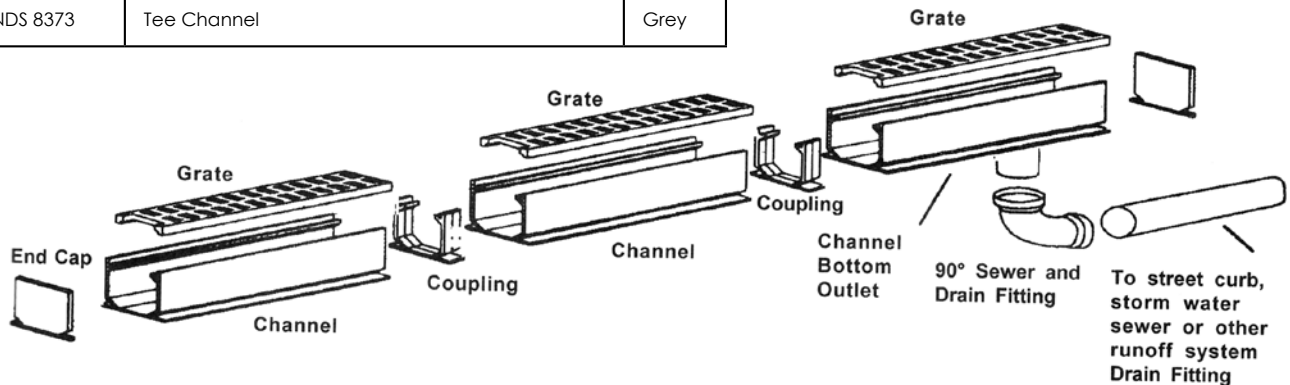
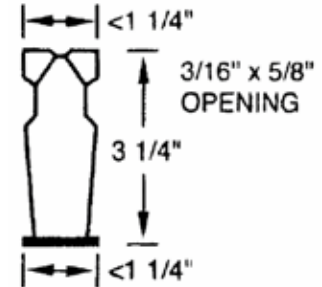

Installation Procedures

1. Locate lowest spot or any area where excess water will accumulate.
2. Dig trench wide enough to allow for 3" of back fill on each side of Spee-D, 2" for Mini Channel, 1" for Micro Channel and 4" for Pro Series. Dig trench deep enough for overall height of channel and grate plus 3" for Spee-d, 2" for Mini, 1" for Micro and 4" for Pro Series. Allow 1/4" recess of grate below surface level for additional drainage.
3. Backfill trench with either concrete or sand and tamp thoroughly. This allows for a level base and provides support. Concrete is always recommended for automobile traffic applications. **(NOTE: Trench bed must be compacted prior to installing channel.)**
4. Measure and cut channel with fine tooth saw to desired length and remove burrs. Assemble channel, using couplings and channel accessories. Test for accurate measurements by placing channel in trench. **(NOTE: You must allow for bottom or end outlets to connect to sewer and drain pipes).**
5. Disassemble channel drain and apply PVC primer and PVC cement to all joints. Reassemble channel joints. Allow cement to dry thoroughly.
6. Install grate on channel. Completely cover grate with duct tape. **(NOTE: Grate must be on channel prior to installation to prevent deflection by concrete).**

WATERSTOP



POUR IN PLACE

PVC

Our PVC Waterstop is made from new materials not reprocessed or reclaimed materials. Unaffected by normal range of concrete or concrete additives. Will not discolor concrete nor produce electrolytic action. Will perform over wide temperature ranges -35° to 175°F. PVC Waterstop is used where concrete is subject to hydrostatic pressure. Provides a positive seal to contain water above or below grade. PVC is most suitable for most common construction. For specific chemical resistance, please call. There are considerations when choosing a waterstop; hydrostatic pressure, wall thickness, type and size of joint, movement and chemical resistance. Dumbbell types and ribbed no center bulb styles are used where no joint movement is expected. Center bulb type can be used in both expansion

and construction joints subject to movement. Split Waterstop allows waterstop to be used easily in bulk head forming. For walls and slabs that are less than 9" thick, typically 4" to 6" waterstop is used. For thickness over 9", typically 9" is used. Waterstop irons must be used for all splicing requirements. See next page for splicing details. There are several important requirements for waterstop joints; Waterstop must be properly located and braced during concrete placement, center bulb on joints. Waterstop must be clean of foreign matter including concrete splatter. Must be properly vibrated and consolidated. Splices must be done right. Factory splices are available on request. Specifications: Corp of Engineers CRD C-572.

No.	Size	Description	Wt/Lf (lbs)	Lf/RL
GS 701	4" x 3/16"	Ribbed Center Bulb Tapered	0.40	100
GS 702	4" x 3/16"	Ribbed Center Bulb	0.74	50
GS 703	6" x 3/16"	Ribbed Center Bulb Tapered	0.73	100
GS 705	6" x 3/8"	Ribbed Center Bulb Tapered	1.19	50
GS 709	9" x 3/8"	Ribbed Center Bulb Tapered	1.63	50
GS 721	4" x 3/16"	Split Ribbed Center Bulb	0.50	100
GS 723	6" x 3/16"	Split Ribbed Center Bulb	0.76	100
GS 724	6" x 3/8"	Split Ribbed Center Bulb	1.54	50
GS 722	9" x 3/8"	Split Ribbed Center Bulb Tapered	1.90	50
GS 732	6" x 3/8"	Ribbed Center Bulb	1.60	50
GS 735	9" x 3/8"	Ribbed Center Bulb	2.45	50
GS 741	4" x 3/16"	Dumbbell	0.47	100
GS 746	6" x 3/16"	Dumbbell	0.71	100
GS 747	6" x 1/4"	Dumbbell	1.07	50
GS 748	6" x 3/8"	Dumbbell	1.51	50
GS 751	9" x 3/8"	Dumbbell	2.18	50
GS 759	6" x 3/8"	Split Dumbbell	1.49	50
Many other sizes available.				

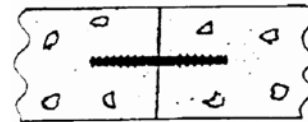

Ribbed Flat Waterstop

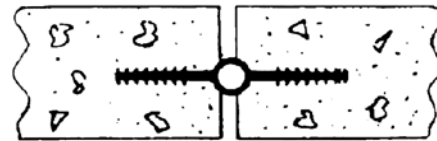

Ribbed with Center Bulb Waterstop

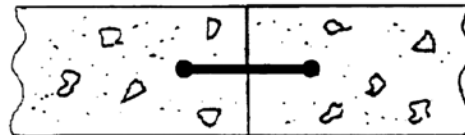

Dumbbell Waterstop

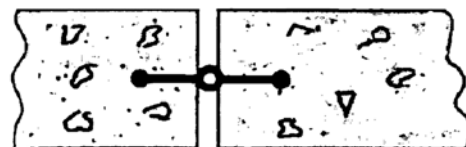

Dumbbell with Center Bulb Waterstop

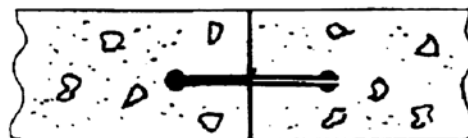

Split Waterstop



WATERSTOP

M A S C O . N E T

POUR IN PLACE

Factory Made Splices Available

- Eliminates intricate field splicing.
- Permits faster waterstop installations.
- Insures correct splicing in critical areas.
- Eliminates guesswork.

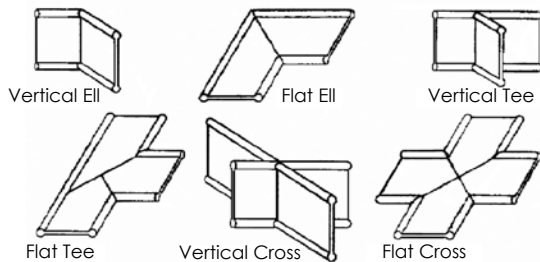

Chemical Resistant

TPE-Rubber Waterstops greatly expand the scope of conventional Waterstops because they do not degenerate under a host of aggressive chemicals, solvents and hot petroleum oils that would destroy PVC. TPE Rubber Waterstops are capable of withstanding joint movement. TPE Rubber Waterstops also have an added advantage of being joined with our regular Waterstop Splicing Irons. The intended use for TPE Rubber Waterstops is for primary and secondary containment facilities where compatibility, resistance and performance values determine the choice based on the specific application test data. TPE Rubber Waterstops are available in 4", 6" and 9" ribbed centerbulb design; which provides for movement within a joint and may be used for above or below grade applications.

No.	Size	Description	Wt/Lf (lbs)
JP 436	4" x 3/16"	Ribbed Center Bulb	0.40
JP 636	6" x 3/16"	Ribbed Center Bulb	0.70
JP 936	9" x 3/16"	Ribbed Center Bulb	1.07



Hog Ring Plier

No.	Wt (lbs)
CT HRP	0.50



Hog Ring

7/8" opening hog rings should be placed at the outer most rib of waterstop 12" on center. Tie off to reinforced steel.

No.	Size
CT HR	#3, 25 lbs/carton (88 pieces/lbs approx)

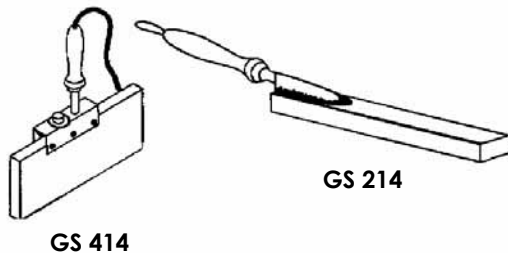

Heating Iron

For PVC Waterstop, cut ends square and hold both sides against iron to 350°- 380° F. Do not allow the iron to reach 400° F, PVC will degrade and turn dark color. When about 1/8" to 1/4" of material becomes soft and gummy, remove the iron and press ends firmly together. Hold tightly and allow material to cool before applying stress. All center bulb waterstop must be aligned. For TPE Waterstop preheat iron to 380° to 410° F. 115 volt, 6 amps, 6' cord.

No.	Size	Wt (lbs)
GS 214	2" x 14"	4.00
GS 214C	2" x 14" Teflon Cover	0.17
GS 414	4" x 14"	8.00
GS 414C	4" x 14" Teflon Cover	0.34

WATERSTOP



POUR IN PLACE

How to make most common spliced sections

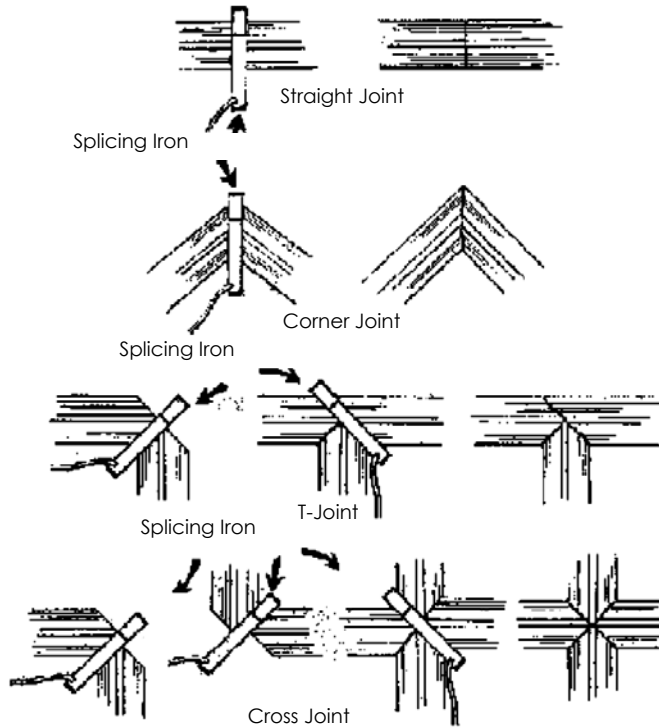

Splicing Technique

A warm-up time of approximately 5 to 10 minutes is necessary to bring the splicing iron to the required 350°-380°F. The entire splicing operation involves three simple steps. Do not allow the iron to reach 400°F. PVC will degrade and turn dark. For TPE Waterstop, preheat iron 380° to 410°F.

Overlap the two pieces of waterstop to be sliced and then cut with sharp knife or saw. This assures matching edges. **IMPORTANT: Edges must be cut straight.**

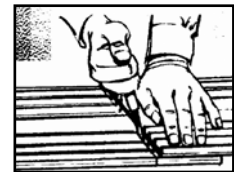

Press the straight cut against the sides of the pre-heated splicing iron until the PVC melts, an 1/8" to 1/4", the material becomes soft and gummy. This takes approximately 3-5 minutes.

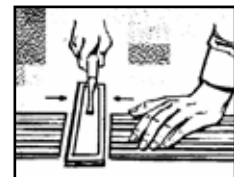

Quickly remove the splicing iron and press the melted edges together to form a neat butt-splice. The joined sections should not be stretched or moved for 1 minute. To cool the material quickly, use cold water. Typical spliced sections and the manner of accomplishing them, are shown above.

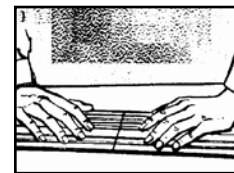



WATERSTOP

M A S C O . N E T

POUR IN PLACE

Bentonite

Waterstop-RX® is a concrete construction joint waterstop that provides a permanent seal by expanding upon contact with water. Waterstop-RX® is an active sodium bentonite based waterstop that is designed to replace conventional passive PVC dumbbell waterstops, thus eliminating the requirement of split-forming and product seam welding.

Waterstop-RX® is manufactured in lightweight, flexible coils that can be installed in both hot and cold weather. The product is adhered to concrete, steel, and PVC (pipes) with **CETSEAL** sealant/adhesive; at or exceeding the required minimum distance from the exterior concrete surface.

The key to Waterstop-RX® is sodium bentonite. Sodium bentonite swells when in contact with water, forming an impermeable barrier. This swelling property allows Waterstop-RX® to form a permanent pressure seal within the concrete joint, thus eliminating water migration over or along the waterstop. In addition to forming a positive pressure seal, the products expansion properties allow it to seal small cracks and void areas.

Waterstop-RX® is designed for structural concrete with a minimum of 3,000 psi. **RX 101** and **101T**, require a minimum 3" of concrete coverage. **RX 102** requires a minimum concrete coverage of 2".

RX 101 and 101T are designed for vertical and horizontal reinforced concrete 8" thick or greater, with two rows of reinforcing steel. RX 101T (trapezoidal) is recommended for shotcrete or gunite concrete construction, extreme hot weather and difficult applications. RX 102 is designed for vertical reinforced concrete 5" thick or greater; and horizontal reinforced concrete 4" thick or greater. RX 102 is designed primarily for concrete with one row of reinforcement.

CETSEAL is a multi-purpose, low VOC, 100% solids, single component polyether moisture cure adhesive used to secure Waterstop-RX® into position. Apply a continuous bead of CETSEAL to substrate then install Waterstop-RX® before CETSEAL skins over and cures within 30 minutes. Adhesive yield will vary with use, substrate and application.

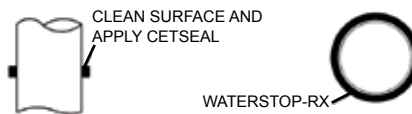
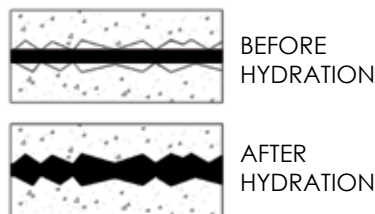
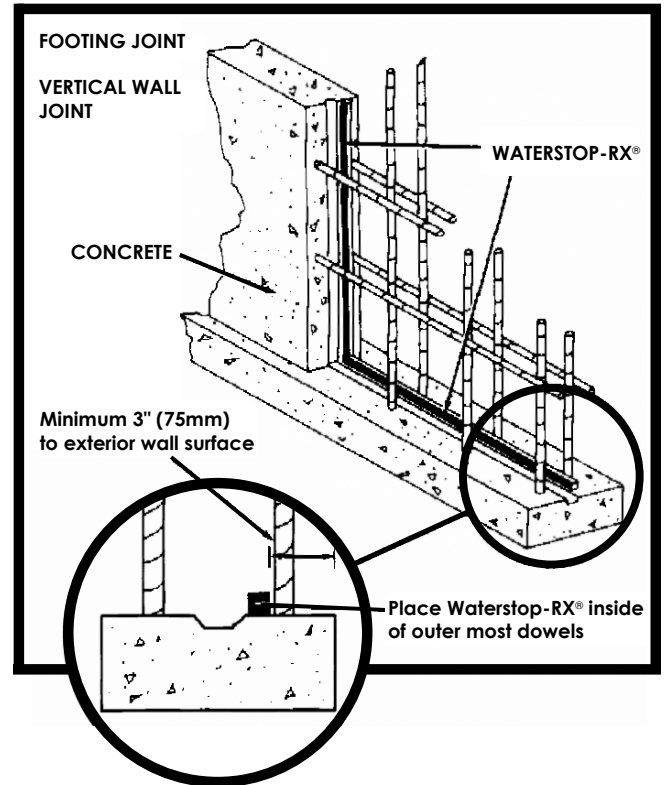

WATERSTOP-RX INSTALLED AROUND ALL APPLICABLE PENETRATIONS

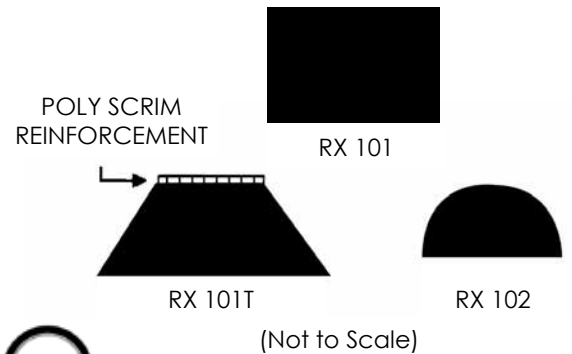

No.	Size	Concrete Thickness	Concrete Cover	Qty/Ctn	Wt/Ctn (lbs)
AC RX101	1" x 3/4"	8" Minimum	3"	100 Lf	53.0
AC RX101T	1-1/4" x 1/2"	8" Minimum	3"	120 Lf	43.0
AC RX102	3/4" x 3/8"	5" to 8" Minimum	2"	200 Lf	34.0
CETSEAL - Sealant/Adhesive					
AC CS	10 oz. Cartridge	10 oz. cartridge yield = approx. 20 Lf		12/case	12.0

WATERSTOP



POUR IN PLACE

Hydrophilic

Hydrophilic waterstop is a chemically modified natural rubber. This patented process chemically binds hydrophilic agent to the rubber. This permits the seal to undergo controlled expansion when in the presence of moisture. This expansion capability provides a "double locking" waterstop. One from rubber's natural resilience and one from the expansion. Any void within the limits of the products volume expansion coefficient, will be filled by the expansion of the seal when it is hydrated. Excellent durability and resistance to chemicals. It can perform in a wide range of solutions such as salt water and cement water. The material does not contain any toxic substance or heavy metals and is environmentally safe.

MC-2010MN

Pre-formed rubber strip with stainless steel net. Used to replace conventional PVC waterstops in construction joints and control joints. Will withstand high hydrostatic head and intermittent exposure to rain or water. Expands up to 2 times by volume. Embedded wire mesh promotes vertical expansion vs longitudinal. Attach with screws, nails, glue, P-201 (may need nails or screws with P-201). Can be used on rough concrete with P-201. NSF certified for potable water.

Minimum Use Conditions:

Wall/slab thickness greater than 9" (10" recommended).
 Minimum 4" concrete coverage - 6.5 ft. wall height (check with Masons for variations).
 Between double row of rebar.
 Below grade or water present either side of wall/slab joint.

No.	Size	Qty/Ctn	Wt/Ctn (lbs)
ADE MC2010MN	20 mm x 10 mm (.78" x .39")	82 lf	17.50

MC-2005M

Pre-formed rubber strip with stainless steel net. Use between joints or structural elements where expected joint opening does not exceed 0.05". Will withstand intermittent exposure to rain or water. Expands up to 2 times by volume. Embedded wire mesh promotes vertical expansion vs longitudinal. Attach with glue or P-201 (may need screws with P-201). Can be used on rough concrete with P-201.

Minimum Use Conditions:

Wall/slab thickness greater than 9" and less than 24".
 Minimum 4" concrete coverage - 6.5 ft. wall height (check with Masons for variations).
 Between double row of rebar.
 Below grade or water present either side of wall/slab joint.
 Hydrostatic head less than 50 ft.

No.	Size	Qty/Ctn	Wt/Ctn (lbs)
ADE MC2005M	20 mm x 5 mm (.79" x .20")	165lf	35.00

Contact Adhesive

2141 Adhesive: is easy-brushing, general purpose rubber adhesive with excellent water resistance. Good for concrete, steel, neoprene, butyl and natural rubber. Surface must be clean, dry and dust free. Apply adhesive to both surfaces and allow to initially dry, typically 5-10 minutes. Press surfaces together. Bond life is up to 15 minutes. Coverage is 82 lf/qt.

No.	Size	Wt (lbs)
ADE Q2141	1Qt	2.50

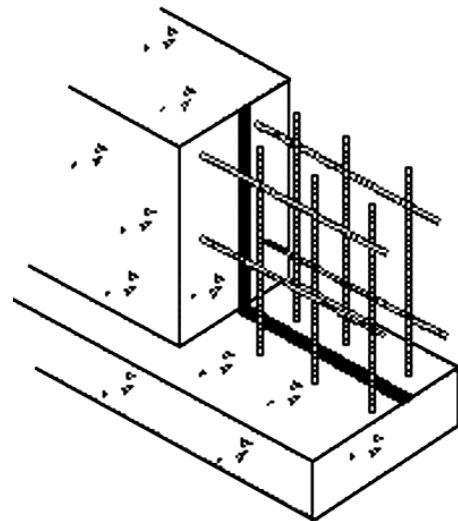

80 Spray Adhesive

Description: Neoprene-based aerosol contact adhesive. Plasticizer resistance. High temp. resistance to 200° F. Fast drying; Fast bonding. Durable - high strength adhesive.

Application: Bond all types of rubber except EPDM. Bond most supported vinyl, leather. Adhere stainless steel panels, stiffeners, and metal kick plates. Adhere many plastics, laminate and wood products. Recommended for bonding ADEKA preformed waterstops.

Coverage: 24 oz. can yields = approx. 75 ff²

No.	Size
TM 80	24 oz. can, 12/case, 13 lbs.

WATERSTOP

POUR IN PLACE

KM-String

Pre-formed string. Used to waterproof sheet piles and cracks where running water is present. String size should be 1.2 times the width of the gap. Size approximately 0.2" ~ 1.6".

KBA-1510FP

Pre-formed rubber strip. Used in non-moving joint where less than 4" of concrete coverage is available. Can be used outside of rebar. Low expansion pressure can be used with limited concrete coverage (2"). Expands approximately 25% by volume. Attach with glue or P-201 (may need screws with P-201). C approximately 0.6" x 0.4".

Minimum Use Conditions:

- Wall/thickness greater than 4".
- Minimum 2" concrete coverage.
- Can be used with single row of rebar or double row of rebar.
- Below grade or water present either side of wall/slab joint.
- Hydrostatic head less than 25 ft.

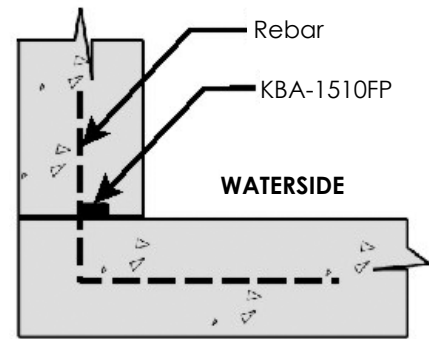

No.	Size	Qty/Ctn	Wt (lbs)
ADE KBA1510FP	15mm x 10mm (.59" x .39")	82 lf	8.0

P-201 Cartridge

A single component hydrophilic compound used in water and repair applications. It can be placed on damp or uneven surfaces and functions in a wide range of temperature ground water conditions. P-201 is used in pipe penetrations, preventing water penetration in sheet piles, pre-cast concrete joints, and a variety of joint and crack repair applications. P-201 is used in conjunction with formed Adeka waterstops whenever damp or rough surfaces are encountered. Expansion rate of P-201 is 80%. 6 per case. See technical bulletin for more information.

Minimum Use Conditions:

- Wall/slab thickness greater than 6".
- Pipe diameter greater than 2" and less than 24" (check with Masons for exceptions).
- Typical bead size 3/8" x 1/2".
- Will withstand high hydrostatic head.
- Must be cured before placing concrete.
- Curing time dependent upon temperature and humidity.
- Minimum 2-1/2" concrete coverage.

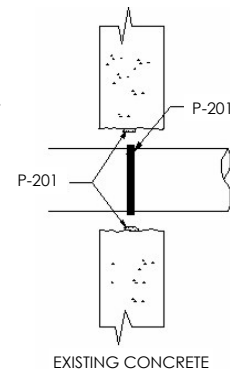

No.	Size	Wt (lbs)
ADE P201	11 fl oz. cartridge	1.20

A-30

A-30 is a liquid rubber has a high expansion rate when it comes in contact with water. Used to fill the gaps of interlocking sheet pile. See technical bulletin for more information.

No.	Size	Wt (lbs)
ADE A30	4.0 gal. pail	50.0

