

GLOBE 600 BRONZE

200 lb. SWP-400 lb. WOG† • Flow Control • Needle Point Bronze Stem
Threaded Bonnet • Gland Packed • Threaded Ends

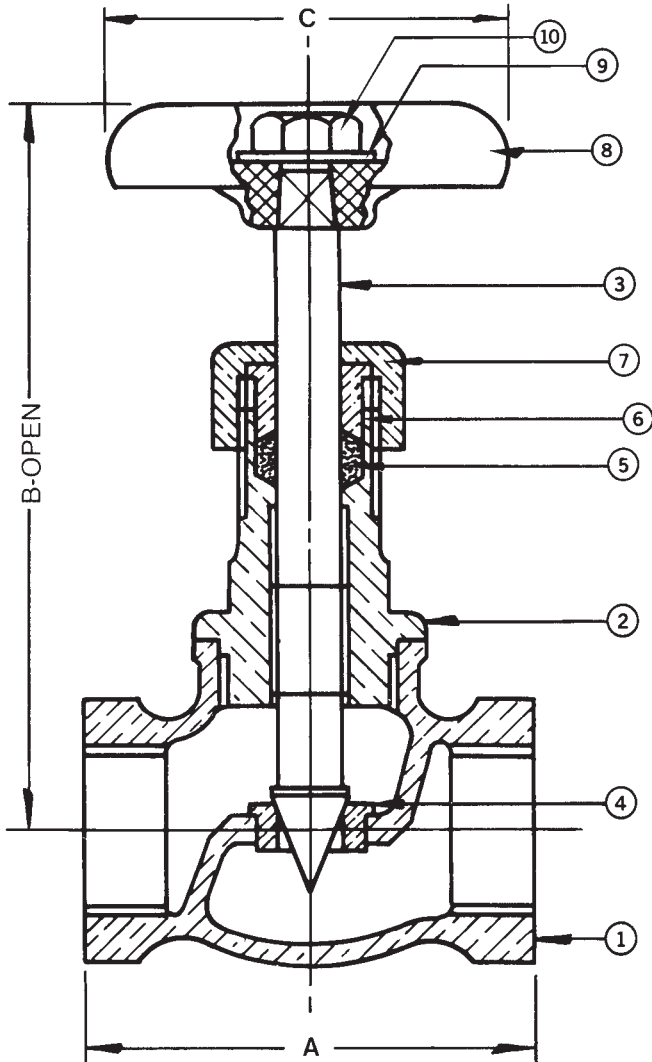

MATERIAL LIST

NO.	PART	MATERIAL	SPECIFICAION
1	Body	Bronze	ASTM B 61
2	Bonnet	Bronze	ASTM B 61
3	Stem	Bronze	ASTM B 61
4	Seat Ring (Pressed In)	Brass	ASTM B 16
5	Packing	Graphite	
6	Gland	Brass	ASTM B 124 C37700
7	Packing Nut	Brass	ASTM B 283 C37700
8	Handwheel	Mall. Iron	Commercial
9	Identification Plate	Aluminum	Commercial
10	Handwheel Nut	Brass	Commercial

DIMENSIONS - INCHES / MILLIMETERS

Units	Size	A	B	C
Inches	1/8	1.63	3.19	2.00
mm	3.18	41.28	80.98	50.80
Inches	1/4	1.63	3.19	2.00
mm	6.35	41.28	80.98	50.80
Inches	3/8	1.81	3.19	2.00
mm	9.53	46.05	80.98	50.80
Inches	1/2	2.31	3.63	2.00
mm	12.70	58.75	92.08	50.80
Inches	3/4	2.56	3.94	2.25
mm	19.05	65.10	100.03	57.15

† Non-Shock

Rev. 4

INNOVATION IN EVERY VALVE



MILWAUKEE VALVE

The information presented on this sheet is correct at the time of publication. Milwaukee Valve reserves the right to change design, and/or material specifications without notice. For the Installation, Operation and Maintenance Manual (IOM) see the engineering section on our website. For the most current information access www.milwaukeevalve.com

www.milwaukeevalve.com