

Model: 758

Cast Iron Flanged Ends Y Strainers Sizes: 3/4" - 24" (20 - 600mm)

Pressure/Temperature - Non-Shock		
Size	Material	Rating
3/4"-12"	Cast Iron	200psi @ -20 to 150°F
		13.79 bar @ 65.56°C
		125psi @ 450°F
14"-24"	Cast Iron	8.62 bar @ 232.22°C
		150psi @ -20 to 150°F
		10.34 bar @ 65.56°C
		100psi @ 353°F
		6.89 bar @ 178.33°C

758

Class 125



Model 758

Typical Service

- Used extensively to strain foreign matter from pipe lines and provide economical protection for costly pumps, meters, valves, and other similar mechanical equipment

Features

- Mueller "BREECH-LOK STRAINERS" furnished as standard in sizes 8" and larger.
 - A one-quarter turn securely locks the screen in its seat.
 - Allows for easy bolting of the cover flange.
 - Tapered seats in both the body and cover flange retain screen and prevent particle bypass

Construction

- All covers have NPT blowoff outlet at location C. See next page.
- Recessed seat in the cover assures accurate screen alignment.
- Bosses at the inlet and outlet flanges are provided for the gauge taps.

Self-cleaning

- Self-cleaning is accomplished by opening the plug or valve connected to the blowoff outlet
- Advise when strainers are to be mounted in vertical piping so we can rotate the cover to position the blowoff at the lowest point.

Blowoff Outlets

- Outlets are NPT tapped
- Sizes of tapping specified on next page.
- Not normally furnished with plug. Plug available, specify with order

Capacity

- Generously proportioned bodies
- Open Area Ratio much greater than pipe size, ensuring low pressure drop

Screens

MODEL	SIZES	STANDARD (WATER)		STEAM RECOMMENDATION	
		MATERIAL	OPENING	MATERIAL	OPENING
758	3/4" - 4"	304SS	.062 perf	304SS	.045 perf
758	5" - 10"	304SS	.125 perf	304SS	.045 perf
758	12" and Up	304SS	.125 perf	304SS	.062 perf

Job Name _____

Job Location _____

Engineer _____

Approval _____

Contractor _____

Approval _____

Contractor's P.O. No. _____

Representative _____

Material

758	
Body	Cast Iron ASTM A126-B
Cover	Carbon Steel ASTM A126-B
Gasket	Compressed Fiber

Consult factory for other materials.

Pressure Drop

- See Pressure Drop Charts in Technical Data section of the Mueller Steam Specialty Engineering binder.

Dimensions and Weights

SIZE		DIMENSIONS								WEIGHT	
		A		B		C (NPT)		D Screen Removal			
in.	mm	in.	mm	in.	mm	in.	mm	in.	mm	lbs.	kgs.
¾	20	7⅞	187	3¾	95	½	15	5	127	10	4.5
1	25	7⅞	187	3⅞	98	½	15	5	127	10	4.5
1¼	32	7½	190	4¾	120	½	15	6½	165	13	5.9
1½	40	7½	190	4¾	120	½	15	6½	165	13	5.9
2	50	7⅞	200	5¼	133	½	15	7	178	18	8
2½	65	10	254	6½	165	1	25	9¾	248	28	12
3	80	10⅞	257	7	178	1	25	10	254	34	15
4	100	12⅞	308	8¼	210	1½	40	12	305	60	27
5	125	15⅝	397	11¼	286	2	50	17	432	95	43
6	150	18½	470	13½	343	2	50	20	508	133	60
8	200	21⅞	549	15½	394	2	50	22¾	578	247	112
10	250	25¾	654	18½	470	2	50	28	711	370	168
12	300	29⅞	759	21¾	553	2	50	30	762	579	263
14	350	33¼	846	25	635	2	50	36½	927	863	392
16	400	38¾	984	26½	673	2	50	42	1067	1380	627
18	450	43⅞	1105	31	788	2	50	45½	1156	2272	1032
20	500	49½	1257	38⅜	970	2	50	55⅞	1407	2675	1213
24	600	58½	1486	44⅜	1119	2	50	67¼	1708	4880	2213

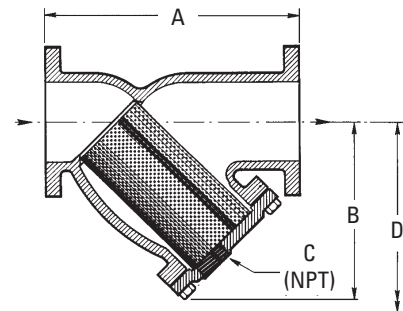

Model 758

Apply For Certified Drawings.

Mueller Steam Specialty product specifications in U.S. customary units and metric are approximate and are provided for reference only. For precise measurements, please contact Mueller Steam Specialty Technical Service. Mueller Steam Specialty reserves the right to change or modify product design, construction, specifications, or materials without prior notice and without incurring any obligation to make such changes and modifications on Mueller Steam Specialty products previously or subsequently sold.



A Watts Water Technologies Company



USA: St. Pauls, NC • Tel. 1-800-334-6259 • Fax 1-800-421-6772 • www.muellersteam.com