

# Class 125 Iron Body Gate Valves

Bolted Bonnet • Outside Screw and Yoke • Solid Wedge • Bronze Mounted

**125 PSI/8.6 Bar Saturated Steam to 353° F/178° C**  
**200 PSI/13.8 Bar Non-Shock Cold Working Pressure**  
**to -20° F to 150° F/-29° C to 66° C**◆

CONFORMS TO MSS SP-70

## MATERIAL LIST

PART	SPECIFICATION
1. Stem	Brass ASTM B 16 Alloy C36000
2. Handwheel Nut	Cast Bronze ASTM B 584 Alloy C84400
3. Identification Plate	Aluminum
4. Yoke Bushing	Cast Bronze ASTM B 584 Alloy C84400
5. Handwheel	Cast Iron ASTM A 126 Class B
6. Bonnet Cap Nut	Steel ASTM A 307
7. Bonnet Cap	Cast Iron ASTM A 126 Class B or Ductile Iron ASTM A 536
8. 1 Bonnet	Cast Iron ASTM A 126 Class B
9. Bonnet Cap Bolt	Steel ASTM A 307
10. Gland Follower Nut	Brass ASTM B 16 Alloy C36000
11. Gland Follower	Cast Iron ASTM A 126 Class B or Ductile Iron ASTM A 536
12. Packing Gland	Zinc Plated Powdered Iron ASTM B 783 or Brass ASTM B 16 Alloy C36000
13. Packing	Synthetic Fibers with Graphite
14. Gland Follower Bolt	Steel ASTM A 307
15. Backseat Bushing	Cast Bronze ASTM B 584 Alloy C84400
16. Body Nut	Steel ASTM A 307
17. Body Bolt	Steel ASTM A 307
18. Wedge Pin	Silicon Bronze ASTM B 371 Alloy C69400 (10" & 12") or B 140 Alloy C31600 (2"-8")
19. Body	Cast Iron ASTM A 126 Class B
20. Seat Ring	Cast Bronze ASTM B 584 Alloy C84400
21. Wedge Face Ring	Cast Bronze ASTM B 584 Alloy C84400
22. 2 Wedge	Cast Iron ASTM A 126 Class B
23. Body Gasket	Synthetic Fibers
24. Stem Collar	Brass ASTM B 16 Alloy C36000

<sup>1</sup>Sizes thru 8" made with Yoke Integral with Bonnet. 10" and 12" sizes made with separate Yoke Bolted to Bonnet.

<sup>2</sup>Sizes 2" thru 6" are all Bronze Wedges. Sizes 8" thru 12" made with Cast Iron Wedge with Bronze Wedge Face Rings.

## DIMENSIONS—WEIGHTS—QUANTITIES

Dimensions																	
Size	F-617-O		T-617-O		B	C	D	E	F-617-O		T-617-O						
	A	A	A	A					Lbs.	Kg.	Lbs.	Kg.					
In.	mm.	In.	mm.	In.	mm.	In.	mm.	In.	mm.	Lbs.	Kg.	Lbs.	Kg.				
2	50	7.00	178	5.63	143	16.31	414	8	203	6.00	152	.63	16	41	19	30	14
2½	65	7.50	191	5.88	149	17.19	437	8	203	7.00	178	.69	17	55	25	39	18
3	80	8.00	203	6.13	156	19.50	495	8	203	7.50	191	.75	19	67	30	47	21
4	100	9.00	229	6.50	165	24.00	610	10	254	9.00	229	.94	24	107	48	77	35
5	125	10.00	254	x	x	27.13	689	10	254	10.00	254	.94	24	145	66	x	x
6	150	10.50	267	x	x	31.06	789	12	305	11.00	279	1.00	25	178	81	x	x
8	200	11.50	292	x	x	40.19	1021	14	356	13.50	343	1.13	29	309	140	x	x
10	250	13.00	330	x	x	48.25	1226	16	406	16.00	406	1.19	30	481	218	x	x
12	300	14.00	356	x	x	56.88	1445	18	457	19.00	483	1.25	32	706	320	x	x

x Not available this size.



**F-617-O**  
Flanged



**T-617-O**  
Threaded

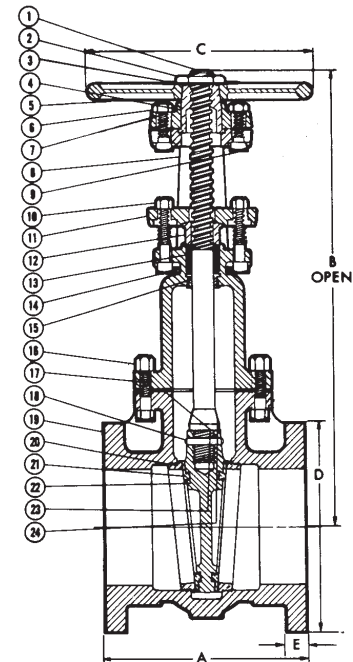

**F-617-O**  
Flg x Flg

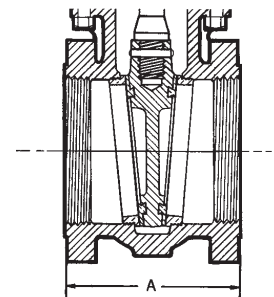

**T-617-O**  
NPT x NPT

**FREEZING WEATHER PRECAUTION:** Subsequent to testing a piping system, valves should be left in an open position to allow complete drainage.

Position indicators available, see page 95.

◆ For detailed Operating Pressure, refer to Pressure Temperature Chart on page 111.