

Class 125/250 Iron Body Silent Check Valves

Flanged • Globe Style • Renewable Seat and Disc • Spring Actuated (1/2 Cracking Pressure)

Class 125, 200 PSI/13.8 Bar Non-Shock Cold Working Pressure
Class 250, 400 PSI/27.6 Bar Non-Shock Cold Working Pressure
Maximum Temperature to 200° F/93° C

CONFORMS TO MSS SP-125 •
CONFORMS TO MIL-V-18436F
FM APPROVED — 2½" thru 10" ONLY (F910B)

MATERIAL LIST

PART	SPECIFICATION
1. Body	Cast Iron ASTM 126 Class B
2. Seat	Bronze ASTM B 584 Alloy C83600 (B)
2a. Seat	Buna-N Bonded to Bronze (W)
3. Disc	Bronze ASTM B 584 Alloy C83600
4. Spring	Stainless Steel Type 316 ASTM A 313
5. Bushing	6" and smaller ASTM B 16 8" and larger ASTM B 584 C83600
6. Set Screws	Stainless Steel Type 304

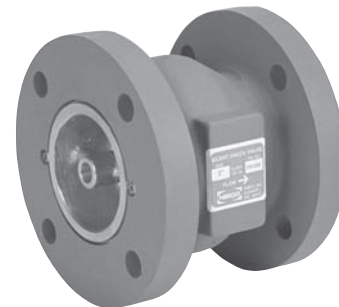

F-910, 125 lb. Class
F-960, 250 lb. Class
Flanged

DIMENSIONS—WEIGHTS—QUANTITIES

Size	Dimensions		F-910		F-960	
	In.	mm.	Lbs.	Kg.	Lbs.	Kg.
2½	65	5.50	24	11	30	14
3	80	6.00	29	13	36	16
4	100	7.25	42	19	59	27
5	125	8.50	52	24	78	35
6	150	9.75	73	33	103	47
8	200	12.50	126	57	179	81
10	250	15.50	1205	93	253	115
12	300	14.25	306	139	401	182
14	350	15.75	400	172	511	232
16	400	17.63	448	202	697	316
18	450	18.75	476	216	959	435
20	500	20.63	524	238	1180	535
24	600	24.00	610	276	1680	762
30	750	29.25	743	336	2375	1077
36	900	45.00	1143	518	2005	2500

x Not available these sizes.

NOTE: F-910 made to 125 lb. Flange dimensions.

F-960 made to 250 lb. Flange dimensions.

A Wafer Style Butterfly Valve can be mated on the down stream side of the F-910 2½"-10" sizes without use of spacers or adapters. 316 Stainless Steel Trim available – Consult Factory.

USE THIS VALVE ONLY WITH FLAT FACE FLANGE AND FULL FACE GASKET.

- WARNING:
1. Seat end of valve must be mated to a standard flat faced metal flange. Rubber flanges not acceptable.
 2. These are not to be used as steam valves.
 3. Valves are not to be used near a reciprocating air compressor.
 4. Install 5 pipe diameters minimum downstream from pump discharge or elbows to avoid flow turbulence. Flow straighteners may be required in extreme cases.

Note: On pump discharge, the preferred check valves are:

- inline, spring assisted, center-guided, lift checks
- spring assisted twin (double) disc
- swing design with lever and weight or lever and spring

You should also install the check valve as far from the pump as possible and at a minimum length of 5 times the pipe diameter. Flow straighteners may be required.

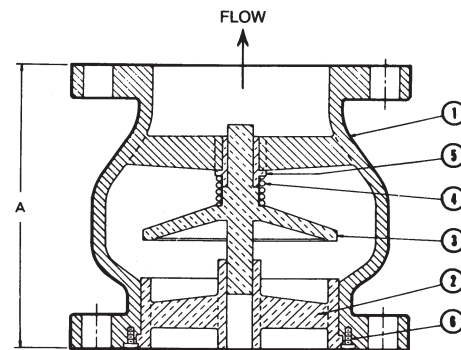

F-910-B or F-960-B
Flg x Flg Flg x Flg

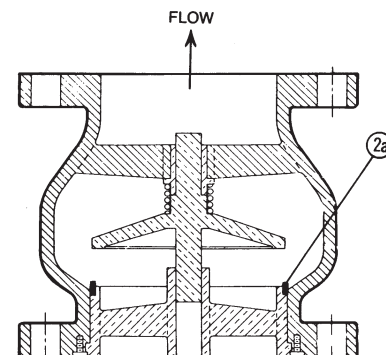

F-910-W or F-960-W
Flg x Flg Flg x Flg

◆ For detailed Operating Pressure, refer to Pressure Temperature Chart on page 111.