



CARBON & STAINLESS STEEL

BALL VALVE

580-CS/S6 & 595-CS/S6

APPLICATIONS

The NIBCO 580-CS/S6 and 595-CS/S6 series two and three piece ball valves provide exceptional performance and value for general service and industrial applications:

- Chemical
- Steam
- Water (Hot and Cold)
- Hydraulics
- Petroleum

MATERIALS & CONSTRUCTION

- Carbon and/or stainless steel construction
- Reinforced PTFE seats
- Carbon filled PTFE seals/packing
- Actuator mounting pad standard on TM/KM-595 and T580-S6
- Locking handle standard on T580-S6 and T/K-595 series
- Three piece design allows in-line maintenance and welded installation.

DESIGN CRITERIA

- Two and three piece valves conform to the requirements of MSS SP-110
- Threaded ends per ANSI B1.20.1
- Socket weld ends per ANSI B16.11
- Markings are in accordance with MSS SP-25
- All valves are equipped with a grounding device.



T580-S6-R-66-LL

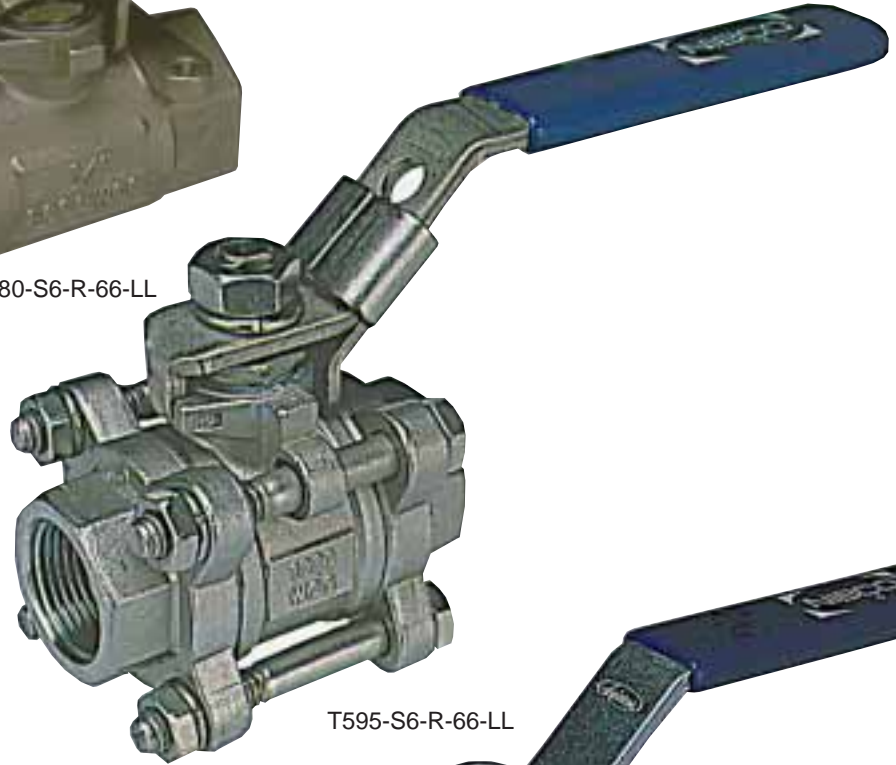

T595-S6-R-66-LL



TM595-CS-R-66

580-CS/S6 & 595-CS/S6 FIGURE NO. KEY

EXAMPLE: T - 580 - S6 - R - 66 - LL

End Connection	Series	Body Style	Seat Material	Trim	Handle Option
T = Threaded	580 - 2 piece	S6 = Stainless Steel	R = Reinforced PTFE	66 = Stainless Steel Ball & Stem	LL=Locking Lever
K = Socket Weld	595 - 3 piece	CS = Carbon Steel		25=Carbon Steel Ball & Stem	*OV=Oval Handle
TM=Thrd W/Mt. pad					
KM=Skt Wld W/Mt. pad					*Field retrofit Option

T-580-CS BALL VALVE



SPECIFICATIONS

**Two Piece, Threaded, Carbon Steel body, PTFE Seats, Carbon & Stainless Trim,
2000 psi CWP**



T580-CS-R-66
Stainless Steel Trim
T580-CS-R-25
Carbon Steel Trim

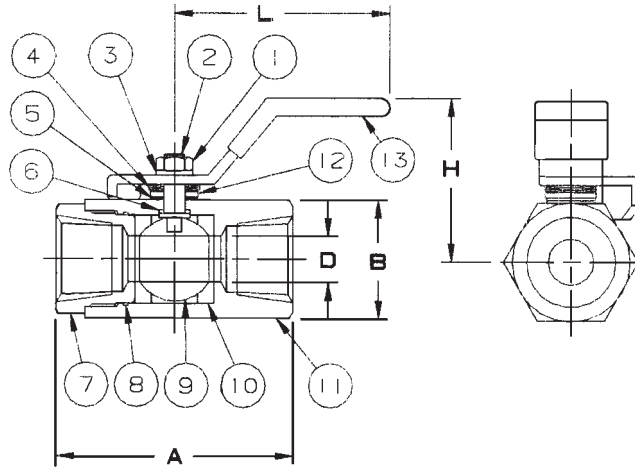

Material List

	QTY	PARTS	SPECIFICATIONS	
			CS TRIM	SS TRIM
1.	1	Lock Nut	A283 CS	A283 CS
2.	1	Stem	1045 CS	316 SS
3.	1	Spring Washer	CS	CS
4.	2	Belleville Washer	CS	CS
5.	2	Thrust Washer	PTFE	PTFE
6.	1	Stem Seal	Carbon filled PTFE	Carbon filled PTFE
7.	1	Body Cap	AISI 1018	AISI 1018
8.	1	Spacer Seal	PTFE	PTFE
9.	1	Ball	304 SS	316 SS
10.	2	Seat	RTFE	RTFE
11.	1	Body	AISI 1018	AISI 1018
12.	1	Plate Washer	A283 CS	A283 CS
13.	1	Handle	A283 CS	A283 CS

Dimensions/Weight Table - Inches

SIZE	A	B	D	H	L	LBS.	BOX QTY.
1/4"	2.30	1.02	0.38	2.22	4.13	0.64	10
3/8"	2.30	1.02	0.38	2.22	4.13	0.59	10
1/2"	2.52	1.26	0.38	2.44	4.13	0.86	10
3/4"	2.95	1.61	0.50	2.64	4.13	1.52	10
1"	3.35	1.97	0.69	2.83	5.83	2.57	10
1 1/4"	3.66	2.17	1.00	2.97	5.83	3.23	5
1 1/2"	4.11	2.64	1.25	3.25	7.17	5.08	5
2"	4.61	3.03	1.50	3.54	7.28	7.13	5

* 1/4" - 1" 2000 psi CWP, 1 1/4" - 2" 1500 psi CWP