

# Class 125 Bronze Globe Valves

Screw-in Bonnet • Integral Seat • Renewable Seat and Disc

**125 PSI/8.6 Bar Saturated Steam to 353° F/178° C**  
**200 PSI/13.8 Bar Non-Shock Cold Working Pressure**

CONFORMS TO MSS SP-80

## MATERIAL LIST

PART	SPECIFICATION
1. Handwheel Nut	300 Series Stainless Steel
2. Identification Plate	Aluminum
3. Handwheel	Malleable Iron ASTM A 47
4. Stem	Silicon Bronze ASTM B 371 Alloy C69400/C69430
5. Packing Gland	Bronze ASTM B 62 or ASTM B 584 Alloy C84400 or Brass ASTM B 16
6. Packing Nut	Bronze ASTM B 62 or ASTM B 584 Alloy C84400 or Brass ASTM B 16
7. Packing	Aramid Fibers with Graphite
8. Bonnet	Bronze ASTM B 62
9. Disc Holder Nut	Bronze ASTM B 140 Alloy C31400 or B 62
*10. Disc Holder	Bronze ASTM B 62
*11. Seat Disc	Water, Oil or Gas Steam (PTFE) (Y)
*11a. Seat Disc	Bronze ASTM B 62 (B)
*12. Disc Nut	Bronze ASTM B 62/ASTM B 98 Alloy C65100 w/SS Washer
13. Body	Bronze ASTM B 62

Note: S-211 not available with (B) Disc.

\* The Bronze Disc does not require a Disc Nut. When converting from (B) Disc to (Y) Disc, order Disc Nut (12) and Disc Holder (10) and proper disc (11).

## DIMENSIONS—WEIGHTS—QUANTITIES

Size	Dimensions						T-211		S-211		Master Ctn. Qty.		
	In.	mm.	In.	mm.	In.	mm.	Lbs.	Kg.	Lbs.	Kg.	T-211	S-211	
*1/8†	6	2.38	60	3.38	86	1.81	46	1.01	0.46	0.98	0.44	50	50
*1/4†	8	2.38	60	3.38	86	1.81	46	1.00	0.45	0.94	0.43	50	50
*3/8†	10	2.38	60	3.38	86	1.81	46	0.98	0.45	0.93	0.42	50	50
*1/2†	15	2.56	65	3.38	86	1.69	43	1.03	0.47	0.95	0.43	50	50
3/4	20	3.06	78	4.88	124	2.25	57	1.73	0.79	1.80	0.82	30	30
1	25	3.69	94	5.69	145	2.81	72	2.85	1.29	2.87	1.30	20	20
1 1/4	32	4.31	110	6.13	156	3.06	78	3.79	1.72	3.55	1.61	10	10
1 1/2	40	4.69	119	7.38	187	3.56	91	5.90	2.68	5.70	2.58	10	10
2	50	5.63	143	7.94	202	4.44	113	8.68	3.94	8.91	4.04	6	4
2 1/2	65	6.63	168	10.19	259	5.25	133	15.40	6.98	15.92	7.22	2	2
3	80	7.75	197	11.19	284	6.50	165	22.44	10.18	21.32	9.67	2	2

\* Stem and Disc (or Disc Holder) are integral.

† No packing gland, packing only in these sizes.

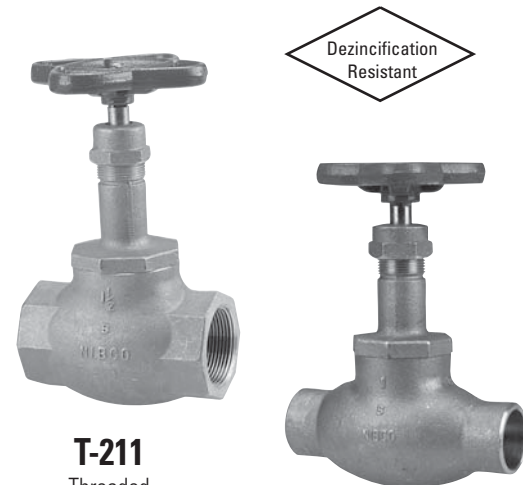

**T-211**  
Threaded

**S-211**  
Solder

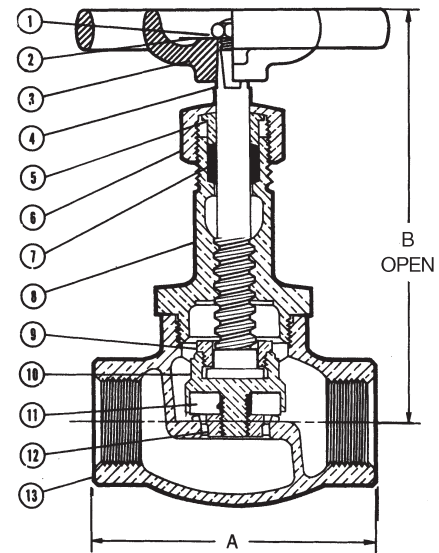

**T-211-Y**  
NPT x NPT

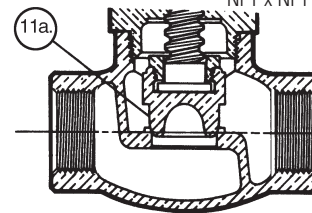

**T-211-B**  
NPT x NPT

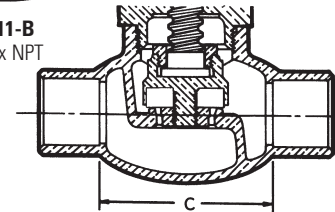

**S-211-Y**  
C x C

Freezing Weather Precaution – Subsequent to testing a piping system, valves should be in an open position to allow complete drainage.

♦ For detailed Operating Pressure, refer to Pressure Temperature Chart on page 111.