

Class 125 Bronze Check Valves

Horizontal Swing • Regrinding Type • Y-Pattern •
Renewable Seat and Disc

125 PSI/8.6 Bar Saturated Steam to 353° F/178° C
200 PSI/13.8 Bar Non-Shock Cold Working Pressure

CONFORMS TO MSS SP-80

MATERIAL LIST

PART	SPECIFICATION
1. Bonnet	Bronze ASTM B 62
2. Body	Bronze ASTM B 62
3. Hinge Pin	Bronze ASTM B 140 Alloy C31400 or B 134 Alloy C23000
4. Disc Hanger	Bronze ASTM B 62 or 304 Stainless Steel ¼" thru ¾" sizes
5. Hanger Nut	Bronze ASTM B 16
6. Disc Holder	Bronze ASTM B 62
7. Seat Disc	Water, Oil or Gas (Buna-N) (W) Steam (PTFE) (Y) Bronze ASTM (B) FKM (V) B 62 C83600
8. Seat Disc Nut	Bronze ASTM B 16 or B 62
9. Hinge Pin Plug	Bronze ASTM B 140 Alloy C31400 (not shown)
*10. Seat Disc Washer	ASTM B 98 Alloy C65500 or ASTM B 103

* Sizes ¾", 1", 1¼", 1½" and 2" only.

DIMENSIONS—WEIGHTS—QUANTITIES

Size	Dimensions						T-413		S-413		Master Ctn. Qty.	
	A		B		C		Lbs.	Kg.	Lbs.	Kg.		
In.	mm.	In.	mm.	In.	mm.	In.	mm.	Lbs.	Kg.	Lbs.	Kg.	
¼	8	2.13	54	1.63	41	1.38	35	0.50	0.23	0.51	0.23	50
⅜	10	2.13	54	1.63	41	1.31	33	0.47	0.22	0.48	0.22	50
½	15	2.44	62	1.69	43	1.50	38	0.55	0.25	0.55	0.25	50
¾	20	2.94	75	1.88	48	1.88	48	0.90	0.41	0.88	0.40	50
1	25	3.56	90	2.31	59	2.25	57	1.46	0.66	1.48	0.67	30
1¼	32	4.19	106	2.69	68	2.75	70	2.17	0.99	2.22	1.01	20
1½	40	4.50	114	2.94	75	1.13	79	2.95	1.34	3.00	1.36	10
2	50	5.25	133	3.94	100	3.75	95	4.79	2.17	4.87	2.21	10
2½*	65	8.00	203	5.06	129	5.06	129	11.48	5.21	10.48	4.76	5
3*	80	9.25	235	6.25	159	6.25	159	17.53	7.96	15.29	6.94	4

Ordering: T-413 and S-413 normally furnished with Bronze Disc (T-413-B) or (S-413-B).
Both available with PTFE Steam Disc (T-413-Y), (S-413-Y), or CWP Disc (T-413-W),
(S-413-W) or 300° F 67 PSI steam FKM Disc (T-413-V).

* - Class 150 (433) furnished for these sizes.

For detailed Operating Pressure, refer to Pressure Temperature Chart on page 111.

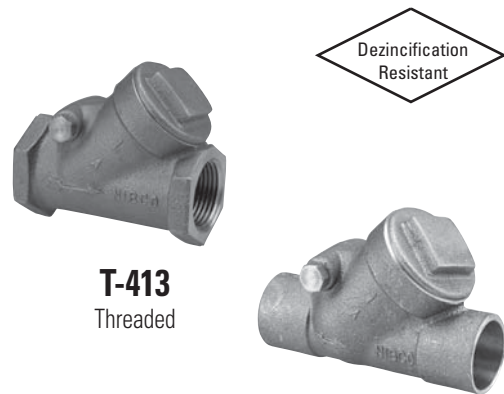

T-413
Threaded

S-413
Solder

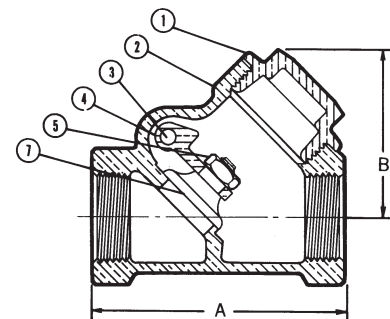

T-413-B
NPT x NPT

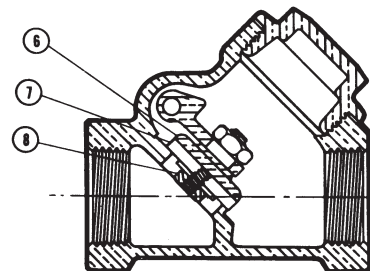

T-413-Y
NPT x NPT

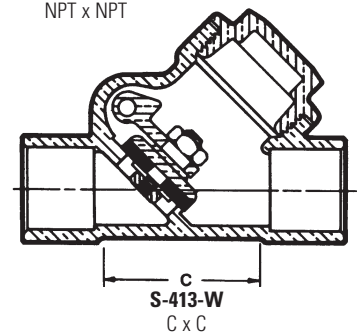

S-413-W
C x C

NIBCO check valves may be installed in both horizontal and vertical lines with upward flow or in any intermediate position. They will operate satisfactorily in a declining plane (no more than 15°).

Warning - Do Not Use For Reciprocating Air Compressor Service.