



September 2009

BUILDING CONNECTIONS THAT LAST



Steel Pipe Nipples & Malleable Fittings



Anvil's Unmatched Piping Products for Every Industry

Anvil provides the most comprehensive line of innovative, durable, and reliable pipe connections, support systems, and customer service.

For more than 150 years, Anvil has provided integrated, reliable piping solutions for a variety of applications. With the most complete line of piping products, expert design services, and a responsive customer service team, Anvil's total package is unmatched throughout the industry. Our professionals will work with you to develop innovative solutions that meet your demands and exceed your expectations.



From HVAC, plumbing and mechanical to fire protection, mining, oil and gas, and gas utilities, Anvil covers all markets. Our extensive product line includes grooved couplings, fittings, and valves; cast and malleable pipe fittings; forged steel fittings and unions; steel pipe nipples and couplings; pipe hangers and supports; strut and channel; oil country fittings; and valves. Our exceptional market-specific expertise ensures you always get the best solution for your unique application.

In addition to Anvil's extensive line of domestically manufacture products, Anvil also offers a full line of Globally manufactured malleable iron fittings and steel pipe nipples. These products are manufactured within ISO 9001:2000 facilities where Anvil's quality control engineers oversee the entire process. Anvil is committed to providing the finest quality pipe fittings available, which we believe only a true manufacturer can provide. Engineered drawings of fittings and nipples along with detailed inspection procedures, leave no questions regarding Anvil's commitment to quality imported products.

With 150 years of manufacturing expertise, Anvil is in a unique position to set the highest quality standard for both domestic and import products. Anvil's specifications for SPF malleable fittings and pipe nipples are higher than typical ANSI specification. The SPF malleable fittings are UL Listed and FM Approved.

Standard Welded

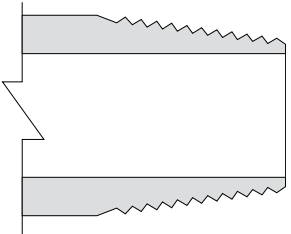
Anvil International is the only manufacturer where you can combine your import and U.S. Manufactured product requirements.

| STANDARDS & SPECIFICATIONS | | SPF Imported Steel Pipe Nipples (Standard Welded) | |
|----------------------------|---------------------------|--|---|
| Dimensional: | ASTM A733 | <p>Standard End Finish Tapered Pipe Thread (NPT)</p>  |  |
| Material: | ASTM A53 Type F or Type E | | |
| Galvanizing: | Hot Dip Galvanizing* | | |
| Threading:** | ASME B 1.20.1 | | |

*Galvanized nipples are manufactured from pipe coated on the inside and outside by hot dip process.

**British Standard threading per BS 21 available upon request.

- Ends are cut square to the central axis. All burrs on the inside are removed. The ends of the pipe nipples are chamfered on the outside at an angle of 35° +/- 10° to the central axis.
- Pipe nipples are threaded on both ends with standard NPT tapered threads. Threads are right hand on both ends.

Also available:



- Ready Cut Pipe, Standard - Schd. 40 (black and galvanized)
Pipe Size: 1/2", 3/4", 1", 1 1/4", 1 1/2", 2"
Pipe Length: 8", 24", 30", 48", 60", 72"
- "66" Packs, Standard - Schd. 40 (black and galvanized)
Nipple Size: 1/2", 3/4", 1", 1 1/4", 1 1/2", 2"
- Single Run Nipple Packs (black and galvanized)
Pipe Size: 1/2", 3/4", 1, 1 1/4", 1 1/2", 2"

| Pipe Size (in.) | Pipe O.D. (in.) | Length Close (in.) | Pipe Nipple Lengths (Black and galvanized) | | | | | | | | | | | | | | | |
|--------------------|--------------------|-----------------------|--|---|-------|---|-------|---|-------|---|-------|---|---|---|---|----|----|----|
| | | | 1 1/2 | 2 | 2 1/2 | 3 | 3 1/2 | 4 | 4 1/2 | 5 | 5 1/2 | 6 | 7 | 8 | 9 | 10 | 11 | 12 |
| 1/8 | .405 | 3/4 | 1 1/2 | 2 | 2 1/2 | 3 | 3 1/2 | 4 | 4 1/2 | 5 | 5 1/2 | 6 | 7 | 8 | 9 | 10 | 11 | 12 |
| 1/4 | .540 | 7/8 | 1 1/2 | 2 | 2 1/2 | 3 | 3 1/2 | 4 | 4 1/2 | 5 | 5 1/2 | 6 | 7 | 8 | 9 | 10 | 11 | 12 |
| 3/8 | .675 | 1 | 1 1/2 | 2 | 2 1/2 | 3 | 3 1/2 | 4 | 4 1/2 | 5 | 5 1/2 | 6 | 7 | 8 | 9 | 10 | 11 | 12 |
| 1/2 | .840 | 1 1/8 | 1 1/2 | 2 | 2 1/2 | 3 | 3 1/2 | 4 | 4 1/2 | 5 | 5 1/2 | 6 | 7 | 8 | 9 | 10 | 11 | 12 |
| 3/4 | 1.050 | 1 3/8 | 1 1/2 | 2 | 2 1/2 | 3 | 3 1/2 | 4 | 4 1/2 | 5 | 5 1/2 | 6 | 7 | 8 | 9 | 10 | 11 | 12 |
| 1 | 1.315 | 1 1/2 | | 2 | 2 1/2 | 3 | 3 1/2 | 4 | 4 1/2 | 5 | 5 1/2 | 6 | 7 | 8 | 9 | 10 | 11 | 12 |
| 1 1/4 | 1.660 | 1 5/8 | | 2 | 2 1/2 | 3 | 3 1/2 | 4 | 4 1/2 | 5 | 5 1/2 | 6 | 7 | 8 | 9 | 10 | 11 | 12 |
| 1 1/2 | 1.900 | 1 3/4 | | 2 | 2 1/2 | 3 | 3 1/2 | 4 | 4 1/2 | 5 | 5 1/2 | 6 | 7 | 8 | 9 | 10 | 11 | 12 |
| 2 | 2.375 | 2 | | | 2 1/2 | 3 | 3 1/2 | 4 | 4 1/2 | 5 | 5 1/2 | 6 | 7 | 8 | 9 | 10 | 11 | 12 |
| 2 1/2 | 2.875 | 2 1/2 | | | | 3 | 3 1/2 | 4 | 4 1/2 | 5 | 5 1/2 | 6 | 7 | 8 | 9 | 10 | 11 | 12 |
| 3 | 3.500 | 2 5/8 | | | | 3 | 3 1/2 | 4 | 4 1/2 | 5 | 5 1/2 | 6 | 7 | 8 | 9 | 10 | 11 | 12 |
| 4 | 4.500 | 2 7/8 | | | | | | 4 | 4 1/2 | 5 | 5 1/2 | 6 | 7 | 8 | 9 | 10 | 11 | 12 |
| 6 | 6.625 | 3 1/8 | | | | | | 4 | 4 1/2 | 5 | 5 1/2 | 6 | 7 | 8 | 9 | 10 | 11 | 12 |

SPF STEEL PIPE NIPPLES

Extra Heavy – SCH. 80 Welded

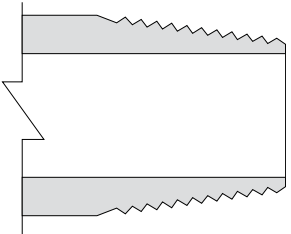
Anvil International is the only manufacturer where you can combine your import and U.S. Manufactured product requirements.

| STANDARDS & SPECIFICATIONS | |  <p>Standard End Finish Tapered Pipe Thread (NPT)</p> |  |
|---|---------------------------|--|---|
| Steel Pipe Nipples (Extra Heavy Welded) | | | |
| Dimensional: | ASTM A733 | | |
| Material: | ASTM A53 Type F or Type E | | |
| Galvanizing: | Hot Dip Galvanizing* | | |
| Threading: | ASME B 1.20.1 | | |



*Galvanized nipples are manufactured from pipe coated on the inside and outside by hot dip process.

- Ends are cut square to the central axis. All burrs on the inside are removed. The ends of the pipe nipples are chamfered on the outside at an angle of 35° +/- 10° to the central axis.
- Pipe nipples are threaded on both ends with standard NPT tapered threads. Threads are right hand on both ends.

| Pipe Size (in.) | Pipe O.D. (in.) | Length Close (in.) | Pipe Nipple Lengths (Black and galvanized) | | | | | | | | | | | | | | | |
|--------------------|--------------------|-----------------------|--|---|-------|---|-------|---|-------|---|-------|---|---|---|---|----|----|----|
| | | | 1 1/2 | 2 | 2 1/2 | 3 | 3 1/2 | 4 | 4 1/2 | 5 | 5 1/2 | 6 | 7 | 8 | 9 | 10 | 11 | 12 |
| 1/8 | .405 | 3/4 | 1 1/2 | 2 | 2 1/2 | 3 | 3 1/2 | 4 | 4 1/2 | 5 | 5 1/2 | 6 | 7 | 8 | 9 | 10 | 11 | 12 |
| 1/4 | .540 | 7/8 | 1 1/2 | 2 | 2 1/2 | 3 | 3 1/2 | 4 | 4 1/2 | 5 | 5 1/2 | 6 | 7 | 8 | 9 | 10 | 11 | 12 |
| 3/8 | .675 | 1 | 1 1/2 | 2 | 2 1/2 | 3 | 3 1/2 | 4 | 4 1/2 | 5 | 5 1/2 | 6 | 7 | 8 | 9 | 10 | 11 | 12 |
| 1/2 | .840 | 1 1/8 | 1 1/2 | 2 | 2 1/2 | 3 | 3 1/2 | 4 | 4 1/2 | 5 | 5 1/2 | 6 | 7 | 8 | 9 | 10 | 11 | 12 |
| 3/4 | 1.050 | 1 3/8 | 1 1/2 | 2 | 2 1/2 | 3 | 3 1/2 | 4 | 4 1/2 | 5 | 5 1/2 | 6 | 7 | 8 | 9 | 10 | 11 | 12 |
| 1 | 1.315 | 1 1/2 | | 2 | 2 1/2 | 3 | 3 1/2 | 4 | 4 1/2 | 5 | 5 1/2 | 6 | 7 | 8 | 9 | 10 | 11 | 12 |
| 1 1/4 | 1.660 | 1 5/8 | | 2 | 2 1/2 | 3 | 3 1/2 | 4 | 4 1/2 | 5 | 5 1/2 | 6 | 7 | 8 | 9 | 10 | 11 | 12 |
| 1 1/2 | 1.900 | 1 3/4 | | 2 | 2 1/2 | 3 | 3 1/2 | 4 | 4 1/2 | 5 | 5 1/2 | 6 | 7 | 8 | 9 | 10 | 11 | 12 |
| 2 | 2.375 | 2 | | | 2 1/2 | 3 | 3 1/2 | 4 | 4 1/2 | 5 | 5 1/2 | 6 | 7 | 8 | 9 | 10 | 11 | 12 |
| 2 1/2 | 2.875 | 2 1/2 | | | | 3 | 3 1/2 | 4 | 4 1/2 | 5 | 5 1/2 | 6 | 7 | 8 | 9 | 10 | 11 | 12 |
| 3 | 3.500 | 2 5/8 | | | | 3 | 3 1/2 | 4 | 4 1/2 | 5 | 5 1/2 | 6 | 7 | 8 | 9 | 10 | 11 | 12 |
| 3 1/2 | 4.000 | 2 3/4 | | | | | | 4 | 4 1/2 | 5 | 5 1/2 | 6 | 7 | 8 | 9 | 10 | 11 | 12 |
| 4 | 4.500 | 2 7/8 | | | | | | 4 | 4 1/2 | 5 | 5 1/2 | 6 | 7 | 8 | 9 | 10 | 11 | 12 |
| 5 | 5.563 | 3 | | | | | | 4 | 4 1/2 | 5 | 5 1/2 | 6 | 7 | 8 | 9 | 10 | 11 | 12 |
| 6 | 6.625 | 3 1/8 | | | | | | 4 | 4 1/2 | 5 | 5 1/2 | 6 | 7 | 8 | 9 | 10 | 11 | 12 |

Extra Heavy Seamless

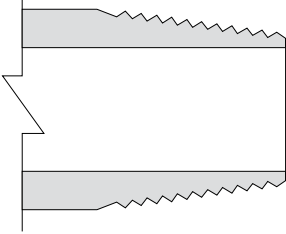
Anvil International is the only manufacturer where you can combine your import and U.S. Manufactured product requirements.

| STANDARDS & SPECIFICATIONS | | | |
|--|----------------------|--|---|
| Steel Pipe Nipples (Seamless Extra Heavy – Sch. 80)) | | | |
| Dimensional: | ASTM A733 | <p>Standard End Finish Tapered Pipe Thread (NPT)</p>  |  |
| Material: | ASTM A106 Grade B | | |
| Galvanizing: | Hot Dip Galvanizing* | | |
| Threading: | ASME B 1.20.1 | | |

*Galvanized nipples are manufactured from pipe coated on the inside and outside by hot dip process.

- Ends are cut square to the central axis. All burrs on the inside are removed. The ends of the pipe nipples are chamfered on the outside at an angle of 35° +/- 10° to the central axis.
- Pipe nipples are threaded on both ends with standard NPT tapered threads. Threads are right hand on both ends.

| Pipe Size (in.) | Pipe O.D. (in.) | Length Close (in.) | Pipe Nipple Lengths (Black and galvanized) | | | | | | | | | | | | | | | |
|--------------------|--------------------|-----------------------|--|---|-------|---|-------|---|-------|---|-------|---|---|---|---|----|----|----|
| | | | 1 1/2 | 2 | 2 1/2 | 3 | 3 1/2 | 4 | 4 1/2 | 5 | 5 1/2 | 6 | 7 | 8 | 9 | 10 | 11 | 12 |
| 1/8 | .405 | 3/4 | 1 1/2 | 2 | 2 1/2 | 3 | 3 1/2 | 4 | 4 1/2 | 5 | 5 1/2 | 6 | 7 | 8 | 9 | 10 | 11 | 12 |
| 1/4 | .540 | 7/8 | 1 1/2 | 2 | 2 1/2 | 3 | 3 1/2 | 4 | 4 1/2 | 5 | 5 1/2 | 6 | 7 | 8 | 9 | 10 | 11 | 12 |
| 3/8 | .675 | 1 | 1 1/2 | 2 | 2 1/2 | 3 | 3 1/2 | 4 | 4 1/2 | 5 | 5 1/2 | 6 | 7 | 8 | 9 | 10 | 11 | 12 |
| 1/2 | .840 | 1 1/8 | 1 1/2 | 2 | 2 1/2 | 3 | 3 1/2 | 4 | 4 1/2 | 5 | 5 1/2 | 6 | 7 | 8 | 9 | 10 | 11 | 12 |
| 3/4 | 1.050 | 1 3/8 | 1 1/2 | 2 | 2 1/2 | 3 | 3 1/2 | 4 | 4 1/2 | 5 | 5 1/2 | 6 | 7 | 8 | 9 | 10 | 11 | 12 |
| 1 | 1.315 | 1 1/2 | | 2 | 2 1/2 | 3 | 3 1/2 | 4 | 4 1/2 | 5 | 5 1/2 | 6 | 7 | 8 | 9 | 10 | 11 | 12 |
| 1 1/4 | 1.660 | 1 5/8 | | 2 | 2 1/2 | 3 | 3 1/2 | 4 | 4 1/2 | 5 | 5 1/2 | 6 | 7 | 8 | 9 | 10 | 11 | 12 |
| 1 1/2 | 1.900 | 1 3/4 | | 2 | 2 1/2 | 3 | 3 1/2 | 4 | 4 1/2 | 5 | 5 1/2 | 6 | 7 | 8 | 9 | 10 | 11 | 12 |
| 2 | 2.375 | 2 | | | 2 1/2 | 3 | 3 1/2 | 4 | 4 1/2 | 5 | 5 1/2 | 6 | 7 | 8 | 9 | 10 | 11 | 12 |
| 2 1/2 | 2.875 | 2 1/2 | | | | 3 | 3 1/2 | 4 | 4 1/2 | 5 | 5 1/2 | 6 | 7 | 8 | 9 | 10 | 11 | 12 |
| 3 | 3.500 | 2 5/8 | | | | 3 | 3 1/2 | 4 | 4 1/2 | 5 | 5 1/2 | 6 | 7 | 8 | 9 | 10 | 11 | 12 |
| 4 | 4.500 | 2 7/8 | | | | | | 4 | 4 1/2 | 5 | 5 1/2 | 6 | 7 | 8 | 9 | 10 | 11 | 12 |
| 5 | 5.563 | 3 | | | | | | | 4 1/2 | 5 | 5 1/2 | 6 | 7 | 8 | 9 | 10 | 11 | 12 |
| 6 | 6.625 | 3 1/8 | | | | | | | 4 1/2 | 5 | 5 1/2 | 6 | 7 | 8 | 9 | 10 | 11 | 12 |

SPF MALLEABLE IRON FITTINGS

Class 150 (Standard)

STANDARDS & SPECIFICATIONS

Import Malleable Iron Screwed Fittings (Class 150)

| | | | |
|-------------------|--|-----------------------|--|
| Dimensional: | Fittings: | ASME B16.3 |  |
| | Unions: | ASME B 16.39 | |
| | Bushings/Plugs: | ASME B 16.14 | |
| Material: | ASTM A-197 | | |
| Galvanizing: | ASTM A-153 | (Hot Dip Galvanizing) | |
| Threading:* | ASME B 1.20.1 | | |
| Pressure Rating: | Fittings: | ASME B 16.3 | |
| | Unions: | ASME B 16.39 | |
| | Bushings/Plugs: | ASME B 16.14 | |
| Pressure Testing: | All malleable iron fittings are tested for through wall porosity using an air under water process. | | |
| Agency Approvals: | All malleable iron fittings and unions are UL Listed and FM Approved. | | |

*British Standard threading per BS 21 available upon request.

| 90° REDUCING ELBOW | Size | A | B | Weight |
|---|---------------|------|------|--------|
| | in | in | in | lbs |
|  | 1/4 x 1/8 | 0.74 | 0.76 | 0.08 |
| | 3/8 x 1/8 | 0.81 | 0.85 | 0.11 |
| | 3/8 x 1/4 | 0.88 | 0.90 | 0.13 |
| | 1/2 x 1/4 | 0.97 | 0.98 | 0.16 |
| | 1/2 x 3/8 | 1.04 | 1.03 | 0.19 |
| | 3/4 x 3/8 | 1.12 | 1.13 | 0.26 |
| | 3/4 x 1/2 | 1.20 | 1.22 | 0.29 |
| | 1 x 1/2 | 1.26 | 1.36 | 0.42 |
| | 1 x 3/4 | 1.37 | 1.45 | 0.47 |
| | 1 1/4 x 1/2 | 1.34 | 1.53 | 0.54 |
| | 1 1/4 x 3/4 | 1.45 | 1.62 | 0.62 |
| | 1 1/4 x 1 | 1.58 | 1.67 | 0.73 |
| | 1 1/2 x 3/4 | 1.52 | 1.75 | 0.74 |
| | 1 1/2 x 1 | 1.65 | 1.80 | 0.88 |
| | 1 1/2 x 1 1/4 | 1.82 | 1.88 | 1.03 |
| | 2 x 3/4 | 1.60 | 1.97 | 1.04 |
| | 2 x 1 | 1.73 | 2.02 | 1.28 |
| | 2 x 1 1/4 | 1.90 | 2.10 | 1.36 |
| | 2 x 1 1/2 | 2.02 | 2.16 | 1.51 |
| | 2 1/2 x 1 1/2 | 2.16 | 2.51 | 2.20 |
| | 2 1/2 x 2 | 2.39 | 2.60 | 2.55 |
| | 3 x 2 | 2.52 | 2.89 | 3.35 |
| | 3 x 2 1/2 | 2.83 | 2.99 | 4.12 |
| | 4 x 3 | 3.30 | 3.60 | 6.65 |

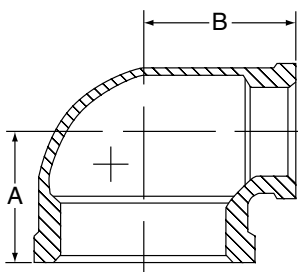

Class 150 (Standard)

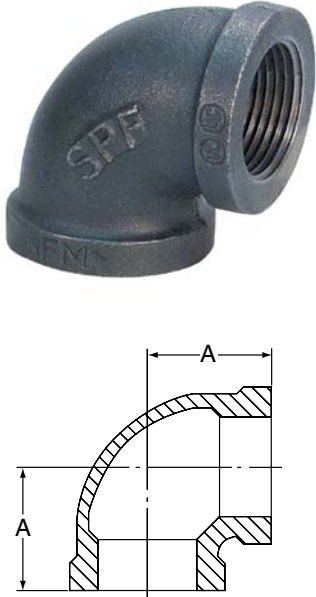
| 90° ELBOW | Size | A | Weight |
|--|-----------|-----------|------------|
| | <i>in</i> | <i>in</i> | <i>lbs</i> |
|  | 1/8 | 0.69 | 0.06 |
| | 1/4 | 0.81 | 0.10 |
| | 3/8 | 0.95 | 0.15 |
| | 1/2 | 1.12 | 0.22 |
| | 3/4 | 1.31 | 0.36 |
| | 1 | 1.50 | 0.57 |
| | 1 1/4 | 1.75 | 0.87 |
| | 1 1/2 | 1.94 | 1.16 |
| | 2 | 2.25 | 1.81 |
| | 2 1/2 | 2.70 | 3.23 |
| | 3 | 3.08 | 4.82 |
| | 4 | 3.79 | 8.41 |
| | 6 | 5.13 | 19.96 |

| 45° ELBOW | Size | A | Weight |
|---|-----------|-----------|------------|
| | <i>in</i> | <i>in</i> | <i>lbs</i> |
|  | 1/8 | 0.63 | 0.06 |
| | 1/4 | 0.73 | 0.11 |
| | 3/8 | 0.80 | 0.14 |
| | 1/2 | 0.88 | 0.20 |
| | 3/4 | 0.98 | 0.32 |
| | 1 | 1.12 | 0.50 |
| | 1 1/4 | 1.29 | 0.76 |
| | 1 1/2 | 1.43 | 1.00 |
| | 2 | 1.68 | 1.61 |
| | 2 1/2 | 1.95 | 2.77 |
| | 3 | 2.17 | 4.03 |
| | 4 | 2.61 | 6.92 |
| | 6 | 3.46 | 16.31 |

SPF MALLEABLE IRON FITTINGS

Class 150 (Standard)

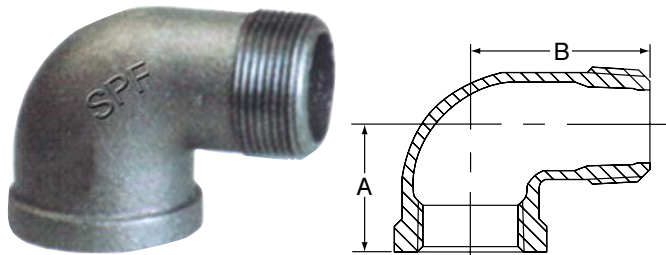
| 90° STREET ELBOW | | Size | A | B | Weight |
|---|-------|-------------|-----------|-----------|---------------|
| | | <i>in</i> | <i>in</i> | <i>in</i> | <i>lbs</i> |
|  | 1/8 | 0.69 | 1.00 | 0.05 | |
| | 1/4 | 0.81 | 1.19 | 0.09 | |
| | 3/8 | 0.95 | 1.44 | 0.15 | |
| | 1/2 | 1.12 | 1.63 | 0.20 | |
| | 3/4 | 1.31 | 1.89 | 0.34 | |
| | 1 | 1.50 | 2.14 | 0.58 | |
| | 1 1/4 | 1.75 | 2.45 | 0.84 | |
| | 1 1/2 | 1.94 | 2.69 | 1.12 | |
| | 2 | 2.25 | 3.26 | 1.85 | |
| | 2 1/2 | 2.70 | 3.86 | 3.28 | |
| | 3 | 3.08 | 4.51 | 5.00 | |
| | 4 | 3.79 | 5.69 | 9.18 | |

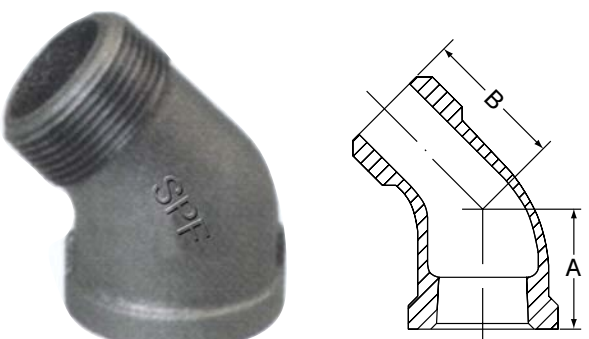
| 45° STREET ELBOW | | Size | A | B | Weight |
|---|-------|-------------|-----------|-----------|---------------|
| | | <i>in</i> | <i>in</i> | <i>in</i> | <i>lbs</i> |
|  | 1/8 | 0.63 | 0.83 | 0.05 | |
| | 1/4 | 0.73 | 0.94 | 0.08 | |
| | 3/8 | 0.80 | 1.03 | 0.12 | |
| | 1/2 | 0.88 | 1.15 | 0.18 | |
| | 3/4 | 0.98 | 1.29 | 0.27 | |
| | 1 | 1.12 | 1.47 | 0.44 | |
| | 1 1/4 | 1.29 | 1.71 | 0.70 | |
| | 1 1/2 | 1.43 | 1.88 | 0.92 | |
| | 2 | 1.68 | 2.22 | 1.50 | |

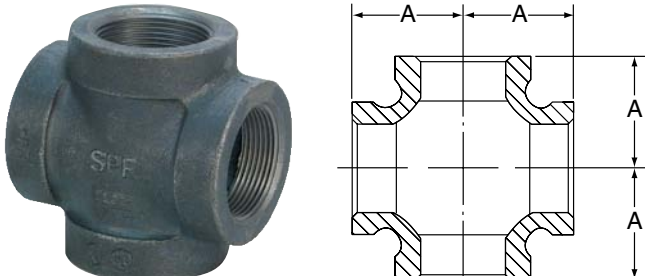
| CROSS | | Size | A | Weight |
|---|-------|-------------|-----------|---------------|
| | | <i>in</i> | <i>in</i> | <i>lbs</i> |
|  | 1/4 | 0.81 | 0.17 | |
| | 3/8 | 0.95 | 0.26 | |
| | 1/2 | 1.12 | 0.38 | |
| | 3/4 | 1.31 | 0.61 | |
| | 1 | 1.50 | 0.95 | |
| | 1 1/4 | 1.75 | 1.42 | |
| | 1 1/2 | 1.94 | 1.86 | |
| | 2 | 2.25 | 2.83 | |

Class 150 (Standard)

| CAP | Size | A | Weight |
|---|-----------|-----------|------------|
| | <i>in</i> | <i>in</i> | <i>lbs</i> |
|  | 1/8 ▲ | 0.53 | 0.03 |
| | 1/4 ▲ | 0.63 | 0.05 |
| | 3/8 ▲ | 0.74 | 0.07 |
| | 1/2 | 0.87 | 0.11 |
| | 3/4 | 0.97 | 0.18 |
| | 1 | 1.16 | 0.30 |
| | 1 1/4 | 1.28 | 0.44 |
| | 1 1/2 | 1.33 | 0.55 |
| | 2 | 1.45 | 0.85 |
| | 2 1/2 | 1.70 | 1.49 |
| | 3 | 1.80 | 2.20 |
| | 3 1/2 | 1.90 | 3.02 |
| | 4 | 2.08 | 3.79 |
| 6 | 2.55 | 8.77 | |

▲ Supplied in Steel only (Black and Galvanized).

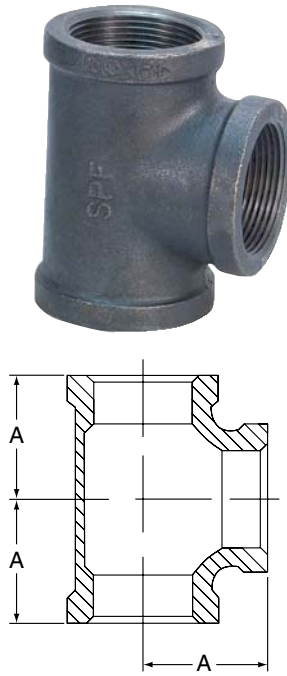
| TEE | Size | A | Weight |
|---|-----------|-----------|------------|
| | <i>in</i> | <i>in</i> | <i>lbs</i> |
|  | 1/8 | 0.69 | 0.09 |
| | 1/4 | 0.81 | 0.14 |
| | 3/8 | 0.95 | 0.21 |
| | 1/2 | 1.12 | 0.31 |
| | 3/4 | 1.31 | 0.50 |
| | 1 | 1.50 | 0.79 |
| | 1 1/4 | 1.75 | 1.19 |
| | 1 1/2 | 1.94 | 1.57 |
| | 2 | 2.25 | 2.43 |
| | 2 1/2 | 2.70 | 4.33 |
| | 3 | 3.08 | 6.37 |
| | 4 | 3.79 | 11.03 |

SPF MALLEABLE IRON FITTINGS

Class 150 (Standard)

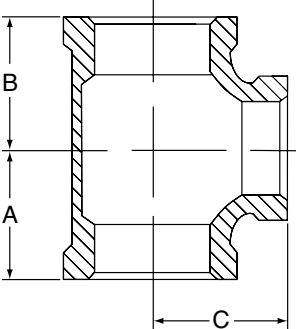
| REDUCING TEE | Size | | | A | B | C | Weight | |
|---|-------|-------|-------|-------|------|------|--------|------|
| | in | | | in | in | in | lbs | |
|   | 1/2 | 1/2 | 1/4 | 0.97 | 0.97 | 0.98 | 0.24 | |
| | | | 3/8 | 1.04 | 1.04 | 1.03 | 0.27 | |
| | | | 3/4 | 1.22 | 1.22 | 1.20 | 0.37 | |
| | | | 1 | 1.36 | 1.36 | 1.26 | 0.49 | |
| | 3/4 | 1/2 | 1/2 | 1.20 | 1.12 | 1.22 | 0.38 | |
| | | | 3/4 | 1.31 | 1.22 | 1.31 | 0.45 | |
| | | 3/4 | 1/4 | 1.05 | 1.05 | 1.08 | 0.36 | |
| | | | 3/8 | 1.12 | 1.12 | 1.13 | 0.39 | |
| | | | 1/2 | 1.20 | 1.20 | 1.22 | 0.43 | |
| | | | 1 | 1.45 | 1.45 | 1.37 | 0.62 | |
| | 1 | 1/4 | 1/4 | 1 | 1.50 | 1.18 | 1.50 | 0.63 |
| | | | 1/2 | 1.26 | 1.12 | 1.36 | 0.48 | |
| | | 1/2 | 3/4 | 1.37 | 1.22 | 1.45 | 0.56 | |
| | | | 1 | 1.50 | 1.36 | 1.50 | 0.67 | |
| | | | 1 1/4 | 1.67 | 1.67 | 1.58 | 0.94 | |
| | | 3/4 | 1/2 | 1.26 | 1.20 | 1.36 | 0.53 | |
| | | | 3/4 | 1.37 | 1.31 | 1.45 | 0.61 | |
| | | | 1 | 1.50 | 1.45 | 1.50 | 0.71 | |
| | | | 1 1/4 | 1.67 | 1.67 | 1.58 | 0.94 | |
| | | 1 | 1 | 3/8 | 1.18 | 1.18 | 1.27 | 0.57 |
| | | | | 1/2 | 1.26 | 1.26 | 1.36 | 0.62 |
| | | | | 3/4 | 1.37 | 1.37 | 1.45 | 0.69 |
| | | | 1 1/4 | 1 1/2 | 1.80 | 1.80 | 1.65 | 1.07 |
| | | | | 2 | 2.02 | 2.02 | 1.73 | 1.45 |
| | 2 1/2 | | | 2.24 | 2.24 | 1.81 | 1.83 | |
| | 1 1/4 | 1/2 | 1 | 1.58 | 1.36 | 1.67 | 0.82 | |
| | | | 1 1/4 | 1.75 | 1.53 | 1.75 | 0.95 | |
| | | 3/4 | 3/4 | 1.45 | 1.31 | 1.62 | 0.75 | |
| | | | 1 | 1.58 | 1.45 | 1.67 | 0.87 | |
| | | | 1 1/4 | 1.75 | 1.62 | 1.75 | 1.00 | |
| | | 1 | 1/2 | 1.34 | 1.26 | 1.53 | 0.74 | |
| | | | 3/4 | 1.45 | 1.37 | 1.62 | 0.82 | |
| 1 | | | 1.58 | 1.50 | 1.67 | 0.94 | | |
| 1 1/4 | | | 1.75 | 1.67 | 1.75 | 1.08 | | |
| 1 1/4 | | 1 1/4 | 1/2 | 1.34 | 1.34 | 1.53 | 0.84 | |
| | | | 3/4 | 1.45 | 1.45 | 1.62 | 0.92 | |
| | | 1 | 1.58 | 1.58 | 1.67 | 1.04 | | |
| | 1 1/2 | 1.88 | 1.88 | 1.82 | 1.34 | | | |
| | 2 | 2.10 | 2.10 | 1.90 | 1.65 | | | |

**CONTINUED
ON NEXT PAGE.**

SPF MALLEABLE IRON FITTINGS

Class 150 (Standard)

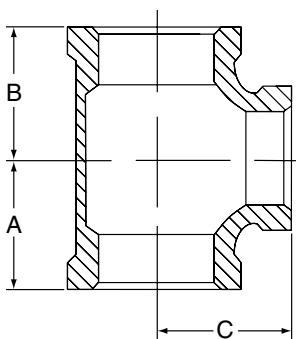
| REDUCING TEE | Size | | A | B | C | Weight | |
|---|-------|-------|-------|------|------|--------|------|
| | in | | in | in | in | lbs | |
|   | 1 1/2 | 1/2 | 1 1/2 | 1.94 | 1.66 | 1.94 | 1.24 |
| | | 3/4 | 3/4 | 1.50 | 1.26 | 1.69 | 0.86 |
| | | | 1 1/2 | 1.94 | 1.75 | 1.94 | 1.29 |
| | | 1 | 1 | 1.65 | 1.50 | 1.80 | 1.08 |
| | | | 1 1/4 | 1.82 | 1.67 | 1.88 | 1.23 |
| | | | 1 1/2 | 1.94 | 1.80 | 1.94 | 1.35 |
| | | 1 1/4 | 3/4 | 1.52 | 1.45 | 1.75 | 1.04 |
| | | | 1 | 1.65 | 1.58 | 1.80 | 1.17 |
| | | | 1 1/4 | 1.82 | 1.75 | 1.88 | 1.32 |
| | | | 1 1/2 | 1.94 | 1.88 | 1.94 | 1.45 |
| | | 1 1/2 | 1/2 | 1.41 | 1.41 | 1.66 | 1.04 |
| | | | 3/4 | 1.52 | 1.52 | 1.75 | 1.14 |
| | 1 | | 1.65 | 1.65 | 1.80 | 1.27 | |
| | 1 1/4 | | 1.82 | 1.82 | 1.88 | 1.43 | |
| | 2 | | 2.16 | 2.16 | 2.02 | 1.89 | |
| | 2 | 1/2 | 2 | 2.25 | 1.88 | 2.25 | 1.89 |
| | | 3/4 | 2 | 2.25 | 1.97 | 2.25 | 1.93 |
| | | 1 | 2 | 2.25 | 2.02 | 2.25 | 2.00 |
| | | 1 1/4 | 1 1/4 | 1.90 | 1.75 | 2.10 | 1.64 |
| | | | 1 1/2 | 2.02 | 1.88 | 2.16 | 1.80 |
| | | 1 1/2 | 2 | 2.25 | 2.10 | 2.25 | 2.09 |
| | | | 1 | 1.73 | 1.65 | 2.02 | 1.57 |
| | | | 1 1/4 | 1.90 | 1.82 | 2.10 | 1.71 |
| | | | 1 1/2 | 2.02 | 1.94 | 2.16 | 1.88 |
| | | 2 | 2 | 2.25 | 2.16 | 2.25 | 2.21 |
| | | | 1/2 | 1.49 | 1.49 | 1.88 | 1.53 |
| | | | 3/4 | 1.60 | 1.60 | 1.97 | 1.63 |
| | 1 | | 1.73 | 1.73 | 2.02 | 1.78 | |
| | 1 1/4 | | 1.90 | 1.90 | 2.10 | 1.97 | |
| | 2 1/2 | 1 1/2 | 2.02 | 2.02 | 2.16 | 2.12 | |
| | | 2 1/2 | 2.60 | 2.60 | 2.39 | 3.15 | |
| | | 3/4 | 1.74 | 1.74 | 2.32 | 2.67 | |
| | | 1 | 1.87 | 1.87 | 2.37 | 2.84 | |
| | | 1 1/4 | 2.04 | 2.04 | 2.45 | 3.09 | |
| | 3 | 1 1/2 | 2.16 | 2.16 | 2.51 | 3.29 | |
| | | 2 | 2.39 | 2.39 | 2.60 | 3.65 | |
| | | 1 | 2.00 | 2.00 | 2.66 | 3.96 | |
| | | 1 1/4 | 2.17 | 2.17 | 2.74 | 4.23 | |
| | | 1 1/2 | 2.29 | 2.29 | 2.80 | 4.45 | |
| | 4 | 2 | 2.52 | 2.52 | 2.89 | 4.90 | |
| 2 1/2 | | 2.83 | 2.83 | 2.99 | 5.69 | | |
| 2 | | 2.74 | 2.74 | 3.41 | 7.52 | | |
| 4 | 2 1/2 | 3.05 | 3.05 | 3.51 | 8.51 | | |
| | 3 | 3.30 | 3.30 | 3.60 | 9.25 | | |

SPF MALLEABLE IRON FITTINGS

Class 150 (Standard)

| FLOOR FLANGE | Size | Dia. Flange | Dia. of Bolt Circle | Dia. of Bolt Holes | Weight |
|---|-----------|-------------|---------------------|--------------------|------------|
| | <i>in</i> | <i>in</i> | <i>in</i> | <i>in</i> | <i>lbs</i> |
|  | ¾ | 3.37 | 2.36 | .28 | 0.49 |
| | 1 | 3.78 | 2.80 | .28 | 0.63 |
| | 1 ¼ | 4.19 | 3.17 | .28 | 0.87 |
| | 1 ½ | 4.59 | 3.50 | .31 | 1.10 |
| | 2 | 5.18 | 4.01 | .31 | 1.57 |

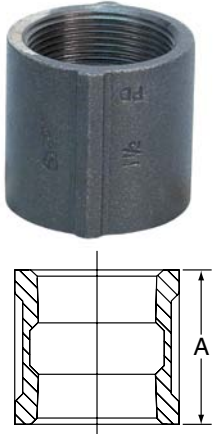
| COUPLING | Size | A | Weight |
|--|-----------|-----------|------------|
| | <i>in</i> | <i>in</i> | <i>lbs</i> |
|  | ⅛ | 0.96 | 0.05 |
| | ¼ | 1.06 | 0.08 |
| | ⅜ | 1.16 | 0.12 |
| | ½ | 1.34 | 0.17 |
| | ¾ | 1.52 | 0.27 |
| | 1 | 1.67 | 0.43 |
| | 1 ¼ | 1.93 | 0.65 |
| | 1 ½ | 2.15 | 0.86 |
| | 2 | 2.53 | 1.35 |
| | 2 ½ | 2.88 | 2.33 |
| | 3 | 3.18 | 3.36 |
| | 4 | 3.69 | 5.59 |

| UNIONS (BRASS SEAT) | Size | A (<i>in</i>) | | Weight (<i>lbs</i>) | |
|---|------|-----------------|------|-----------------------|------|
| | | SPF/Anvil | Tupy | SPF/Anvil | Tupy |
|  | ⅛ | 1.26 | – | 0.16 | – |
| | ¼ | 1.46 | 1.65 | 0.23 | 0.23 |
| | ⅜ | 1.61 | 1.77 | 0.33 | 0.29 |
| | ½ | 1.73 | 1.89 | 0.41 | 0.43 |
| | ¾ | 1.95 | 2.05 | 0.60 | 0.64 |
| | 1 | 2.07 | 2.28 | 0.89 | 0.80 |
| | 1 ¼ | 2.26 | 2.56 | 1.25 | 1.40 |
| | 1 ½ | 2.42 | 2.76 | 1.76 | 1.69 |
| | 2 | 2.75 | 3.07 | 2.44 | 2.66 |
| | 2 ½ | 3.23 | 3.35 | 3.52 | 3.87 |
| | 3 | 3.50 | 3.74 | 4.34 | 5.81 |

Class 150 (Standard)

| REDUCING COUPLINGS | Size | A | Weight |
|---|---------------|-----------|------------|
| | <i>in</i> | <i>in</i> | <i>lbs</i> |
|  | 1/4 x 1/8 | 1.00 | 0.07 |
| | 3/8 x 1/8 | 1.13 | 0.09 |
| | 3/8 x 1/4 | 1.13 | 0.10 |
| | 1/2 x 1/8 | 1.25 | 0.13 |
| | 1/2 x 1/4 | 1.25 | 0.13 |
| | 1/2 x 3/8 | 1.25 | 0.14 |
| | 3/4 x 1/8 | 1.44 | 0.18 |
| | 3/4 x 1/4 | 1.44 | 0.20 |
| | 3/4 x 3/8 | 1.44 | 0.21 |
| | 3/4 x 1/2 | 1.44 | 0.22 |
| | 1 x 1/2 | 1.69 | 0.34 |
| | 1 x 3/4 | 1.69 | 0.36 |
| | 1 1/4 x 1/2 | 2.06 | 0.47 |
| | 1 1/4 x 3/4 | 2.06 | 0.51 |
| | 1 1/4 x 1 | 2.06 | 0.57 |
| | 1 1/2 x 1/2 | 2.31 | 0.62 |
| | 1 1/2 x 3/4 | 2.31 | 0.66 |
| | 1 1/2 x 1 | 2.31 | 0.73 |
| | 1 1/2 x 1 1/4 | 2.31 | 0.80 |
| | 2 x 1/2 | 2.81 | 0.94 |
| | 2 x 3/4 | 2.81 | 0.99 |
| | 2 x 1 | 2.81 | 1.03 |
| | 2 x 1 1/4 | 2.81 | 1.17 |
| | 2 x 1 1/2 | 2.81 | 1.25 |
| | 2 1/2 x 1 1/4 | 3.25 | 1.81 |
| | 2 1/2 x 1 1/2 | 3.25 | 1.90 |
| | 2 1/2 x 2 | 3.25 | 2.04 |
| | 3 x 1 | 3.69 | 2.48 |
| | 3 x 1 1/4 | 3.69 | 2.55 |
| | 3 x 1 1/2 | 3.69 | 2.67 |
| 3 x 2 | 3.69 | 2.78 | |
| 3 x 2 1/2 | 3.69 | 3.23 | |
| 4 x 2 | 4.38 | 4.43 | |
| 4 x 2 1/2 | 4.38 | 4.87 | |
| 4 x 3 | 4.38 | 5.29 | |

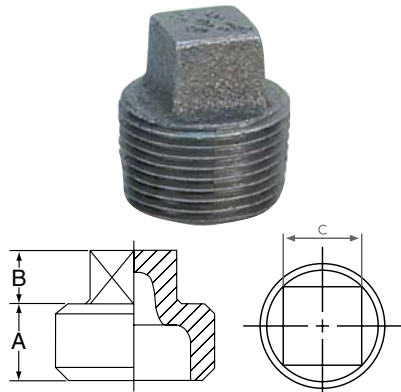
| PLUGS | | Size | A | B | C | Weight |
|---|----------|-----------|-----------|-----------|-----------|------------|
| | | <i>in</i> | <i>in</i> | <i>in</i> | <i>in</i> | <i>lbs</i> |
|  | Solid | 1/4 | 0.44 | 0.28 | 0.38 | 0.04 |
| | Solid | 3/8 | 0.48 | 0.31 | 0.44 | 0.06 |
| | Cored | 1/2 | 0.56 | 0.38 | 0.56 | 0.08 |
| | Cored | 3/4 | 0.63 | 0.44 | 0.63 | 0.13 |
| | Cored | 1 | 0.75 | 0.50 | 0.81 | 0.20 |
| | Cored | 1 1/4 | 0.80 | 0.56 | 0.94 | 0.32 |
| | Cored | 1 1/2 | 0.83 | 0.62 | 1.13 | 0.43 |
| | Cored | 2 | 0.88 | 0.68 | 1.31 | 0.67 |
| | Cored | 2 1/2 | 1.07 | 0.74 | 1.50 | 1.11 |
| | Cored | 3 | 1.13 | 0.80 | 1.69 | 1.53 |
| | Bar Plug | 4 | 1.22 | 1.00 | – | 2.71 |
| | Bar Plug | 6 | 1.40 | 1.25 | – | 4.00 |

SPF MALLEABLE IRON FITTINGS

Class 150 (Standard)

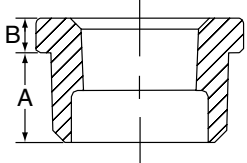
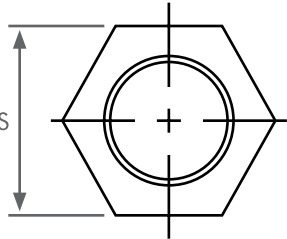
| HEX BUSHING | Size | A | B | S | Weight | Hex |
|---|---------------|------|------|------|---------|---------|
| | in | in | in | in | lbs | |
|    | 3/4 x 1/2 | 0.63 | 0.22 | 1.15 | 0.11 | outside |
| | 1 x 1/8 | 0.75 | 0.30 | 1.12 | 0.18 | inside |
| | 1 x 1/4 | 0.75 | 0.30 | 1.12 | 0.21 | inside |
| | 1 x 3/8 | 0.75 | 0.30 | 1.12 | 0.20 | inside |
| | 1 x 1/2 | 0.75 | 0.25 | 1.42 | 0.22 | outside |
| | 1 x 3/4 | 0.75 | 0.25 | 1.42 | 0.18 | outside |
| | 1 1/4 x 1/2 | 0.80 | 0.34 | 1.34 | 0.32 | inside |
| | 1 1/4 x 3/4 | 0.80 | 0.28 | 1.76 | 0.37 | outside |
| | 1 1/4 x 1 | 0.80 | 0.28 | 1.76 | 0.30 | outside |
| | 1 1/2 x 1/4 | 0.83 | 0.37 | 1.12 | 0.38 | inside |
| | 1 1/2 x 3/8 | 0.83 | 0.37 | 1.12 | 0.38 | inside |
| | 1 1/2 x 1/2 | 0.83 | 0.37 | 1.34 | 0.40 | inside |
| | 1 1/2 x 3/4 | 0.83 | 0.37 | 1.63 | 0.45 | inside |
| | 1 1/2 x 1 | 0.83 | 0.31 | 2.00 | 0.46 | outside |
| | 1 1/2 x 1 1/4 | 0.83 | 0.31 | 2.00 | 0.31 | outside |
| | 2 x 1/2 | 0.88 | 0.41 | 1.34 | 0.56 | inside |
| | 2 x 3/4 | 0.88 | 0.41 | 1.63 | 0.61 | inside |
| | 2 x 1 | 0.88 | 0.41 | 1.95 | 0.65 | inside |
| | 2 x 1 1/4 | 0.88 | 0.34 | 2.48 | 0.80 | outside |
| | 2 x 1 1/2 | 0.88 | 0.34 | 2.48 | 0.66 | outside |
| | 2 1/2 x 3/4 | 1.07 | 0.44 | 1.63 | 0.98 | inside |
| | 2 1/2 x 1 | 1.07 | 0.44 | 1.95 | 1.04 | inside |
| | 2 1/2 x 1 1/4 | 1.07 | 0.44 | 2.39 | 1.10 | inside |
| | 2 1/2 x 1 1/2 | 1.07 | 0.44 | 2.68 | 1.38 | outside |
| | 2 1/2 x 2 | 1.07 | 0.37 | 2.98 | 0.97 | outside |
| | 3 x 1 | 1.13 | 0.48 | 1.95 | 1.48 | inside |
| | 3 x 1 1/4 | 1.13 | 0.48 | 2.39 | 1.57 | inside |
| | 3 x 1 1/2 | 1.13 | 0.48 | 2.68 | 1.62 | inside |
| | 3 x 2 | 1.13 | 0.48 | 3.28 | 2.10 | outside |
| | 3 x 2 1/2 | 1.13 | 0.40 | 3.86 | 1.84 | outside |
| | 3 1/2 x 3 | 1.18 | 0.43 | 4.62 | 2.10 | outside |
| | 4 x 1 | 1.22 | 0.60 | 1.95 | 2.60 | inside |
| 4 x 1 1/4 | 1.22 | 0.60 | 2.39 | 2.74 | inside | |
| 4 x 1 1/2 | 1.22 | 0.60 | 2.68 | 2.81 | inside | |
| 4 x 2 | 1.22 | 0.60 | 3.28 | 2.91 | inside | |
| 4 x 2 1/2 | 1.22 | 0.60 | 3.86 | 2.98 | inside | |
| 4 x 3 | 1.22 | 0.50 | 4.62 | 2.93 | outside | |

SPF MALLEABLE IRON FITTINGS

Class 300 (Extra Heavy)

STANDARDS & SPECIFICATIONS

Malleable Iron Screwed Fittings (Class 300)

| | | | |
|-------------------|--|-----------------------|--|
| Dimensional: | Fittings: | ASME B16.3 |  |
| | Unions: | ASME B 16.39 | |
| | Bushings/Plugs: | ASME B 16.14 | |
| Material: | ASTM A-197 | | |
| Galvanizing: | ASTM A-153 | (Hot Dip Galvanizing) | |
| Threading: | ASME B 1.20.1 | | |
| Pressure Rating: | Fittings: | ASME B 16.3 | |
| | Unions: | ASME B 16.39 | |
| | Bushings/Plugs: | ASME B 16.14 | |
| Pressure Testing: | All malleable iron fittings are tested for through wall porosity using an air under water process. | | |
| Agency Approvals: | All malleable iron fittings and unions are UL Listed and FM Approved. | | |

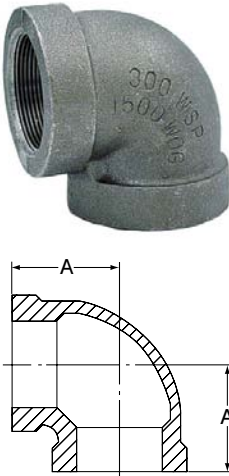
| 90° ELBOW  | Size | A | Weight |
|---|-----------|-----------|------------|
| | <i>in</i> | <i>in</i> | <i>lbs</i> |
| | 1/4 | 0.94 | 0.20 |
| | 3/8 | 1.06 | 0.29 |
| | 1/2 | 1.25 | 0.47 |
| | 3/4 | 1.44 | 0.66 |
| | 1 | 1.63 | 1.20 |
| | 1 1/4 | 1.94 | 1.90 |
| | 1 1/2 | 2.13 | 2.50 |
| | 2 | 2.50 | 4.20 |
| | 2 1/2 | 2.94 | 5.30 |
| | 3 | 3.38 | 9.70 |
| | 4 | 4.50 | 16.00 |

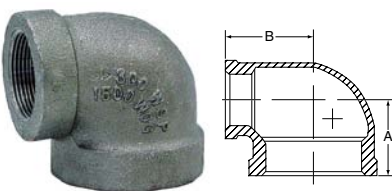
| 90° REDUCING ELBOW  | Size | A | B | Weight |
|--|-----------|-----------|-----------|------------|
| | <i>in</i> | <i>in</i> | <i>in</i> | <i>lbs</i> |
| | 1/2 x 3/8 | 1.19 | 1.19 | 0.41 |
| | 1 x 3/4 | 1.50 | 1.56 | 1.00 |

SPF MALLEABLE IRON FITTINGS

Class 300 (Extra Heavy)

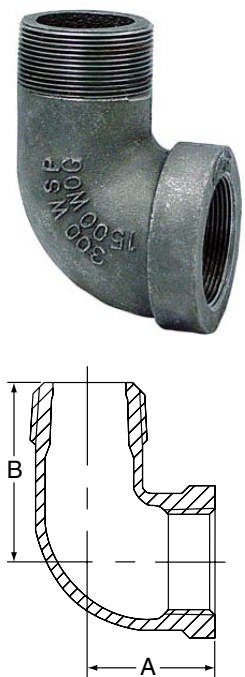
| 90° STREET ELBOW | Size | A | B | Weight |
|--|-----------|-----------|-----------|------------|
| | <i>in</i> | <i>in</i> | <i>in</i> | <i>lbs</i> |
|  | 1/4 | 0.94 | 1.44 | 0.17 |
| | 3/8 | 1.06 | 1.63 | 0.26 |
| | 1/2 | 1.25 | 2.00 | 0.40 |
| | 3/4 | 1.44 | 2.19 | 0.68 |
| | 1 | 1.63 | 2.56 | 1.10 |
| | 1 1/4 | 1.94 | 2.88 | 1.60 |
| | 1 1/2 | 2.13 | 3.13 | 2.20 |
| | 2 | 2.50 | 3.69 | 3.60 |
| | 3 | 3.38 | 5.13 | 9.60 |

| 45° ELBOW | Size | A | Weight |
|---|-----------|-----------|------------|
| | <i>in</i> | <i>in</i> | <i>lbs</i> |
|  | 1/4 | 0.81 | 0.19 |
| | 3/8 | 0.88 | 1.28 |
| | 1/2 | 1.00 | 0.43 |
| | 3/4 | 1.13 | 0.66 |
| | 1 | 1.31 | 1.00 |
| | 1 1/4 | 1.50 | 1.70 |
| | 1 1/2 | 1.69 | 2.10 |
| | 2 | 2.00 | 3.40 |
| | 2 1/2 | 2.25 | 5.50 |
| | 3 | 2.50 | 8.10 |
| 4 | 2.81 | 13.00 | |

Class 300 (Extra Heavy)

| CAP | Size | A | Weight |
|---|-----------|-----------|------------|
| | <i>in</i> | <i>in</i> | <i>lbs</i> |
|  | 1/4 | 0.78 | 0.10 |
| | 3/8 | 0.81 | 0.15 |
| | 1/2 | 1.00 | 2.23 |
| | 3/4 | 1.06 | 0.35 |
| | 1 | 1.25 | 0.58 |
| | 1 1/4 | 1.38 | 0.94 |
| | 1 1/2 | 1.44 | 1.20 |
| | 2 | 1.69 | 1.90 |
| | 2 1/2 | 2.06 | 3.30 |
| | 3 | 2.19 | 4.70 |

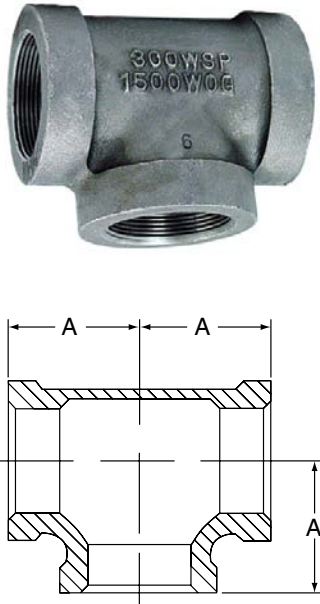
| TEE | Size | A | Weight |
|---|-----------|-----------|------------|
| | <i>in</i> | <i>in</i> | <i>lbs</i> |
|  | 1/4 | 1.31 | 0.27 |
| | 3/8 | 1.06 | 0.42 |
| | 1/2 | 1.25 | 0.65 |
| | 3/4 | 1.44 | 1.10 |
| | 1 | 1.63 | 1.60 |
| | 1 1/4 | 1.94 | 2.50 |
| | 1 1/2 | 2.13 | 3.40 |
| | 2 | 2.50 | 5.20 |
| | 2 1/2 | 2.94 | 8.00 |
| | 3 | 3.38 | 13.00 |
| | 4 | 4.50 | 24.00 |

SPF MALLEABLE IRON FITTINGS

Class 300 (Extra Heavy)

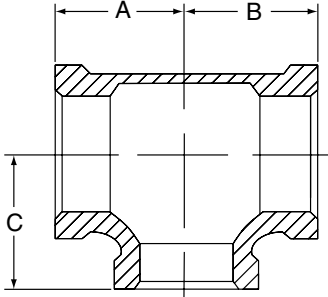
| REDUCING TEE | Size | | | A | B | C | Weight |
|---|-------|-------|-------|------|------|------|--------|
| | in | | | in | in | in | lbs |
|   | 3/4 | 3/4 | 1/2 | 1.31 | 1.31 | 1.38 | 0.90 |
| | 1 | 1 | 1/2 | 1.44 | 1.44 | 1.50 | 1.30 |
| | | | 3/4 | 1.50 | 1.50 | 1.56 | 1.30 |
| | 1 1/4 | 1 1/4 | 1/2 | 1.50 | 1.50 | 1.69 | 1.70 |
| | | | 3/4 | 1.63 | 1.63 | 1.75 | 1.90 |
| | | | 1 | 1.75 | 1.75 | 1.81 | 2.10 |
| | 1 1/2 | 1 1/2 | 1/2 | 1.63 | 1.63 | 1.81 | 2.30 |
| | | | 3/4 | 1.69 | 1.69 | 1.88 | 2.50 |
| | | | 1 | 1.81 | 1.81 | 2.00 | 2.60 |
| | | | 1 1/4 | 2.00 | 2.00 | 2.06 | 3.00 |
| | 2 | 2 | 1/2 | 1.75 | 1.75 | 2.06 | 3.40 |
| | | | 3/4 | 1.81 | 1.81 | 2.13 | 3.60 |
| | | | 1 | 2.00 | 2.00 | 2.25 | 4.00 |
| | | | 1 1/4 | 2.13 | 2.13 | 2.31 | 4.20 |
| | | | 1 1/2 | 2.25 | 2.25 | 2.38 | 4.60 |
| 2 1/2 | 2 1/2 | 2 | 2.69 | 2.69 | 2.75 | 7.60 | |
| 3 | 3 | 2 | 2.81 | 2.81 | 3.13 | 9.60 | |

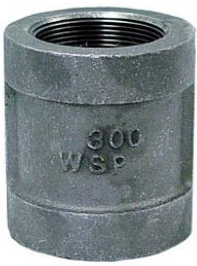
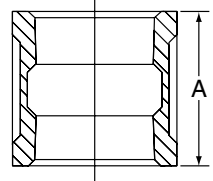
| COUPLING | Size | A | Weight |
|--|-------|------|--------|
| | in | in | lbs |
|   | 1/4 | 1.38 | 0.17 |
| | 3/8 | 1.63 | 0.26 |
| | 1/2 | 1.88 | 0.42 |
| | 3/4 | 2.13 | 0.65 |
| | 1 | 2.38 | 0.99 |
| | 1 1/4 | 2.88 | 1.60 |
| | 1 1/2 | 2.88 | 2.00 |
| | 2 | 3.63 | 3.20 |
| | 2 1/2 | 4.13 | 5.50 |
| | 3 | 4.13 | 7.30 |

Class 300 (Extra Heavy)

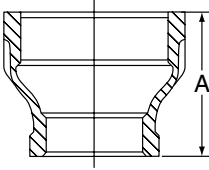
| REDUCING COUPLINGS | Size | A | Weight |
|--|---------------|-----------|------------|
| | <i>in</i> | <i>in</i> | <i>lbs</i> |
|   | 3/8 x 1/4 | 1.44 | 0.21 |
| | 1/2 x 1/4 | 1.69 | 0.31 |
| | 1/2 x 3/8 | 1.69 | 0.34 |
| | 3/4 x 3/8 | 1.75 | 0.47 |
| | 3/4 x 1/2 | 1.75 | 0.50 |
| | 1 x 1/2 | 2.00 | 0.71 |
| | 1 x 3/4 | 2.00 | 0.79 |
| | 1 1/4 x 1/2 | 2.38 | 1.10 |
| | 1 1/4 x 3/4 | 2.38 | 1.20 |
| | 1 1/4 x 1 | 2.38 | 1.30 |
| | 1 1/2 x 1/2 | 2.69 | 1.50 |
| | 1 1/2 x 3/4 | 2.69 | 1.60 |
| | 1 1/2 x 1 | 2.69 | 1.60 |
| | 1 1/2 x 1 1/4 | 2.69 | 1.80 |
| | 2 x 1/2 | 3.19 | 2.40 |
| | 2 x 3/4 | 3.19 | 2.40 |
| | 2 x 1 | 3.19 | 2.50 |
| | 2 x 1 1/4 | 3.19 | 2.70 |
| | 2 x 1 1/2 | 3.19 | 2.70 |
| | 2 1/2 x 1 1/2 | 3.69 | 4.10 |
| 2 1/2 x 2 | 3.69 | 4.30 | |
| 3 x 2 | 4.06 | 5.80 | |
| 3 x 2 1/2 | 4.06 | 6.50 | |
| 4 x 3 | 4.38 | 10.00 | |

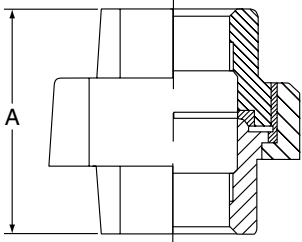
| UNIONS (BRASS SEAT) | Size | A | Weight |
|--|-----------|-----------|------------|
| | <i>in</i> | <i>in</i> | <i>lbs</i> |
|   | 1/4 | 1.81 | 0.47 |
| | 3/8 | 1.81 | 0.43 |
| | 1/2 | 2.06 | 0.53 |
| | 3/4 | 2.25 | 0.80 |
| | 1 | 2.56 | 1.30 |
| | 1 1/4 | 2.75 | 1.60 |
| | 1 1/2 | 3.00 | 2.10 |
| | 2 | 3.38 | 3.50 |
| | 2 1/2 | 3.88 | 5.00 |
| | 3 | 4.25 | 7.70 |
| | 4 | 4.88 | 18.00 |



Corporate Offices

110 Corporate Drive, Suite 10
P.O. Box 3180
Portsmouth, NH 03802-3180

Tel: 603-422-8000
Fax: 603-422-8033

E-mail: webmaster@anvilintl.com

Anvil International Worldwide Customer Service Center

Tel: 708-885-3000
Fax: 708-534-5441

U.S. REGIONAL SERVICE CENTERS

Northern Region

Regional Distribution & Customer Service Center

SERVICING: Illinois, Indiana, Iowa, Kentucky, Michigan, Minnesota, Nebraska, North and South Dakota, Ohio, West Pennsylvania, West Virginia, Wisconsin

750 Central Avenue
University Park, IL 60484

Tel: 708-885-3000
Fax: 708-534-5441
Toll Free: 1-800-301-2701

Southern Region

Regional Distribution & Customer Service Center

SERVICING: Alabama, Arkansas, Kansas, Louisiana, Mississippi, Missouri, Oklahoma, Tennessee, Texas

1401 Valley View Lane, Suite 150
Irving, TX 75061

Tel: 972-871-1206
Fax: 972-641-8946
Toll Free: 1-800-451-4414

Eastern Region

Regional Distribution Center

SERVICING: Connecticut, Delaware, Florida, Georgia, Maine, Maryland, Massachusetts, New Hampshire, New Jersey, New York, North and South Carolina, East Pennsylvania, Rhode Island, Vermont, Virginia

800 Malleable Road
Columbia, PA 17512

Western Region

Regional Distribution Center

SERVICING: Alaska, Arizona, California, Colorado, Hawaii, Idaho, Montana, Nevada, New Mexico, Oregon, Utah, Washington, Wyoming

1385 Greg Street
Sparks, NV 89431

CANADA SERVICE CENTER

Anvil International Canada Customer Service Center

390 Second Avenue
P.O. Box 40
Simcoe, Ontario N3Y 4K9

Tel: 519-426-4551
Fax: 519-426-5509

INTERNATIONAL SALES

Europe and Middle East Region

Rick van Meesen, *Sales Director*
The Netherlands
rvanmeesen@anvilintl.com

Tel: +31-53-5725570
Fax: +31-53-5725579

U.S. Customer Service
Tel: +1-708-885-3000
Fax: +1-708-534-5441

Mexico, Puerto Rico and Latin America

Abraham Quijada, *Sales Manager*
aquijada@anvilintl.com

Tel: +1-281-590-4600
U.S. Customer Service
Tel: +1-708-885-3000
Fax: +1-708-534-5441

BUILDING CONNECTIONS THAT LAST



www.anvilintl.com

#622/Printed in USA/RPI/© Copyright 2009
Revision Date: 9.4.09