

Fig. 194

Light Welded Steel Bracket

Material: Carbon steel

Finish: Plain or Galvanized

Service: Recommended for support from below or above bracket.

Approvals: Complies with Federal Specification A-A-1192A (Type 31), WW-H-171-E (Type 32), ANSI/MSS SP-69 and MSS SP-58 (Type 31). FM Approved when used with $\frac{3}{8}$ " rod, $\frac{3}{4}$ " - 4" pipe sizes & $\frac{1}{2}$ " rod, 5" - 8" pipe sizes.

How to size: Determine bracket size by dimension of standard bracket most suitable to the installation.

Installation: When bolted to a wall, an additional back plate may be required of such thickness and size as to properly distribute the weight over the wall. Size and thickness of the back plate is governed by the load to be carried and the nature and conditions of the wall. Back plates furnished upon request.

Features:

- Bracket may be installed either in position illustrated or reversed.
- Ends of bracket are drilled to accept hanger rods up to $\frac{3}{4}$ ".

Ordering: Specify bracket number, figure number, name and finish.

Order separately: Hanger rods, 2 bolts and plate washers are available through our Regional Service Centers, order as a Figure 193.

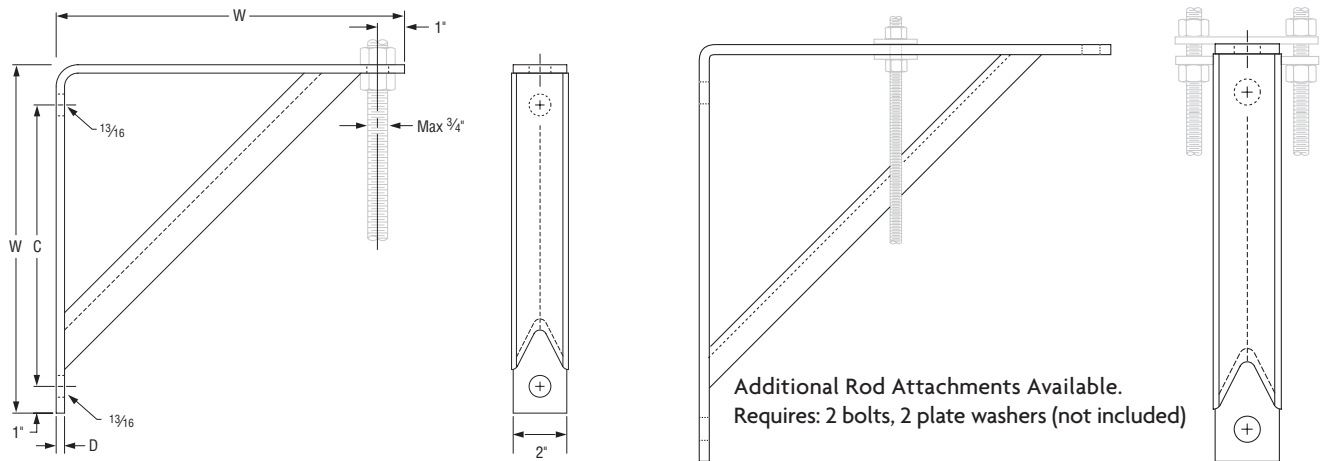

FIG. 194: LOAD (LBS) • WEIGHT (LBS) • DIMENSIONS (IN)

Bracket no.	Max Load	Weight	W	C	D
1	750	3.1	9	6½	5/16
2		7.7	13	10½	
3		12.8	19	16½	3/8

PROJECT INFORMATION		APPROVAL STAMP	
Project:		<input type="checkbox"/> Approved	
Address:		<input type="checkbox"/> Approved as noted	
Contractor:		<input type="checkbox"/> Not approved	
Engineer:		Remarks:	
Submittal Date:			
Notes 1:			
Notes 2:			