

GLOBE IB440 BRONZE

125 lb. SWP-200 lb. WOG† • Plumbing and Heating
Bronze Disc • Threaded Bonnet • Threaded Ends

1/4" to 1/2" sizes have the disc integral with the stem and have no disc ring.

SPECIFICATIONS

IB440	Conforms to: MSS SP-80, Type 1, Class 125, Threaded Ends.
-------	--

MATERIAL LIST

NO.	PART	MATERIAL	SPECIFICATION
1	Body	Bronze	ASTM B 62
2	Bonnet	Bronze	ASTM B 62
3	Disc	Bronze	ASTM B 62
4	Stem	Bronze	ASTM B 62
5	Disc Ring	Bronze	ASTM B 16 3/4" to 2" ASTM B 62 2 1/2" and 3"
6	Packing	Non-Asbestos	Commercial
7	Packing Nut	Brass	ASTM B 16
8	Handwheel	Mall. Iron	Commercial
9	Identification Plate	Aluminum	Commercial
10	Handwheel Nut	Brass	Commercial
11	Gland (not shown)	Brass	ASTM B 16 2 1/2" & 3" only

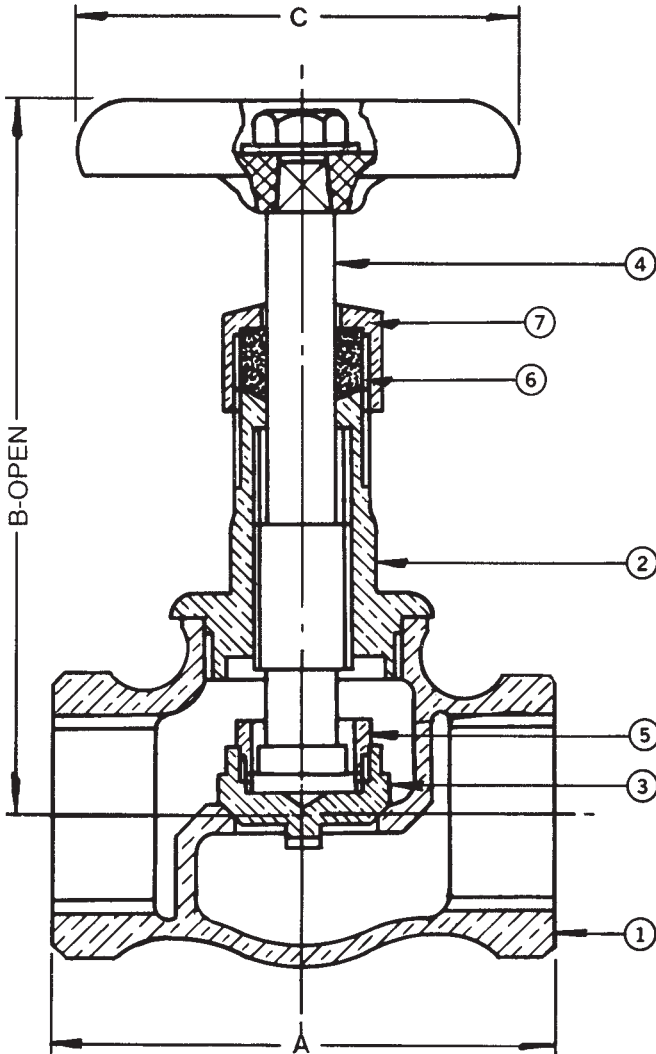

DIMENSIONS - INCHES / MILLIMETERS

Units	Size	A	B	C	C _v
Inches	1/8	1.63	3.06	2.00	0.61
mm	3.18	41.28	77.80	50.80	
Inches	1/4	1.63	3.06	2.00	1.16
mm	6.35	41.28	77.80	50.80	
Inches	3/8	1.81	3.19	2.00	2.21
mm	9.53	46.05	80.98	50.80	
Inches	1/2	2.31	3.63	2.25	3.64
mm	12.70	58.75	92.08	57.15	
Inches	3/4	2.56	3.94	2.50	6.65
mm	19.05	65.10	100.03	63.50	
Inches	1	2.94	4.38	2.75	11.10
mm	25.40	74.63	111.13	69.85	
Inches	1 1/4	3.38	5.19	3.13	20.00
mm	31.75	85.73	131.78	79.38	
Inches	1 1/2	3.69	5.75	3.50	28.00
mm	38.10	93.68	146.05	88.90	
Inches	2	4.44	6.75	4.00	48.00
mm	50.80	112.71	171.45	101.60	
Inches	2 1/2	5.75	8.63	4.75	70.00
mm	63.50	146.05	219.08	120.65	
Inches	3	6.88	9.25	5.50	111.00
mm	76.20	174.63	234.95	139.70	

† Non-Shock

Rev. 4

BETTER AT EVERY TURN



HAMMONDVALVE
www.hammondvalve.com

The information presented on this sheet is correct at the time of publication. Hammond Valve reserves the right to change design, and/or material specifications without notice. For the Installation, Operation and Maintenance Manual (IOM) see the engineering section on our website. For the most current information access www.hammondvalve.com